

REPORT

# Geothermal lessons from Germany, Denmark and France for the Dutch Market

PREPARED BY  
European Geothermal Energy Council  
<https://www.egec.org/>  
Well Engineering Partners  
[www.wellengineeringpartners.com](http://www.wellengineeringpartners.com)

PREPARED FOR  
Invest-NL <https://www.invest-nl.nl/>



**INVESTNL**

## DISCLAIMER

*This research report is intended for informational purposes only. Although the report has been prepared with the utmost care and accuracy, the use of the information in this report is at your own risk. We do not accept any liability for any damages, losses, or other inconveniences that may arise from the use of this information.*

*All intellectual property rights related to this research report belong to us or our licensors. When distributing or using (parts of) the report, we kindly ask you to always include the attached links [www.invest-nl.nl](http://www.invest-nl.nl), [www.egec.org](http://www.egec.org) or [www.wellengineeringpartners.com](http://www.wellengineeringpartners.com) and mention the original document. It is not permitted to modify this report without our express prior written consent. For questions or more information about the report, please contact Invest-NL ([info@invest-nl.nl](mailto:info@invest-nl.nl)).*

## CONTENTS

<b>1</b>	<b>SUMMARY / ABSTRACT</b>	<b>7</b>
<b>2</b>	<b>INTRODUCTION &amp; SCOPE OF WORK</b>	<b>9</b>
<b>3</b>	<b>APPROACH &amp; REPORT CONTENT</b>	<b>11</b>
3.1	BENCHMARK CASES AND DEFINITION	11
3.2	INTERNATIONAL STAKE HOLDER INTERVIEWS & DATA COLLECTION	11
3.3	LEARNINGS & SOLUTIONS	11
3.4	DISCUSSION & CONCLUSION	11
<b>4</b>	<b>SUMMARY – BENCHMARK CASES &amp; LEARNINGS</b>	<b>12</b>
4.1	GENERAL	12
4.1.1	<i>Financial aspects</i>	17
4.1.2	<i>Risk management &amp; insurance</i>	21
4.2	GERMANY	25
4.2.1	<i>General</i>	27
4.2.2	<i>Financial instruments</i>	30
4.2.3	<i>Governance</i>	32
4.2.4	<i>Social acceptance</i>	36
4.2.5	<i>Permitting</i>	40
4.2.6	<i>Legislation</i>	42
4.2.7	<i>Technology</i>	44
4.2.8	<i>Hurdles / threats</i>	44
4.2.9	<i>Specific recommendations/options</i>	44
4.2.10	<i>Key lessons learnt from Germany to replicate in the Netherlands</i>	54
4.3	DENMARK	57
4.3.1	<i>General / Current status</i>	57
4.3.2	<i>Financial instruments / financing the green transition</i>	62
4.3.3	<i>Governance</i>	63
4.3.4	<i>Social acceptance</i>	65
4.3.5	<i>Permitting</i>	67
4.3.6	<i>Legislation</i>	68
4.3.7	<i>Market trend</i>	69
4.3.8	<i>Technology</i>	70
4.3.9	<i>Key lessons learnt from Denmark to replicate in the Netherlands</i>	75
4.4	FRANCE	77
4.4.1	<i>General</i>	77
4.4.2	<i>Financial instruments</i>	78
4.4.3	<i>Governance</i>	84
4.4.4	<i>Social acceptance</i>	85
4.4.5	<i>Regulations</i>	85

4.4.6	Legislation .....	87
4.4.7	Technology – Case studies.....	89
4.4.8	Key lessons learnt from France to replicate in the Netherlands .....	91
4.5	EUROPEAN UNION .....	92
4.5.1	Priorities for investments.....	92
4.5.2	Key lessons learnt from EU side to be implemented in the Netherlands.....	93
<b>5</b>	<b>NETHERLANDS – SNAPSHOT OF TODAY'S STATUS .....</b>	<b>96</b>
5.1	CURRENT STATUS.....	96
5.2	EBN .....	96
5.2.1	Socio-economic benefits .....	97
5.3	FINANCIAL INSTRUMENTS .....	98
5.3.1	Government Incentives .....	99
5.3.2	Insurance.....	99
5.4	GOVERNANCE .....	100
5.4.1	Key Regulations Governing Geothermal Projects .....	100
5.4.2	Regional Involvement.....	101
5.4.3	Financial Incentives and Public Participation.....	101
5.5	SOCIAL ACCEPTANCE .....	102
5.5.1	Positive aspects of geothermal projects: .....	102
5.5.2	Negative aspects of geothermal projects:.....	102
5.5.3	Public opinion.....	102
5.5.4	Conditions for social acceptance: .....	102
5.6	PERMITTING .....	102
5.6.2	Pre-application phase .....	103
5.6.3	Application phase.....	103
5.6.4	Decision phase.....	103
5.6.5	Implementation phase.....	103
5.6.6	Operational phase:.....	103
5.6.7	Termination or modification phase.....	103
5.7	LEGISLATION .....	104
5.7.1	Key Legislation.....	104
5.7.2	Permits and Approvals .....	104
5.7.3	Environmental Protection Measures.....	104
5.8	TECHNOLOGY.....	105
5.9	HURDLES .....	105
5.9.1	Geological and Technical Challenges.....	105
5.9.2	Regulatory Hurdles.....	106
5.9.3	Financial and Economic Challenges.....	106
5.9.4	Fragmented Governance .....	107
5.9.5	Environmental Concerns.....	107



5.9.6	<i>Infrastructure and Market Development</i> .....	108
5.9.7	<i>Public Awareness and Acceptance</i> .....	108
5.9.8	<i>Land Use Conflicts</i> .....	109
5.9.9	<i>Visual Impacts</i> .....	109
5.9.10	<i>Competition with Other Energy Sources</i> .....	109
5.9.11	<i>Long-term Sustainability and Monitoring</i> .....	109
<b>6</b>	<b>KEY LESSONS LEARNT FROM ABROAD</b> .....	<b>110</b>
6.1	EUROPEAN UNION .....	110
6.1.1	<i>Politics</i> .....	110
6.1.2	<i>Market &amp; Economy</i> .....	110
6.1.3	<i>Innovation &amp; Technologies</i> .....	110
6.1.4	<i>Transfer, Capacity &amp; Acceptance</i> .....	111
6.2	GERMANY .....	111
6.2.1	<i>Politics</i> .....	111
6.2.2	<i>Market &amp; Economy</i> .....	113
6.2.3	<i>Innovation &amp; Technologies</i> .....	113
6.2.4	<i>Transfer, Capacity &amp; Acceptance</i> .....	113
6.3	DENMARK .....	114
6.3.1	<i>Politics</i> .....	114
6.3.2	<i>Market &amp; Economy</i> .....	114
6.3.3	<i>Innovation &amp; Technologies</i> .....	115
6.3.4	<i>Transfer, Capacity &amp; Acceptance</i> .....	115
6.4	FRANCE .....	116
6.4.1	<i>Politics</i> .....	116
6.4.2	<i>Market &amp; Economy</i> .....	116
6.4.3	<i>Innovation &amp; Technologies</i> .....	117
6.4.4	<i>Transfer, Capacity &amp; Acceptance</i> .....	117
<b>7</b>	<b>FINAL RECOMMENDATIONS FOR NL</b> .....	<b>118</b>
7.1	POLICY .....	118
7.2	REGULATIONS .....	119
7.3	MARKET & ECONOMY / FINANCING .....	119
7.4	TECHNOLOGY DEVELOPMENT .....	120
7.5	VISIBILITY.....	121
7.6	HEAT NETS / DISTRICT HEATING .....	122
7.7	INTERNATIONAL COOPERATION.....	122
<b>8</b>	<b>LIST OF FIGURES</b> .....	<b>123</b>
<b>9</b>	<b>LIST OF TABLES</b> .....	<b>125</b>
<b>10</b>	<b>REFERENCES</b> .....	<b>126</b>
<b>11</b>	<b>APPENDICES</b> .....	<b>130</b>
11.1	APPENDIX 1: LESSONS LEARNED .....	130

11.2	APPENDIX 2: ANSWERING QUESTIONS .....	132
11.2.1	<i>What guarantees and certainties are needed to attract investors for large-scale geothermal projects in the Netherlands?</i> .....	132
11.2.2	<i>How can we promote cooperation between government, industry, and financial institutions to stimulate geothermal energy on a large scale?</i> .....	135
11.2.3	<i>What impact do different scales (local, regional, national) have on the financing and cost reduction of geothermal projects, and how should strategies be adapted accordingly?</i> .....	138
11.2.4	<i>How can licence applications to central and local authorities be accelerated?</i> .....	144
11.2.5	<i>How can the knowledge of geothermal energy among central and local authorities be increased?</i> .....	147
11.2.6	<i>How can geothermal investments be insured through the government?</i> .....	150
11.2.7	<i>Which restrictive general government regulations have a negative effect on the speed at which geothermal energy can be developed?</i> .....	151
11.2.8	<i>How can delaying objections to geothermal energy be mitigated?</i> .....	154
11.2.9	<i>Are the relevant subsidies still appropriate and sufficient?</i> .....	156
11.3	APPENDIX 3: FINANCIAL MODELS FOR THE FUTURE .....	158
11.3.1	<i>Increased focus on long-term project value</i> .....	158
11.3.2	<i>Venture Capital and Private Equity</i> .....	158
11.3.3	<i>Development of risk-adjusted metrics</i> .....	158
11.3.4	<i>Machine Learning Models &amp; AI-Powered Optimization Models</i> .....	158
11.3.5	<i>Integrated Financial and Technical Models</i> .....	158
11.3.6	<i>Scenario Analysis Models</i> .....	158
11.3.7	<i>Adopt Real Options Models / Analysis</i> .....	158
11.3.8	<i>Pension Funds / life insurers</i> .....	159
11.3.9	<i>Sustainable Finance Models</i> .....	159
11.3.10	<i>Decentralized Finance (DeFi)</i> .....	160
11.3.11	<i>Energy Performance-based Contracts</i> .....	160
11.3.12	<i>Government and utility incentives &amp; guaranties</i> .....	160
11.3.13	<i>Investment by / participation of O&amp;G companies</i> .....	161
11.3.14	<i>Crowdfunding and Community Funding / participation of citizens</i> .....	161
11.3.15	<i>International Development Funding</i> .....	161
11.3.16	<i>Energy-as-a-Service (EaaS)</i> .....	161
11.3.17	<i>Integration with other Renewable Sources at the same site (Renewable Energy park)</i> 161	
11.3.18	<i>Reverse auction</i> .....	161
11.3.19	<i>Leasing of geothermal sites</i> .....	162
11.3.20	<i>Summary</i> .....	162

## 1 SUMMARY / ABSTRACT

Geothermal energy has the potential to play a major role in the energy transition regarding heating, cooling and electricity generation. Direct heating applications get the focus in the Netherlands because of the lower temperature gradient compared to some other countries that use geothermal power.



The Dutch geothermal temperature range of 70-95°C is sufficient high to directly heat most houses with reasonable isolation. The heat transition, and therefore also the energy transition, can be accelerated by ramping up geothermal energy to ensure a widespread supply of renewable heating energy to the population, the industry, and the agriculture. The key question is, what can to be done to accelerate this process?

Accelerating geothermal energy projects in the Netherlands requires careful consideration of key success factors across various aspects. These factors, include long term political support, collaboration, regulatory frameworks, permitting processes, policy support, market conditions, financial models, risk mitigation measures, insurances, innovation, capacity building, social acceptance, and stakeholder engagement.

Although geothermal energy is competitive with other sustainable energy sources at end-user level, the geothermal system itself is far less attractive for investors compared to oil and gas. Hence, the investment case needs support from early-risk mitigation incentives, long term heat contracts, taxation/subsidies/development funds and reduced life-cycle-costs as technologies and efficiencies develop.

At the same time, initial investments are expected to drop by typically 20% due to economics of scale, innovations, and improved efficiency while visibility is increased and can act as flywheel. Areas with large impact should be prioritized.

The most effective way to accelerate the use of geothermal heat is to promote large scale projects because the lead times due to permitting and purchasing will remain the same for more heat generated.

Apart from geothermal wells, the roll out of heating networks is a must to generate a market for the sustainable heat producers, not only geothermal energy suppliers. The Danish setup is good example of transparent pricing and good performance.

They proof to be a viable solution to deliver reliable and cost-effective heat on peak demands in Danish winters. In the Netherlands, the peak demand capacity relies on natural gas supply only.



Geothermal project time scales in the Netherlands are driven by licensing and SDE++ and will need to extend to at least 30 years in line with long term heat net contracts. The longer periods will de-stress the business cases and attract investors looking for long term stability such as pension funds.

Collaboration, knowledge sharing, and the establishment of strategic alliances are encouraged for effective geothermal and urban development planning.

The importance of political leadership at both the EU and national levels by building and maintaining roadmaps is emphasized. This includes the promotion of geothermal energy through climate and energy legislations, stable and balanced energy policy frameworks, and making use of EU financial programs for risk mitigation and project financing. Non-pricing elements need to be part of the discussions.

Collaboration between government, local authorities, industry, and financial institutions is also crucial for successful project implementation.

Regular stakeholder forums, clear roles and responsibilities, national and local roadmaps specific for heat and monitoring progress through regular and continuous dialogue are recommended.

Streamlining and harmonizing permitting processes is another key recommendation. This can be achieved by collaborating to reduce administrative burdens, establishing clear guidelines and fixed timeframes to avoid uncertainty and delays. Risks to the people and environment should be leading.

Governmental leadership plays a vital role in advancing the geothermal industry. It brings visibility and security for investment with a stable frame and ambitious targets.

This includes providing support for research and development initiatives, facilitating collaborative research, motivating oil & gas and electricity companies to participate, and establishing a national geothermal energy platform.

Additionally, creating attractive market conditions and financial incentives is crucial for the success of large-scale geothermal projects. This can be achieved through auctions with non-price criteria, financial assistance, and risk mitigation measures that make projects financially appealing to investors and end-users.

Various financial models, incentives, and funding schemes are suggested to make geothermal projects more financially attractive to a leverage of private finance. Close collaboration with financial institutions is recommended to design incentive structures that benefit both investors and end-users. Financial risk mitigation schemes, risk insurance, and feasibility studies, are emphasized to de-risk projects and provide the necessary support especially in green fields.

Innovation and technology play a significant role in accelerating geothermal projects. Scaling project sizes, developing key technologies, and demonstrating flagship projects are recommended

## 2 INTRODUCTION & SCOPE OF WORK

Geothermal Energy is a clean energy that can play an important role in the ongoing energy transition. Currently in the Netherlands, 33% of total gas use is used for heating of houses where geothermal energy can be a direct replacement. The technique has proven itself in some places and applications in the Netherlands, e.g.

greenhouse direct heating applications, and abroad while it struggles to deliver its promises in other locations. The success of geothermal energy for greenhouses comes from the combination of large & continuous heat demand, relative few stakeholders involved, entrepreneurial attitudes and no need for an (external) heat network.

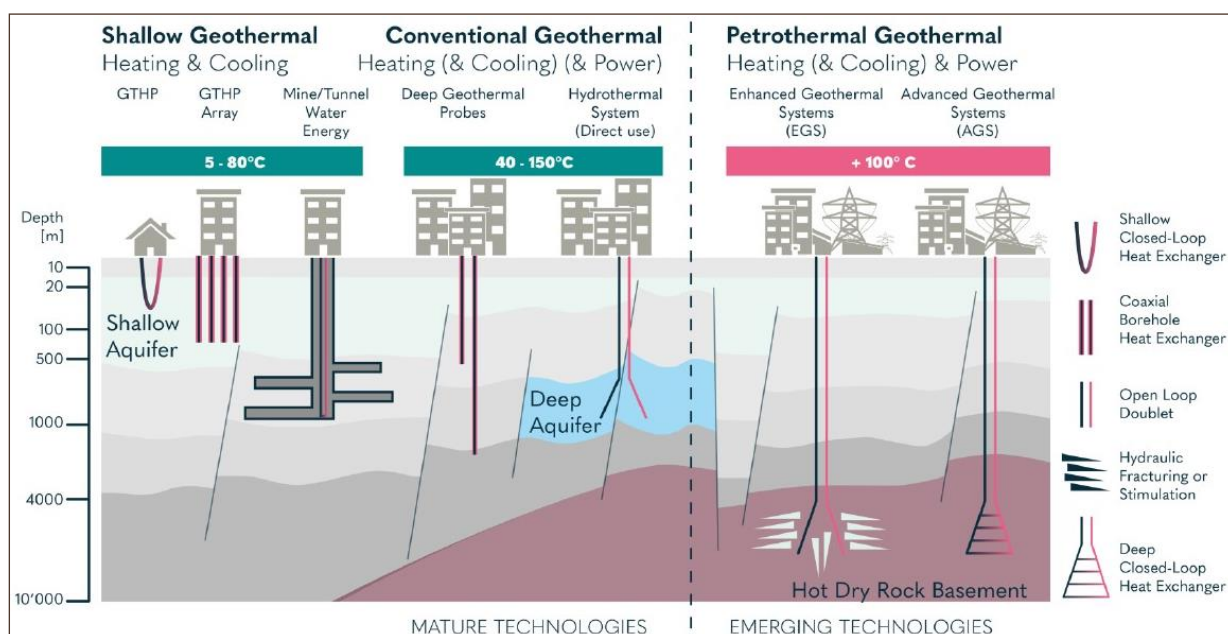

Figure 1: Geothermal systems archetypes. Illustration taken from (EAPOSYS, 2023) adapted from (Abesser, 2020) BGS.

Invest-NL wants to understand what bottlenecks exist and what opportunities exist for Invest-NL to accelerate the use of Geothermal Energy in the Netherlands. In the Netherlands, hydrothermal systems for Direct Use of heat currently prevail. The focus should be on financial instruments, governance, social acceptance, permitting,

and legislation opposed to technical issues, although it may not be possible to discard them completely. To prevent from re-inventing the wheel, WEP was asked to study what could be learned from foreign projects and look at market conditions in other European countries.



---

The scope should focus on answering the **following questions**:

1. What are the experiences of other countries with large-scale geothermal projects and what lessons can we draw from this for the Netherlands?
2. What guarantees and certainties are needed to attract investors for large-scale geothermal projects in the Netherlands?
3. How can we promote cooperation between government, industry, and financial institutions to stimulate geothermal energy on a large scale?
4. What impact do different scales (local, regional, national) have on the financing and cost reduction of geothermal projects, and how should strategies be adapted accordingly?
5. How can licence applications to central and local authorities be accelerated?
6. How can the knowledge of geothermal energy among central and local authorities be increased?
7. How can geothermal investments be insured through the government?
8. Which restrictive general government regulations have a negative effect on the speed at which geothermal energy can be developed?
9. How can delaying objections to geothermal energy be mitigated?
10. Are the relevant subsidies still appropriate and sufficient?

WEP and the co-writers analysed geothermal projects outside the Netherlands and checked what can be learned (positive or negative) to accelerate geothermal energy in the Netherlands, with particular interest in energy supply to residential areas. The research focuses on financial, governance, legal and social

aspects and is built on case studies, treatment of already published reports, stakeholder interviews and other info collection. Target areas are Denmark, Germany, and France. This report will focus on hydrothermal system for Direct Use of heat.

### 3 APPROACH & REPORT CONTENT

#### 3.1 Benchmark cases and definition

Several case studies will be used to collect the learnings of the different possible project realizations. The studies will be performed using public information, knowledge from the core team members and using the teams contacts. Targeted countries of interest but not limited to, are:

- a. Denmark
- b. Germany
- c. France
- d. European Union

The report covers only large-scale geothermal technologies with focus on

direct heat applications. Nevertheless, it includes remarks on geothermal electricity plants, combined heat and power plants and Geothermal district heating or district cooling.

'Geothermal district heating or district cooling' is defined as the use of one or more geothermal production fields as sources of heat/cold to supply thermal energy through a network to multiple buildings or sites. It includes greenhouses and geothermal heat projects above 500 kWth supported by heat pumps if the heat is distributed via a pipe network to more than one building or site.

#### 3.2 International stake holder interviews & data collection

Generic information, opinions and potential improvement solutions will be collected by questioning relevant stakeholders in the targeted countries. The findings from the case studies and the answers on ten above

listed questions will be used in the discussions. The data collection covers also existing publications about geothermal in the countries covered.

#### 3.3 Learnings & solutions

All observed key lessons learnt from abroad and recommendations will be listed and briefly discussed.

#### 3.4 Discussion & conclusion

The study will conclude by answering the above-listed questions based on the findings, discussion and suggested solutions and opportunities.

## 4 SUMMARY – BENCHMARK CASES & LEARNINGS

### 4.1 General

The European geothermal sector is very dynamic and diverse, and all European countries face the challenges to develop more geothermal projects to move from a niche market to a larger market with exponential growth. Due to the different geology across Europe, the use of geothermal energy and the local experience and exposure to drilling operations differs, resulting in different business cases, legislation, and public opinion.

The EU recently proposed a Net Zero Industry Act (NZIA) and gives specific attention to geothermal as one of the eight strategic net zero technologies.

The EU’s Commissioner for Energy, Kadri Simson, has called on Europe to “harness geothermal energy’s potential. For too long the benefits of this sector have not been well understood – now is the time to learn.” (2022)

National geothermal roadmaps recently published in Poland, Germany and France

are good signals. This must be replicated by all European countries, cities and/or regions to plan geothermal development.

IEA (December 2002) and ADEME (edition 2022) show that geothermal heating technologies are the more competitive sources. According to IEA globally T\$3 – T\$6 (B\$3,000 from private sector) investment per year is required until 2050, more than new fossil investments, to meet the Paris climate goals. In 2023 the investment was only B\$1,300 globally. Investments are increasing supported by American Inflation Reduction Act & European Green Deal Plan. For the EU B\$660 per annum is targeted.

A significant milestone for geothermal electricity generation, 2023 marks the 110th anniversary of the first-ever geothermal power plant in Larderello, Italy. The oldest geothermal power plant is still in operation is from 1986.

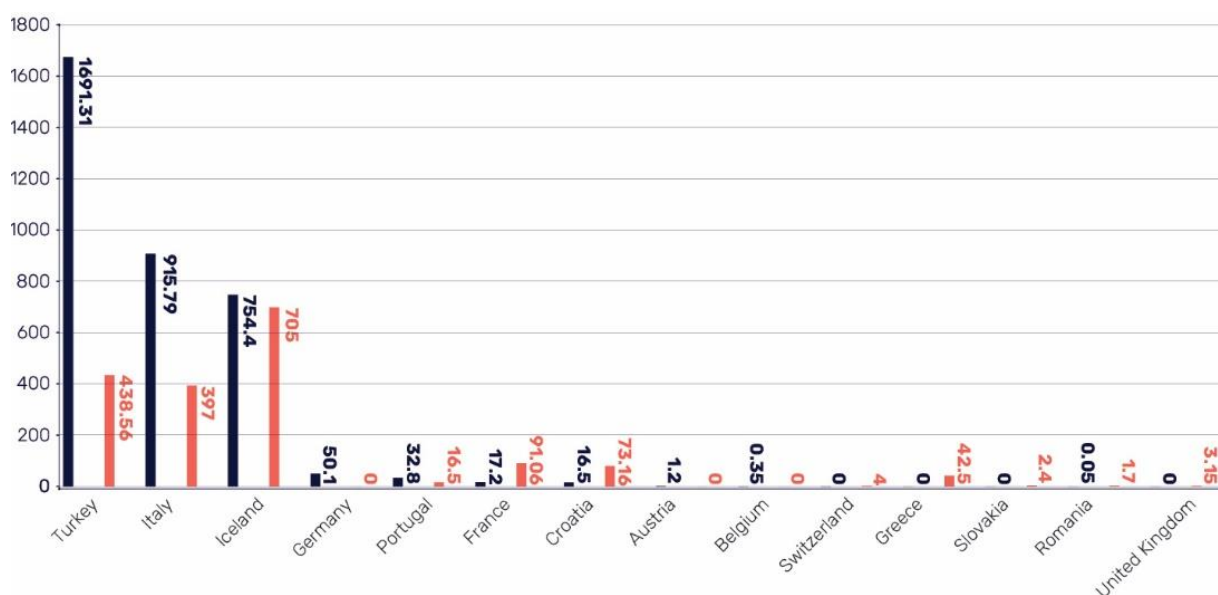

Figure 2: Installed capacity and capacity under development for electricity in 2022 (MW)

In 2022, 142 geothermal power plants are in operation with an installed capacity of about



3,5 GWe and generating more than 22 TWh. The average capacity factor last year was 79%, the highest of all electricity sources, except nuclear. The development of geothermal electricity in Turkey, Italy, Iceland Germany and France has established a workforce able to develop geothermal heat projects, but also a

regulatory frame for all deep geothermal technologies.

Continued growth in geothermal district heating and cooling systems: In 2022, the expansion of geothermal district heating and cooling systems persisted. By the year's end, there were 395 operational systems - an increase of 14 compared to 2021. There are more than 300 projects

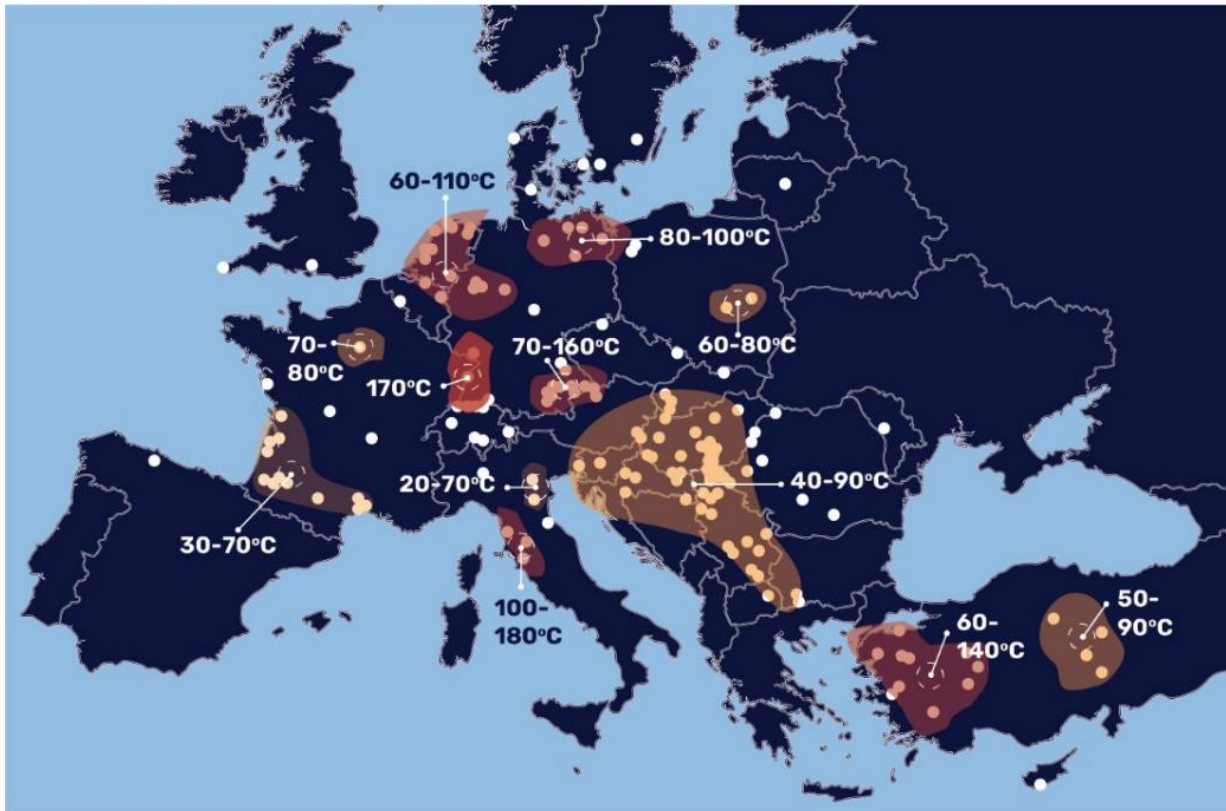

under development.

Figure 3: Mapping of main geothermal district heating and cooling reservoirs with existing systems and temperature.

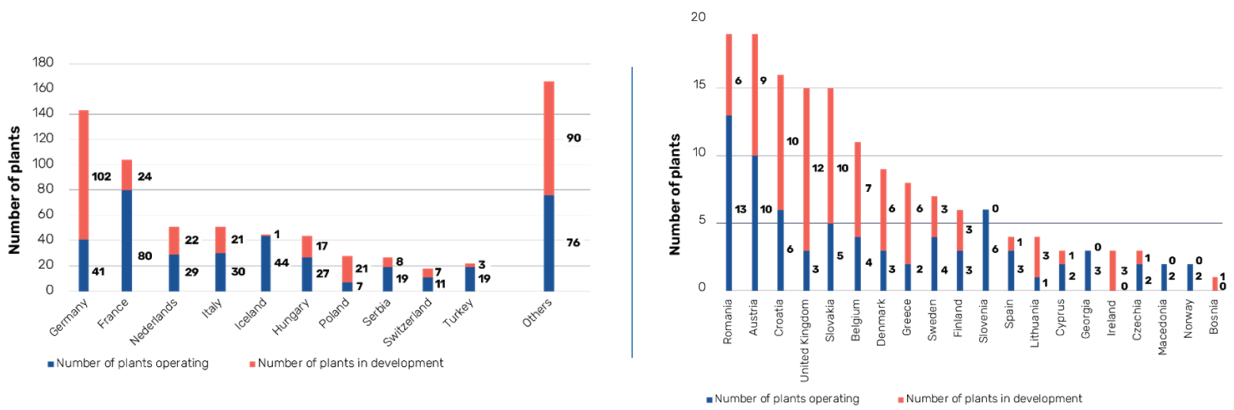

Figure 4: Number of geothermal district heating and cooling, operating and in development (largest and emerging European markets)

All over Europe, we expect more than 30 wells to be drilled in the next 3 to 5 years for geothermal electricity power plants. More than 100 wells will be drilled for heating projects over the coming years.

The key barriers include the project financing to cover high capital investment and the coverage of the resources risk, the market conditions, and the permitting process. Socio-economic aspects may be a barrier in some regions regarding public acceptance. In the last years, availability of materials, equipment and skilled people have resulted in delays of projects.

To improve business cases, cascading systems are being used and alternative resources as Lithium are mined. Note that

(heat) cascading systems have a larger difference between production and injection temperature which is limited in The Netherlands, i.e. for differential temperatures over 40°C a penalty is applied to the maximum allowable injection pressure what limits the cascading potential.

Higher temperatures will offer more potential applications however, easily reachable maximum temperatures are lower in the Netherlands compared to other countries in Europe. The potential of deeper formations in the Netherlands with higher temperatures, such as Dinantien, are being investigated.

**All over Europe, we expect more than 30 wells to be drilled in the next 3 to 5 years for geothermal electricity power plants. More than 100 wells will be drilled for heating projects over the coming years.**

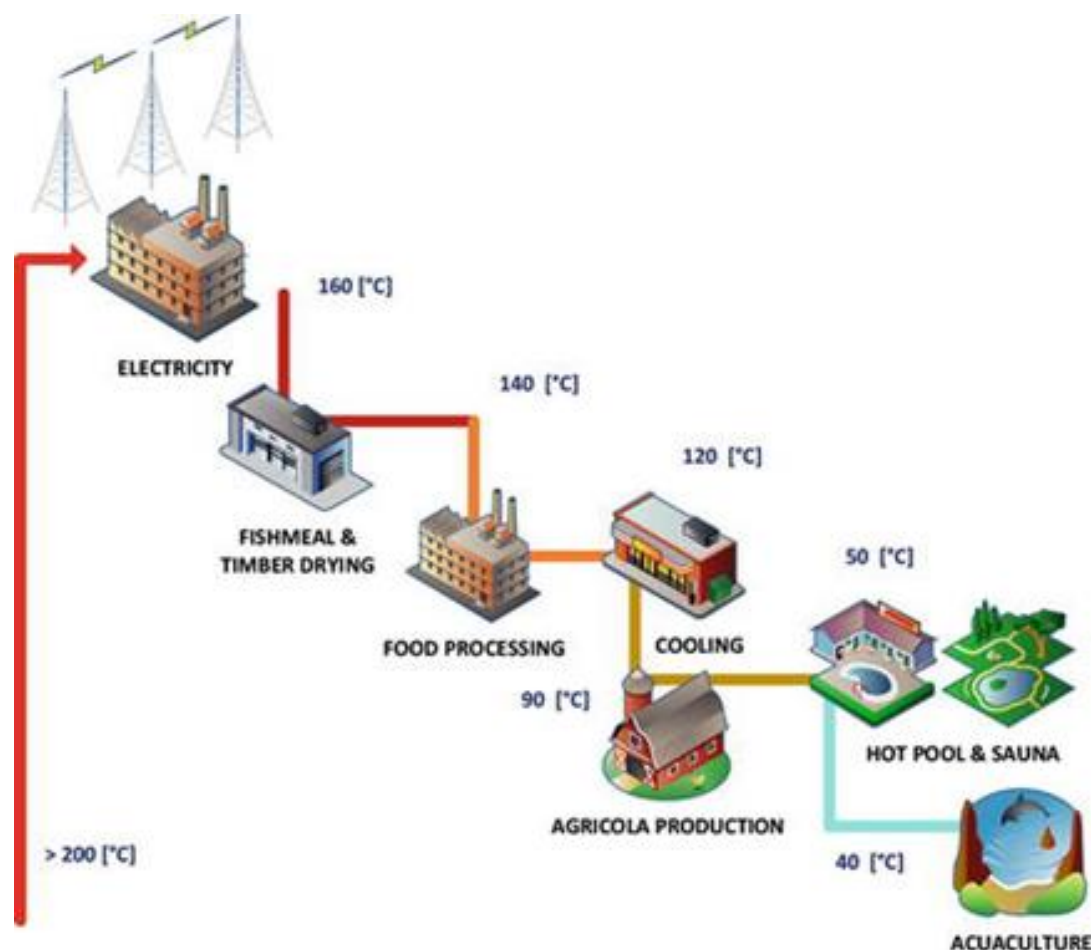
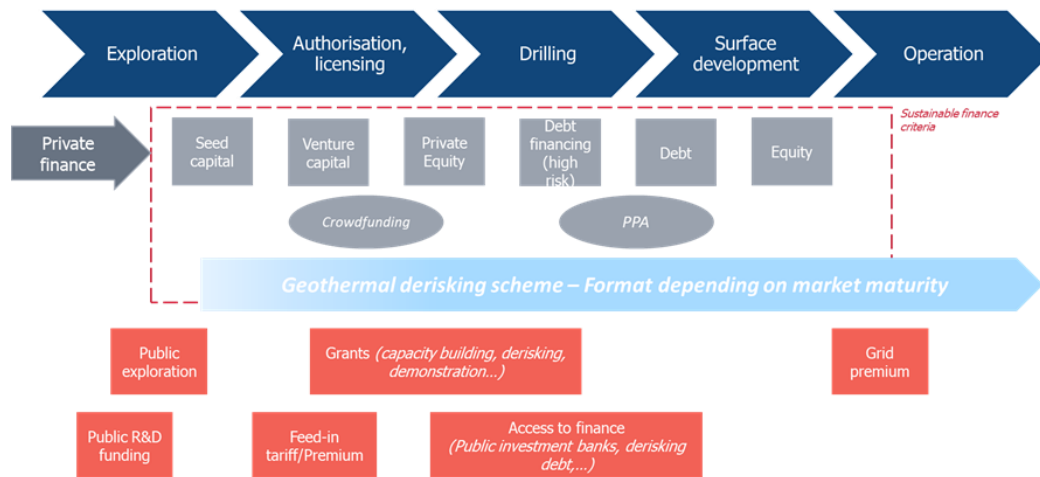

Figure 5: Cascading of geothermal heat. Starting from electricity using the highest temperature down to fish farms using the lowest temperatures (Héctor Aviña-Jiménez, 2022)

The European markets are diverse and apply as well for the financial instruments available as shown for example in “an overview of the available instruments” by (Philippe Dumas, 2017), Figure 6. Main challenge for financing geothermal energy projects is “the cost structure that requires large upfront investments while the viability of the project is unknown due to uncertainties on the quality of the resource before the well is drilled. Moreover, geothermal projects are often undertaken by small and medium-sized enterprises or

local public authorities, which have more limited finances or less capacity to take on debt”. Mostly regulatory barriers and the totally inhomogeneous regulatory framework across European countries hinder the step into the decision for a financial investment in the development of geothermal projects. How different this looks like in the benchmark countries Denmark, Germany and France, which have been chosen for this paper as contrast to the existing situation within the Netherlands will be shown within this paper.



**Figure 6: Mechanisms for funding geothermal energy projects at different stages of projects development (elaborated by EGEC, updates 2023) (Philippe Dumas, 2017)**

“The right scheme for the right market maturity.” This could be the maxim for financing geothermal energy projects as the geothermal sector is far from being uniform in terms of maturity and technology readiness across geographical, technology lines and uses.

As **Figure 7** below illustrates, to incentivize the scalability of geothermal technologies the exposure to market conditions should

not anticipate their market maturity, but rather accompany the technologies towards this goal.

Suitable support schemes and financial instruments allow for the cost reductions necessary for a technology to reach the market and for the consolidation of an emerging renewable industry in a market that remains very favourable to incumbent fossil technologies

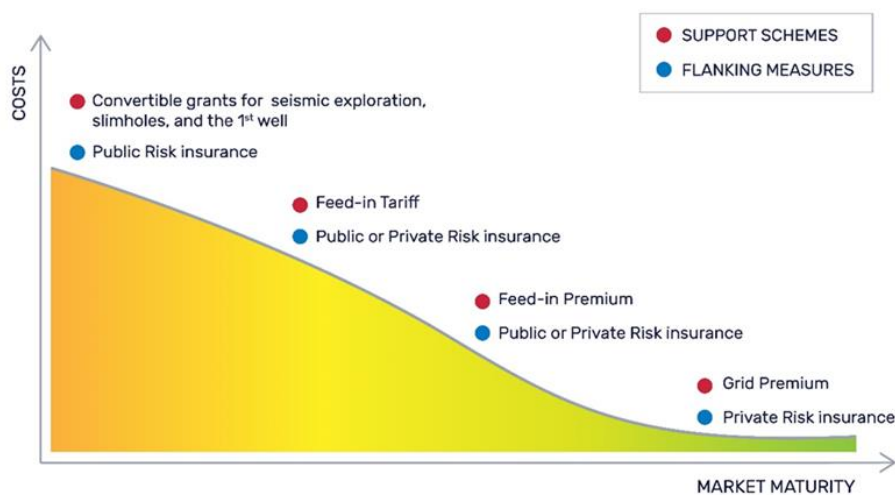

**Figure 7: Support schemes for Geothermal adapted to technology maturity (EGEC, 2024)**

## 4.1.1 Financial aspects

### 4.1.1.1 Private financing - Role of banks, financial institutions, and pension funds

In the geothermal sector, banks and financial institutions are usually risk adverse, so they contribute to project funding once risks are controlled. It means There are several categories of actors that provide private financing to geothermal energy projects, each with their own specific characteristics. However, private investors are looking to balance the risk and profitability of their investments, usually reflected in a metric such as the cost of

usually after the confirmation drilling of the second well in a doublet system.

Pension funds adopt the same position.

capital. Different types of investors will have a different tolerance to risk: for instance, a large financial institution with a diversified project portfolio may be more willing to invest in a riskier geothermal project than a small investor that would entirely rely on said project.

**Table 1: Types of private investors and projects supported**

Category of private investor	Type of geothermal projects supported	Type of financing provided
<b>Local banks</b>	Geothermal heat pumps (individual, large buildings, business...), district heating...	Loans
<b>Private equity</b>	Geothermal developers, manufacturers, large projects (district heating, electricity)	Equity financing
<b>Pension funds</b>	All	Any, through private financial institutions such as banks or PE
<b>Investment banks</b>	Refinancing, manufacturers, utilities, large scale project financing	Loans, equity, complex financial products
<b>Households</b>	Geothermal heat pumps, district heating	Private investment, heat bills payment
<b>SMEs</b>	Geothermal heat pumps, district heating/heat for processes, small electricity projects	Private investment (equity), corporate PPA
<b>Utilities</b>	All (typically larger projects)	Private investments, project finance (typically structured by involving other investors)
<b>Citizens/energy communities</b>	All, usually projects within the community	Crowdfunding (loans, grant, equity...)



---

In the current financial market, very few actors have been willing to finance the first phase of a geothermal project development. Baseload capital is a newcomer and a unique investor in the exploration phase for geothermal. Baseload Capital is a specialized investment entity that leads partnerships to scale up geothermal power deployment worldwide, by offering early-stage capital, equity and/or debt.



Until now, Pension funds have not been very active in the geothermal market, although it should be considered as a long-term investment. We can mention the case of the sale of the majority stake in Icelandic energy company HS Orka h with Icelandic pension funds in cooperation with a British investment fund buying Innergex' share for USD 300m; and Danish pension company Sampension investing in Innargi.

Various instruments allow geothermal project developers to gather the necessary capital for their geothermal project. Instruments can be deployed at various scale: there are for instance significant differences in the loan provided to a household for installing a geothermal heat pump in their home by a local bank, and the loan provided by an investment bank to a utility for the financing of several large-scale geothermal projects in export markets. The financial instruments usually provided by private financial actors to geothermal projects include:

**Loans:** the provision of a sum of money that must be paid back to the investors (at an interest). Loans are an attractive option for developers in the current financial conditions of low interest rates. However,

they require a robust derisking framework and a degree of maturity in the geothermal energy market as investors want to minimise their risks.

**Equity:** in providing equity, private investors become directly involved in the projects, and do not receive a return if the project is not profitable enough. As a riskier form of financing, it is usually provided either directly by developers, or at later stages of the project where the geothermal risk has been mitigated to a large extent.

Corporate PPAs are an emerging financing instrument for geothermal project developers. By securing the demand for the geothermal energy produced, developers ensure their income, which in turns reduces the financial risk profile of the project. Corporate PPAs are emerging rapidly as the evolution of public operational support framework is exposing developers to more financial risks.

There is no single private financial instrument that is inherently better for geothermal energy technologies. Moreover, beyond direct financing, some financial instruments can be directly relevant to the market uptake of geothermal energy projects.



For instance, securities backed on the provision of geothermal energy, harmonized within the framework of the EU sustainable finance taxonomy, can allow to direct new financing to the geothermal sector. However, such complex financial products are only emerging in the renewable sectors and need a harmonized set of standards to prevent greenwashing.

---

#### 4.1.1.2 Taxonomy – environmental LCA and GHG emissions

The sustainable finance framework aims to direct private and public financial flows towards companies, technologies and projects that are consistent with the long-term objective of a decarbonized economy.

The framework is structured around a major concern of standardization and preventing greenwashing, notably in light of the rapidly increasing number of “green” financial products. Overall, the Sustainable Finance

The Taxonomy, and the Sustainable Finance Regulation from which it derives, are only parts of the sustainable framework, however. They are central components, but the robustness of the Taxonomy is for instance legitimized in principle by the Platform on sustainable finance, a group of experts who work to ensure the alignment of the sustainable finance criteria and their implementation are consistent with the environmental objectives at the core of the sustainable finance framework. Moreover, the success of the Sustainable Finance is

framework seeks to identify a list of sustainable investments, increase the amount of money being channeled to such investments, and ensuring that these financial flows are robust both from an environmental and financial perspective. At the heart of the Sustainable Finance framework is the European Taxonomy for Sustainable Investments which discriminates between investments that are sustainable and those that are not.

very much reliant on the extent to which it is taken up by financial stakeholders as a relevant indicator of the “sustainability” of an investment portfolio or a financial product.

Geothermal energy technologies are clearly identified as sustainable investments in the sustainable finance taxonomy. Geothermal power plants, geothermal district heating and cooling, geothermal cogeneration, geothermal heat pumps, ATES, UTES and other forms of thermal energy storage can all be eligible as a “sustainable investment”.

#### 4.1.1.3 Basis for financial analyses

In general, a geothermal project is based on a number of financial analyses, including:

- **Project feasibility study:** This study assesses the technical and economic feasibility of the project. It includes a detailed analysis of the resource potential, the cost of development, the revenue stream, and the risk profile.
- **Financial model:** This model calculates the project's net present value (NPV), internal rate of return (IRR), and payback period. It also considers the impact of different scenarios, such as changes in the price of electricity or the cost of drilling.

- **Debt financing:** This analysis determines the amount of debt that can be secured for the project. It considers the creditworthiness of the developer, the project's collateral, and the interest rate environment.
- **Equity financing:** This analysis determines the amount of equity that needs to be raised for the project. It considers the valuation of the project, the appetite for risk among potential investors, and the terms of the equity financing.
- **Project insurance:** This analysis assesses the risks associated with the project and the need for insurance coverage. It includes coverage for drilling risks, equipment failures, and environmental liabilities.

Additional factors that are often considered in the financial analysis of a geothermal project:

- **Size and quality of the geothermal resource:** The larger and more reliable the resource, the more attractive the project will be to investors.
- **Depth of the geothermal resource:** Deeper resources can be more expensive to develop, but they can also yield more heat / power.

#### 4.1.1.4 Currently used financial models

Geothermal projects are typically based on a variety of financial models, including:

- **Net present value (NPV):** The NPV is a measure of the profitability of a project. It is calculated by taking the present value of all future cash flows from the project and subtracting the initial investment. A positive NPV indicates that the project is expected to be profitable.
- **Internal rate of return (IRR):** The IRR is the discount rate that makes the NPV of a project equal to zero. It is a measure of the profitability of a project on an annualized basis. A higher IRR indicates that the project is expected to be more profitable.
- **Payback period:** The payback period is the time it takes for a project to recoup its initial investment. A shorter payback period indicates that the project is expected to be more profitable.

- **Location of the resource:** The project's proximity to a market for electricity or heat can affect the project's revenue stream.
- **Regulatory environment:** The project's compliance with environmental and other regulations can affect its costs and risks.
- **Political stability of / Social acceptance within the region:** Political instability or social acceptance can make it difficult to secure financing and complete the project.

- **Discounted cash flow (DCF):** The DCF is a method of valuing a project by taking into account the time value of money. It involves discounting future cash flows to their present value.
- **Real options:** Real options are a way of valuing flexibility in a project. They allow the developer to make decisions about the project as it progresses, which can increase its value.
- **Monte Carlo simulation:** Monte Carlo simulation is a statistical method that can be used to model the uncertainty of a project. It involves simulating the project many times over, using different assumptions about the input variables. This can help the developer to understand the range of possible outcomes for the project.



In addition to these financial models, developers may also use other models to assess the technical feasibility of a geothermal project, such as:

- **Geological models:** Geological models are used to map subsurface geology and to estimate the size and quality of the geothermal resource.
- **Hydrogeological models:** Hydrogeological models are used to model the flow of groundwater in the area and to identify potential drilling sites.
- **Equipment sizing models:** Equipment sizing models are used to determine the size and capacity of the geothermal equipment required for the project.

#### 4.1.2 Risk management & insurance

Throughout the realization of a geothermal project, various risks must be taken into account. These risks should be analyzed and realistically assessed with the goal of minimizing them (see [Figure 8](#)). Experts from all parties that are involved throughout the whole project process shall be involved and is very intensive in the beginning and throughout the process. Results are important for financial planning, insurance management and public relations.

The objectives of risk analysis and insurance in geothermal projects are:

- **Transparency of Feasibility to Investors:** To provide clear and accurate information about the project's feasibility to those who are investing.
- **Investor Protection:** To safeguard the interests and investments of those funding the project.

General note:

- Municipalities can finance projects through tax revenues and have the advantage of requiring less return than large companies.
- Large companies usually finance their projects through project participations and joint ventures.
- Especially deep geothermal projects are initially financed with equity or venture capital, as lenders only participate after a successful drilling.
- Crowdfunding, citizen participation and leasing are options, although they are not yet widely spread.

- **Insurance Against Technical Hazards and Damages:** This includes risks associated with drilling and surface facilities.
- **Insurance for Exploration Success:** This covers the rate of resource extraction and the temperature, essential factors in the economic viability of the project.

In geothermal projects, risks should be minimized as much as possible, but they can never be eliminated. Both financial and technical risks can occur. The most significant financial risks are often related to exploration success, i.e., whether the targeted aquifer can yield a commercially viable extraction rate. The risk of exploration failure can be significantly reduced through high-quality forecasting. This requires comprehensive preliminary investigations, complete geological data analysis, and potentially additional data acquisition such as exploration wells or seismic data acquisition.

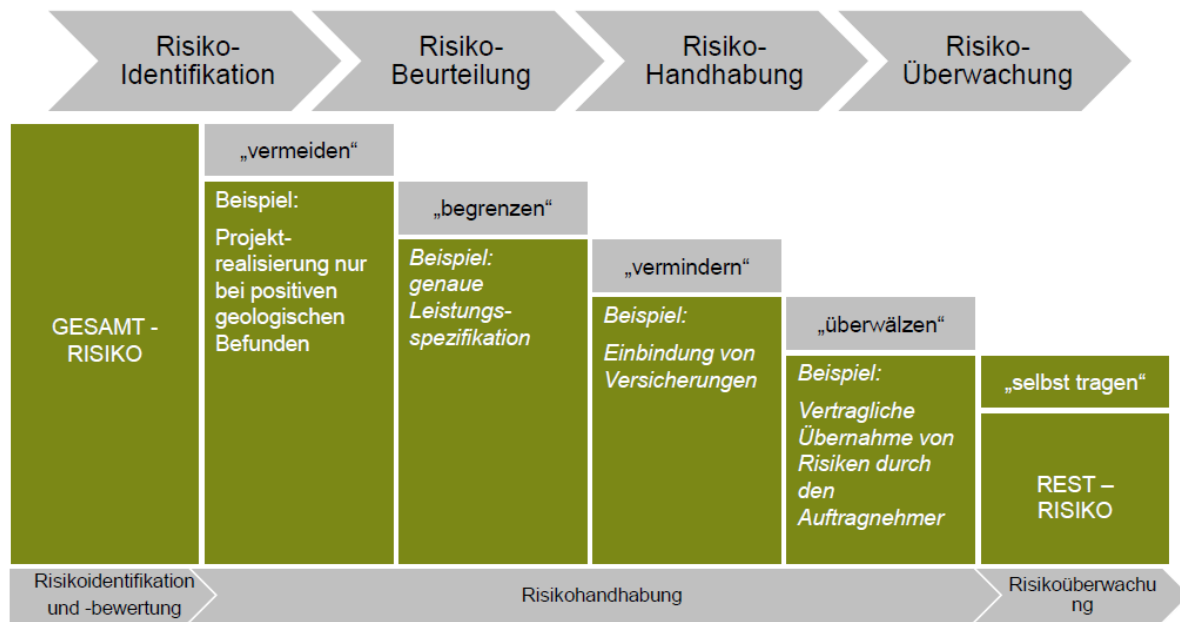

Figure 8: Process of risk management and scope/frame of insurance

#### 4.1.2.1 Risk profiles

Geothermal projects are subject to a variety of risks, which can be categorized into geological, technical, financial, regulatory, and environmental risks.

is always a risk of encountering technical problems during drilling, such as encountering unexpected geological formations.

#### 4.1.2.2 Geological risks

- **Resource uncertainty:** The presence of produceable hot water is essential for the development of geothermal projects. However, there is always some uncertainty about the size and quality of the resource. The presence of faults may affect the risk on seismicity.
- **Wellbore issues:** Drilling and wellbore construction are the most expensive components of a geothermal project. There

#### 4.1.2.3 Technical risks

- **Equipment failure:** Drilling and production equipment is complex and can be prone to failure. This can lead to downtime and lost revenue.
- **Scaling/corrosion:** Geothermal brines can be corrosive and may contain dissolved minerals that can form scale deposits in wells and heat exchangers. This can reduce the efficiency of the system and increase maintenance costs or well design costs.

#### 4.1.2.4 Financial risks

- **High upfront investment:** The upfront investment in a geothermal project can be significant. This can make it difficult to secure financing.
- **Long project duration:** Geothermal projects can take several years to develop and construct. This can make it difficult to finance the project and to keep costs under control.
- **Variable revenue stream:** The revenue from a geothermal project can vary depending on the price of electricity and the demand for heat. This can make it difficult to project cash flow and to secure financing.

#### 4.1.2.5 Regulatory risks

- **Permits and approvals:** Geothermal projects are subject to a variety of regulatory requirements, which can vary from country to country. These requirements can delay the project and increase costs.

- **Community opposition:** Geothermal projects can be controversial, as they may involve the use of public land and have the potential to affect groundwater resources. Community opposition can delay or derail the project.

#### 4.1.2.6 Environmental risks

- **Water contamination:** Geothermal fluids can contain dissolved minerals that can contaminate shallower formation layers or ground water if wells are not properly designed and managed.
- **Seismicity:** Geothermal extraction, i.e. cooling of subsurface, may cause seismicity.

Overall, the risk profile for geothermal projects is significant and will need to be well managed. However, the potential rewards are also high, as geothermal energy is a clean, sustainable, and cost-effective source of heat with a small footprint.

# Germany





## 4.2 Germany

The greenhouse gas emissions of Germany as one of the most important industrialised countries in the world shall be reduced by 95% compared to 1990 based on the “Klimaschutzplan 2050”.

This has been signed by the federal government of Germany in 2016 and shall be the German contribution to achieve the global goal of the Paris Climate Agreement from December 2015. Within this plan, different reduction goals for different sectors such as traffic, energy and industry are planned.

After a decision of the Federal Constitutional Court in Karlsruhe, that the goal of the “Klimaschutzplan 2050” is insufficient, the goal to be climate neutral has been pushed forward from year 2050 to 2045 (Bundesministerium für Umwelt, Naturschutz und nukleare Sicherheit (BMU), 2016). Intermediate goals had to be tightened and i.e. greenhouse gas emissions have to be reduced by 65% until 2030 instead of 55% (Bundesministerium für Umwelt, 2021).



The German federal state has the ambition set up and improve the existing laws to accelerate the transition especially on the heat sector: a triad out of “Gebäudeenergiegesetz” (GEG), Wärmeplanungsgesetz (WPG) and Bundesförderung Effiziente Gebäude (BEG) shall be improved.

With the decision from November 17<sup>th</sup> 2023 the Bundestag decided i.e. the publication of the “Wärmeplanungsgesetz” (WPG). Cities with more than 100.000 inhabitants have to prepare heat plans before June 30<sup>th</sup> 2026 and smaller ones latest June 30<sup>th</sup> 2028. Within this law new heat nets need to

be driven with 65% renewables or unavoidable waste heat, existing with min. 30% until 2030 and 80% until 2028. Funding is foreseen at approx. 500 million Euro.

With more than half of the total energy consumption, the heat supply currently contributes significantly to greenhouse gas emissions in Germany. In the building sector, heat predominantly comes from fossil energy sources such as natural gas and oil. This also makes Germany dependent on other countries what is not sustainable in the long run.

---

Municipalities, municipal utilities have therefore the need to set up a municipal heat planning concept, energy providers have to re-think their approaches to generate process heat, and building owners have to consider alternative heating methods. The earlier they can make forward-thinking decisions, the more cost-effective the future energy supply will be for everyone.

This is precisely where the Heat Planning Act comes in, as a heat plan serves as the strategic planning tool for the climate-neutral heat supply of the future. The importance of geothermal on this strategic path can be outlined by using the words of the (Bundesverband Geothermie e.V., 2023):

***“The pressure for action in the heating sector is enormous. We use over half of the final energy in Germany to heat our homes, offices, and businesses and to provide heat for commerce and industry. Therefore, the heat transition is crucial for achieving German and international climate goals and becoming less dependent on fossil fuels.***

***Geothermal energy can be a significant part of the solution to our energy challenges. The technology has the potential to cover large portions of our total heat consumption. However, the implementation of geothermal projects currently involves complex and lengthy approval and permitting procedures. From project development to the actual realization of a project, several years can pass.”***

The urgency to achieve the goals of the “Klimaschutzplan 2050” puts all players in a position where an immediate step towards the implementation of renewables such as geothermal heat and electricity supply where possible must be taken. With this step the level of dependency on the delivery

of resources from foreign countries will ideally be further decreased. By this the economical position of Germany will ideally be strengthened since investment can be saved on that end, which will on the other end be available for alternative strategic investment opportunities.

### 4.2.1 General

Geothermal energy is seen as a crucial technology for modernizing the country and ensuring Germany's industrial competitiveness. The Federal Ministry for Economic Affairs and Climate Action (BMWK) picked up that fact and emphasizes within its position paper (BMWK, 2022) the importance of geothermal energy as a key technology for the energy transition and aims to strengthen the utilization of geothermal energy for heat supply.

While shallow geothermal energy has been well developed, the potential of mid-depth and deep geothermal energy is still insufficiently exploited.

The aim is to achieve climate-neutral heat supply for buildings, new construction, and industrial processes by 2045. Measures such as efficiency improvements and the significant expansion of renewable energy sources, including geothermal energy, are necessary. The potential of geothermal energy to improve energy security and replace fossil fuels is there. However, there is a need to address access barriers, particularly for process-integration and long-term, stable market access for industries.



Germany is the first country to decommission turbines installed in geothermal combined heat & power plant to concentrate solely on heat supply. The Unterhaching combined heat and power plant closed its 3.4 MW power generation plant to focus on supplying heat to 7,000

households connected to its 47 km district heating network. However, this trend does not seem to be replicated at a large scale, at present. The electricity price crisis caused by the invasion of Ukraine radically changed this dynamic.



As of February 2022, there are 42 deep geothermal projects in operation in Germany, mainly based on hydrothermal utilization. The thermal capacity of these projects is 343 MWth. Different depth ranges require different technologies and have varying levels of development and funding needs. 17 projects are under development and 18 more are planned as of the end of 2023.

Geothermal energy is supported through different funding programs, including the Renewable Energy Sources Act for electricity generation and various programs for heat utilization.

The use of geothermal energy in Germany shall be expanded widely and thus contribute to achieving that fifty percent of heat is produced in a climate-neutral way by 2030 (Coalition Agreement).

Specifically, in medium and deep geothermal energy, a geothermal potential of 10 TWh is to be developed as far as possible by 2030, thereby increasing the current feed-in into heating networks from this source by tenfold (Initial Climate Protection Balance Sheet).



To achieve this, the aim is to initiate at least 100 additional geothermal projects by 2030, connect them to heating networks, and make geothermal energy usable in residential buildings, neighbourhoods, and industrial processes. This should provide a strong impulse (**fly wheel effect**), for further geothermal projects further develop the technology and prepare the market for the use of geothermal energy.

**Eight Measures** to achieve the goal have been defined in that context (see also **Reference source not found.**):

- I. **Dialogue Process with Stakeholders:** Engaging with stakeholders to ensure acceptance and consistency.
- II. **Data Campaign:** Systematic use of existing underground data to advance geothermal energy in Germany.
- III. **Exploration Campaign:** Qualifying at least 100 sites with good geothermal potential

and usable infrastructure for geothermal system development.

- IV. **Accelerating Approval Processes:** Identifying opportunities to optimize planning and approval procedures for geothermal projects.
- V. **Funding Programs:** Providing targeted funding to improve the competitiveness of geothermal systems.
- VI. **Risk Mitigation:** Exploring ways to reduce financial risks for project developers, including improved data and information.
- VII. **Skilled Workforce and Availability of Measurement and Drilling Equipment:** Addressing the shortage of skilled workers and promoting technical training.
- VIII. **Public Acceptance:** Promoting regional acceptance through information campaigns and transparency.



Figure 9: Overview – Measures to achieve the “geothermal” goal (BMWK, 2022)



Those measures are linked to the experience of operating geothermal wells and power plants for several decades. Projects in the east and especially in the south of Germany have had the strategic aim to support local municipalities with heat and electricity supply as well as setting up a sustainable independent provision of energy.

Geothermal energy already became interesting in the former DDR especially thanks to municipal drivers like Unterhaching, Pullach or Grünwald. Geothermal energy became also a very popular option to the standard energy sources in southern Germany. The city of Munich with its Stadtwerke and the Bavarian state understood this geological

present very well, and the strategic focus was directed towards this source. Supported by the Bundesverband Geothermie (BVG) other states like NRW, Berlin, Schleswig Holstein or cities widespread over the country are following this ideology and looking into the option to utilize this source very closely.

Master plans among studies for the municipal heat planning have been, are currently, or need to be set up i.e. on a research level together with the different institutions like Fraunhofer IEG, KIT, or LIAG while also state agencies like the HLNUG in Hessen and the LBEG in Lower Saxony supporting this process by setting up different guidelines to drive geothermal projects.



In the shadow of the municipal players on the market, private companies like Vulcan Energy Resources, Deutsche Erdwärme GmbH, Baker Hughes and Eavor GmbH are seeking the investment opportunity and start to set up projects.

However deep geothermal energy has so far been a niche player. The reason is simple - the 'economic playing field' is

uneven, as i.e. outlined in a presentation of H. Mangold ( (Innovative Energie Pullach, 2023) or (Philippe Dumas, 2017), p.199/chapter 3.2. Various forms of unequal treatment like the preference of fossil heat sources still push geothermal energy to the side or don't even let it in the game. For many people in the country the time has come now to reset the course for the heat transition.

---

For this, the **right framework conditions** are needed. Because the Renewable Energy Sources Act (EEG), the Combined Heat and Power Act (KWK-Gesetz), and the Tenancy Law Amendment Act have only inadequately accounted for geothermal energy. Municipalities and companies need economic framework conditions to advance the heat transition more effectively and with greater electricity savings. The COVID-19

pandemic has also taught us that the foundation of our coexistence and stability is an autarkic, regional value creation. Deep geothermal energy is an autarkic, regional value creation – it makes us independent of energy imports from politically unstable regions. Promoting local geothermal energy fundamentally makes sense in the following areas:

- 1. Research in the fields of geological reservoirs, exploration, and storage.*
- 2. A risk fund for exploration to secure against the risk of non-discovery.*
- 3. 'Level playing field' for the construction and operation of geothermal facilities.*
- 4. Support for private households transitioning from a fossil-fuel-based to a geothermal heating system.*
- 5. Funding for connecting pipelines between geothermal heating plants and district heating networks, and between different district heating networks."*

Unfortunately, the driving mechanism came to a sudden stop mid of November 2023 after the ruling of the Federal Constitutional Court in Karlsruhe. The reallocation of funds intended for combating the COVID-19 pandemic to be used for climate protection is unconstitutional.

Following the decision in Karlsruhe, it is currently unclear how central funding instruments, which were supposed to support the expansion of renewable energies, are to be financed in the medium and long term. Geothermal energy is also severely affected. The consequences for the heat transition and climate protection are dramatic. The federal government must now quickly find a way to make the financing of the energy transition reliable and

sufficient. To tap into the great potentials of geothermal energy for the decarbonization of our heat supply, a secure funding landscape is needed. The industry urgently requires planning security for its investment decisions.

Currently, there is a funding freeze for the energy consulting programs (EBN and EBW), the Federal Funding for Efficient Heating Networks (BEW), and the Federal Funding for Energy and Resource Efficiency in the Economy (EEW). Already approved funding notices are not affected by this freeze. However, further applications are currently not being approved on a provisional basis. Only the Federal Funding for Efficient Buildings (BEG) is not affected by this.

#### **4.2.2 Financial instruments**

Germany has implemented a variety of financial instruments to support the development of geothermal projects, acknowledging the potential of geothermal

energy to contribute to its energy transition goals. These financial instruments can be broadly categorized into subsidies, tax incentives and public-private-partnerships:

### **A) Subsidies**

The German government provides direct subsidies to geothermal projects through various programs, such as the Renewable Energy Sources Act (EEG) and the Geothermische Ressourcenförderungsgesetz (GRefG). The EEG offers feed-in tariffs for geothermal electricity, providing a guaranteed price for the electricity generated by geothermal plants. The GRefG provides grants and loans for geothermal exploration and development projects, particularly in areas with high geothermal potential but limited economic viability.

*For details on the various subsidy schemes a separate document containing an interview w/ BVG is internally available.*

## B) Tax Incentives

Germany also offers tax incentives to geothermal projects, including accelerated depreciation for geothermal equipment and investment tax credits. These incentives can help reduce the financial burden of investing in geothermal projects, making them more attractive to investors.

## C) Partnerships

Public-Public (PUPs) as well as Private-Public (PPPs) Partnerships have been utilized for geothermal projects in Germany, combining public funding with private investment. These partnerships can pool resources and expertise from both the public and private sectors, facilitating the development of large-scale geothermal projects.

A variety of financial instruments have been utilized to execute geothermal projects in Germany. These instruments can be broadly categorized into public and private financing options.

*Various examples of financing have been analyzed and content of a separate internal document.*

## D) Public financing:

Renewable Energy Sources Act (Erneuerbare-Energien-Gesetz, EEG):

This law provides various subsidies and incentives for geothermal projects, including feed-in tariffs, tax exemptions, and loan guarantees.

Investment Grants: The German government has provided on a national state level investment grants and subsidies to support the development and implementation of geothermal energy projects. These grants help to cover a portion of the upfront capital costs associated with drilling and infrastructure development.

KfW: KfW is a German development bank that offers financing for renewable energy projects, including geothermal. KfW offers a variety of loan programs, including loans with interest rates below the market rate.

European Union Funding: Germany has accessed funding from the European Union (EU) to support renewable energy projects, including geothermal. EU programs and initiatives like Horizon 2020 and the European Structural and Investment Funds (ESIF) provide financial support for geothermal initiatives.

European Investment Bank (EIB): The EIB is a European Union bank that provides loans for renewable energy projects, including geothermal. EIB loans can be used to finance the construction and operation of geothermal projects.

## E) Private financing:

**Equity financing:** Private equity firms can invest in geothermal projects in exchange for ownership shares.

This can provide project developers with the capital they need to finance the development and construction of geothermal projects.

**Debt financing:** Banks and other lenders can provide loans to project developers for geothermal projects. Debt financing can be used to finance the construction and operation of geothermal projects.

The public and private financing options outlined above are the most common methods of financing geothermal projects in Germany.



### 4.2.2.1 Examples of utilized financial instruments & insurances

*For details on the various examples of utilized financial instruments & insurances a separate document is internally available.*

### 4.2.3 Governance

The governance for geothermal projects in Germany is complex and involves various levels of government, including the federal government, the Länder (federal states), and local authorities.

The federal government has set the overall policy framework for geothermal development, while the Länder and local

authorities are responsible for issuing permits and overseeing projects.

### 4.2.3.1 Federal Government

The federal government's primary role in geothermal governance is to set the legal and regulatory framework for project development. This includes the Mineral Resources Act (Berggesetz) and the Heat Supply Act (Wärmeversorgungsgesetz), which provide the legal basis for geothermal exploration, drilling, and energy production.

The federal government also provides funding for geothermal research and development through the Federal Ministry for Economic Affairs and Climate Action (BMWi).



#### 4.2.3.2 Länder and Local Authorities

The Länder and local authorities are responsible for issuing permits for geothermal projects and overseeing their implementation.

This includes conducting environmental assessments, ensuring compliance with noise and air pollution regulations, and protecting groundwater resources. Landesamt für Geologie, Rohstoffe und Bergbau (LGRB) is the main authority responsible for geothermal project approvals in Bavaria.

#### 4.2.3.3 Permits and Licensing

The specific requirements for obtaining permits for geothermal projects vary depending on the type of project, the location, and the depth of the geothermal reservoir. However, in general, developers will need to obtain the following permits:

- *Water law permit for groundwater abstraction*
- *Environmental impact assessment (EIA)*
- *Construction permit for drilling and installation of infrastructure*
- *Operating permit for energy production*

#### 4.2.3.4 Environmental Impact Assessment

The EIA is a crucial part of geothermal project development, as it assesses the potential environmental impacts of the project. This includes potential impacts on groundwater resources, air quality, noise, and biodiversity. The EIA must be conducted by an independent expert and approved by the relevant authorities.

#### 4.2.3.5 Community Engagement and Public Participation

Community engagement and public participation are an important aspect of geothermal project development in Germany. Developers are required to consult with local communities and stakeholders throughout the project lifecycle. This includes informing the public about the project's plans, addressing concerns, and seeking input.



#### 4.2.3.6 Financial Incentives

The German government provides a range of financial incentives for geothermal projects, including subsidies, tax breaks, and loan guarantees. These incentives are designed to encourage the development of geothermal energy and help make it more cost-competitive with other forms of energy.

#### 4.2.3.7 Future Outlook

Germany is committed to increasing the use of geothermal energy as part of its efforts to achieve its climate goals. The government aims to have at least 100 new geothermal projects operational by 2030. To achieve this goal, the government will need to continue to streamline the permitting process, provide financial incentives, and encourage community engagement.

#### 4.2.3.8 Examples

A) Bundesministerium für Wirtschaft und Energie - Guidelines for the Promotion of Measures for the Use of Renewable Energies in the Heat Market, Market Incentive Program for Renewable Energies in the Heat Market (MAP) (BMWK, 2020)

B) Pakt für Planungs-, Genehmigungs- und Umsetzungsbeschleunigung zwischen Bund und Ländern (coalition agreement):

to implement necessary transformations in Germany.

- Goal – secure the competitiveness of the German economy, transform the country sustainably, and achieve climate protection goals.
- Public and private projects need to be realized faster and with less bureaucracy in order to create affordable housing and ensure an environmentally friendly and efficient infrastructure.

#### Outline:

- Need for a significant acceleration of planning and approval procedures in order

#### Solutions:

**Table 2: Coalition Agreement – Acceleration agreement between federal government and state (MPK, Bundeskanzler, 2023)**

<b>Procedures and Processes</b>
<i>To implement transformation processes quickly, optimization of planning and approval procedures is necessary.</i>
<i>The focus should be on evaluating previous procedures, questioning the requirements, and addressing identified obstacles to streamline processes.</i>
<i>The goal is to reduce the formal and material examination scope to the necessary extent and make use of EU requirements to expedite procedures.</i>
<i>Effective and results-oriented communication between project stakeholders is emphasized, and opportunities for public participation should be maximized.</i>
<b>General Procedural Law</b>
<i>- Early and effective communication between project stakeholders and authorities is encouraged, and redundant participation and communication processes are to be avoided.</i>
<i>- The use of digital means for public participation is highlighted, and the establishment of digital platforms for environmental data is planned.</i>
<i>- The aim is to simplify the availability and documentation of environmental and species protection data and to enable better utilization of existing information.</i>
<i>- Flexibility and simplification of procedures are proposed for smaller and similar projects where the risks are low.</i>
<b>Expansion of Energy Infrastructure</b>

*The expansion of energy infrastructure is hindered by landowners' refusal to allow access to existing networks and equipment.*

*The government plans to legislatively enforce the obligation of landowners to allow access and to introduce compensation requirements to prevent delays caused by lengthy negotiations.*

*The simplification of procedures and requirements for environmental impact assessments is proposed for the expansion of energy infrastructure projects.*

#### **Environmental Impact Assessment**

*The government aims to utilize flexibility within the law to allow exceptions and increase the thresholds for certain environmental impact assessments.*

*The possibility of exempting certain changes and modernizations from comprehensive environmental impact assessments is being explored.*

*The goal is to reduce the length and complexity of approval procedures while still ensuring environmental compatibility.*

#### **Immission Control Law**

*Evaluation of optional environmental impact assessments and the effects of specific regulations on gas supply is being conducted to identify potential acceleration measures.*

*The implementation of EU emissions reduction techniques into national law is prioritized to provide sufficient time for operators and authorities to adopt new regulations.*

*Flexible use of approved substances and operational modes within defined frameworks is proposed to simplify and accelerate approval procedures.*

*The establishment of a nationwide environmental data registry and database for expert opinions is considered to facilitate future projects and reduce duplication of effort.*

#### **Legal Planning**

*Measures for accelerated approval and implementation of significant infrastructure projects are being explored.*

*The possibility of introducing a long-term approval mechanism by the legislature is being considered, while ensuring opportunities for legal recourse.*

*Joint decisions and agreed frameworks are proposed to reduce redundancy and accelerate the planning process.*

#### **Building Law**

*Amendments to the building code are planned to digitize planning processes and simplify public participation procedures.*

*The goal is to enable faster implementation of building projects, including the conversion of existing buildings and the creation of affordable housing.*

*Harmonization of regulations and guidelines among the states is emphasized to streamline building approval processes.*

---

### C) Law on Municipal Heat Planning

Link - 17.11.2023: [Bundesverband Geothermie: Bundestag billigt Gesetz zur kommunalen Wärmeplanung](#)

### D) Expenditure freeze:

15.11.2023 - Federal government freezes expenditure in climate fund (Deutschlandfunk, 2023):

- Due to a decision of the Bundesverfassungsgericht (translation: Federal Constitutional Court) the finance minister has frozen expenditures for the “Klima- und Transformationsfond” for the next two years.

- A new economic plan has to be worked out
- Minister of Economic Affairs is confident that several subsidies such as support for Geothermal still can be adhered to

Link - [Bundesverband Geothermie: Haushaltssperre: Geothermie droht zur verpassten Chance zu werden](#)

Link - [Hammer-Urteil würde uns „hart treffen“: Brutaler Habeck-Satz aufgetaucht! | Politik | BILD.de](#)

Link - 17.11.2023 - [Bundesverband Geothermie: Nach Haushaltsurteil: BVG-Präsident fordert Absicherung der Geothermie-Finanzierung](#)

## 4.2.4 Social acceptance

The acceptance varies from site to site, depending on prior experiences with the technology. In the Molasse Basin, there are no discernible acceptance challenges, while in the Upper Rhine Graben, geothermal energy is mainly opposed by opponents. In the North German Basin, deep geothermal energy enters the public consciousness, but it took several years because the local facilities were implemented before 1990.

The social acceptance of geothermal energy in Germany is a complex issue with

both positive and negative aspects. Compared to the Netherlands the public opinion seems less biased because no men-induced earthquakes occurred for years without proper action from the government what affected besides the social acceptance also the governance of mining projects (the geological situation & seismicity action near the sites Landau and Insheim in the Oberrhein-Graben area may be an exception, monitoring programs are in place for observation purpose.

### 4.2.4.1 Positive Aspects

- **Addressing Climate Change Concerns / Renewable and sustainable energy source:** Deep geothermal energy is recognized as a renewable and sustainable energy source, capable of significantly reducing greenhouse gas emissions and contributing to Germany's climate change mitigation goals. This aligns with the growing public awareness and concern about climate change, making deep
- **Local and distributed energy source:** Geothermal energy can be

geothermal projects more appealing to the public.

- **Stable Energy Supply and Diversification:** Deep geothermal energy provides a reliable and stable energy source, independent of weather conditions or fossil fuel prices. This diversification of the energy mix reduces reliance on traditional sources and contributes to energy security.

harnessed locally, reducing the need for long-distance power transmission and



reliance on centralized power grids. This can promote energy independence and resilience in local communities.

- **Community Engagement and Transparency:** German developers and authorities have emphasized early and ongoing engagement with local communities throughout the project lifecycle. This includes open communication, transparent information sharing, and inclusive participation in decision-making processes. Such proactive engagement has helped to build trust, address concerns, and foster a sense of shared ownership among stakeholders.

- **Economic Benefits and Local Development:** Deep geothermal projects offer potential economic benefits to local communities, including job creation, tax revenue, and enhanced energy security. Developers are increasingly incorporating community-based ownership models, allowing local residents to participate in the economic gains and fostering a sense of ownership and support for the project.

- **Regulatory Framework and Risk Mitigation:** Germany has a comprehensive regulatory framework for deep geothermal projects, ensuring adequate risk assessment, environmental monitoring, and public safety measures. This framework promotes responsible development while addressing potential concerns.

- **Policy Leadership:** Germany's embracement of geothermal energy positions it as a leader in renewable energy policy, setting an example for other countries in terms of environmental stewardship and transition to sustainable energy sources.

- **Case Studies and Success Stories:** The successful operation of

various deep geothermal projects in Germany have provided positive examples and demonstrated the feasibility of this technology. These success stories have helped to build public confidence and acceptance.

- **Continuous Improvement and Lessons Learned:** German authorities and developers actively share lessons learned from both successful and challenging deep geothermal projects. This continuous improvement process helps to refine practices, address shortcomings, and enhance the overall social acceptance of these projects.

- **Technology Advancement and Innovation:** Germany has a strong track record of research and development in deep geothermal technology, leading to advancements in drilling techniques, heat extraction methods, and environmental monitoring systems. These technological advancements enhance the efficiency and sustainability of deep geothermal projects, further strengthening public support.

- **Potential for baseload power supply (locally):** Geothermal energy can provide a baseload power source, meaning it can generate electricity at a steady rate, even in periods of low demand or extreme weather conditions. This can help to stabilize the electricity grid and reduce reliance on fossil fuels for backup power.

- **Role of Local Authorities and Stakeholder Cooperation:** Local authorities play a crucial role in facilitating communication, mediating disputes, and coordinating stakeholder involvement. Their engagement fosters a collaborative approach and helps to address community concerns effectively.

By addressing climate concerns, prioritizing community engagement, promoting economic stability and benefits, demonstrating technological advancements, learning from case studies, refining regulations, and fostering

cooperation, Germany has fostered a positive social acceptance for deep geothermal projects. This acceptance is essential for the continued development and deployment of this clean and sustainable energy source.

#### 4.2.4.2 Negative Aspects

- **Environmental concerns:** Some geothermal projects have raised concerns about potential environmental impacts, such as groundwater contamination, induced seismicity, and visual impacts from drilling rigs and surface installations. These concerns can lead to public opposition and delays in project approvals.

- **Public perception and trust:** Deep geothermal projects often involve significant infrastructure and land use changes, which can lead to community resistance and opposition from individuals and local groups. This resistance can be fueled by concerns about noise, traffic, visual impacts, and the potential for property value depreciation. Open communication, transparent information sharing, and inclusive participation in decision-making can help to address these concerns and build support for the projects.

- **Technical challenges and high costs:** Overall the technical challenges involved in drilling and maintaining wells can lead to high upfront costs and potential risks of technical failures.

- **Lack of Long-Term Data and Proven Track Record:** While there have been successful deep geothermal projects in Germany, the technology is still relatively new, and there is limited long-term data on its performance and environmental impacts. This lack of data can lead to uncertainty and apprehension among the public.

- **Perception of Risk and Unfamiliarity:** Deep geothermal technology is less familiar to the public compared to other renewable energy sources like solar and wind power. This lack of familiarity can contribute to a perception of risk and uncertainty, making it more challenging to gain acceptance for deep geothermal projects.

- **Lack of Transparent and Consistent Communication:** In some cases, the lack of transparent and consistent communication between developers, authorities, and local communities can exacerbate concerns and hinder social acceptance. Open communication, regular information sharing, and inclusive participation are crucial for building trust and addressing community concerns effectively.

- **Uncertainty about Permitting Processes:** The permitting process for deep geothermal projects can be lengthy and complex, which can lead to delays and uncertainty for developers and communities. Streamlining the permitting process and providing clear guidance can help to improve transparency and foster public confidence.

- **Lack of Public Information and Education:** Limited public information and education about deep geothermal technology can contribute to misconceptions and apprehension.

Addressing the public's concerns through educational campaigns and community engagement can help to promote understanding and acceptance.

- **Insufficient Monitoring and Risk Management:** Inadequate monitoring and risk management practices can raise concerns about potential environmental impacts and public safety. Robust monitoring systems, clear risk assessment protocols, and transparent reporting mechanisms are essential for building trust and mitigating risks.

- **Lack of Long-Term Government Support:** Sustained government support and financial incentives can play a crucial role in overcoming the challenges associated with deep geothermal projects. Long-term commitment to research and

development, funding for demonstration projects, and support for community engagement are essential for fostering public acceptance and driving the advancement of this technology.

Overcoming these challenges and building widespread social acceptance for deep geothermal projects in Germany requires a multi-pronged approach that addresses both technical and communication aspects. By prioritizing open communication, transparent information sharing, early and ongoing community engagement, and risk mitigation measures, the positive aspects of deep geothermal energy can be highlighted, concerns can be addressed effectively, and the path towards wider acceptance can be paved.

#### 4.2.4.3 Example

A good reference in that is the „Forschungsprojekt TIGER (Tiefe Geothermie: Akzeptanz und Kommunikation einer innovativen Technologie, FKZ 0325413A-C) (2017)“ which focused on acceptance of deep geothermal projects (publication as

book available). The work has carried out with 5 active partners (Landau, Insheim, Traunreut, Eich, Siebeldingen).

Factors which are acceptance-promoting and -inhibiting are outlined and summarized in the figures below:

keine Nachhaltigkeit Eigentumsschäden Erdbeben Grundwassergefährdung Lärm  
Kosten unbekannte Risiken

Figure 10: Results (TIGER) – CON

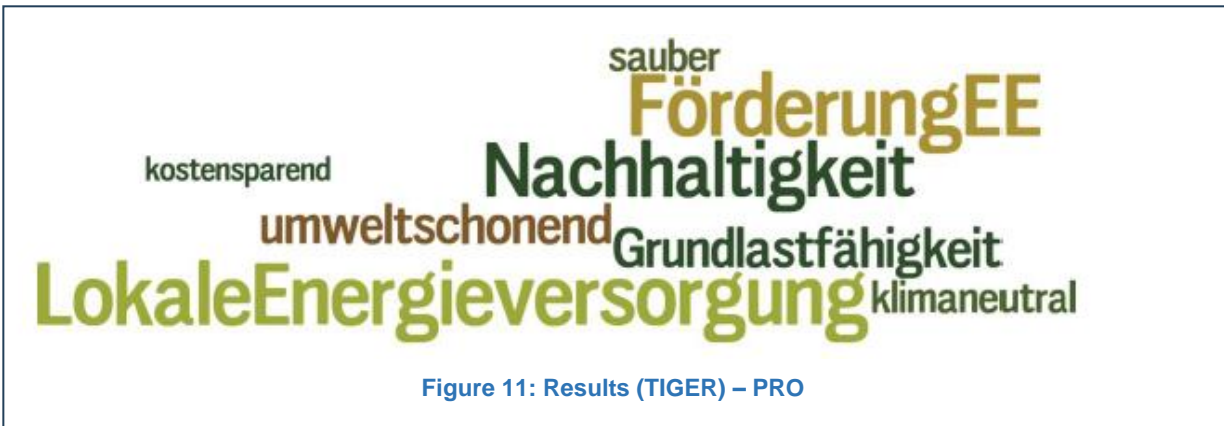

### 4.2.5 Permitting

The permitting process for geothermal projects in Germany is complex and involves multiple levels of government. The overall approval process is governed by the

Federal Mining Act (Bundesberggesetz), which is complemented by the Water Act (Wasserhaushaltsgesetz) and the Building Code (Baugesetzbuch).

#### 4.2.5.1 Process

The permitting process is well described in Figure 15 page 43 and the following schematic (Rödl & Partner, 2023).

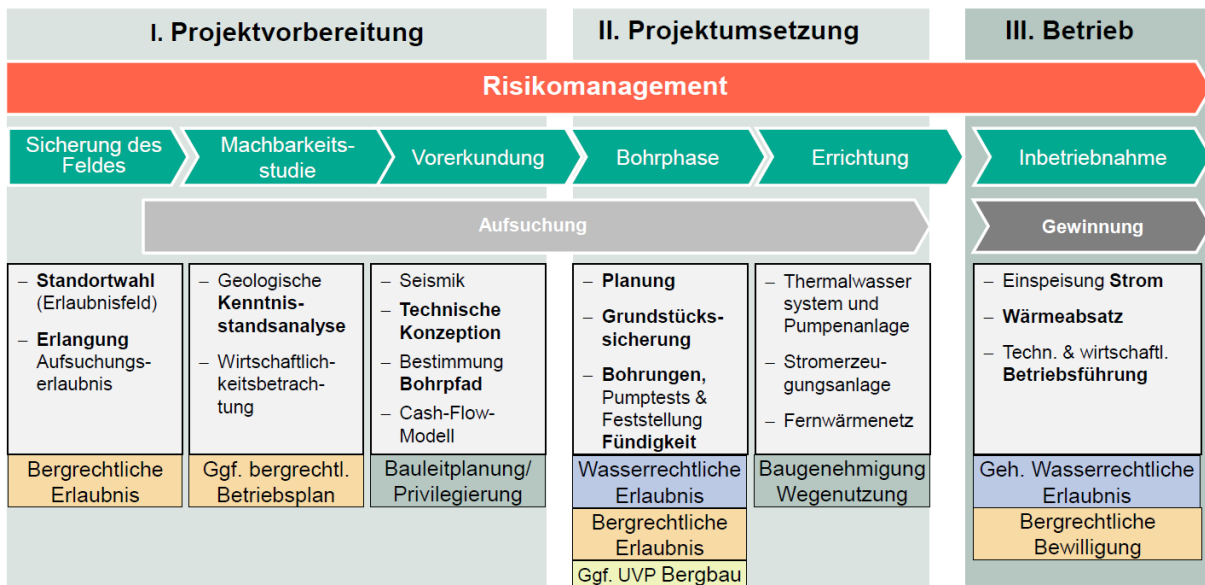

Figure 12: Permitting process – Germany (Rödl & Partner, 2023)

#### 4.2.5.2 Timeline

The entire permitting process for geothermal projects can take several years to complete. The specific timeline will depend on the complexity of the project and the level of public interest. In general, the exploration permit process takes around

one year, the mining permit process takes around two years, and the water law permit and building permit processes take around one year each.

Two examples of a typical project timeline for a geothermal project in Germany are

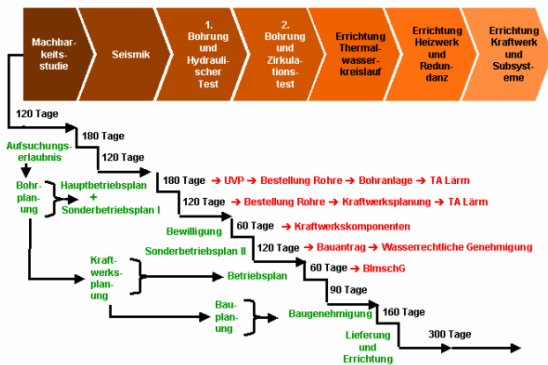

Figure 13: Timeline for a geothermal project among all phases (example) (TSB - Transferstelle Bingen, 2005)

outlined below. The process requires a minimum of 4 to 5 years:

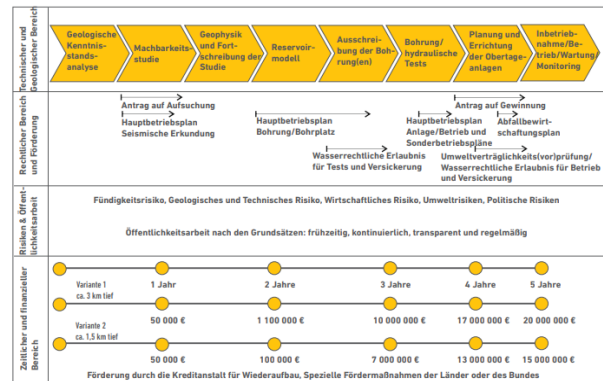

Figure 14: Time line for a geothermal project among all phases (example) (GTN, 2017)

#### 4.2.5.3 Exploration Permit

The first step in the permitting process is to obtain an exploration permit. This permit allows the developer to conduct preliminary investigations to assess the geothermal potential of a site. The application for an exploration permit must include a detailed description of the proposed drilling program, the expected geothermal resources, and the potential environmental impacts.

The exploration permit is typically granted by the state mining authorities (Länderbergämter) or the Federal Institute for Geosciences and Natural Resources (BGR). The permit is valid for a limited period of time, typically five years, and may be extended if additional exploration is required.

#### 4.2.5.4 Mining Permit

Once the developer has identified a suitable geothermal resource, they can apply for a mining permit. This permit allows the developer to extract geothermal fluids from the ground. The application for a mining permit must include a detailed description of

the proposed drilling equipment, the expected production rates, and the plans for handling and disposing of waste fluids.

The mining permit is granted by the state mining authorities (Länderbergämter). The permit is valid for a renewable period of 25 years and may be extended if the geothermal resources are still being exploited.

#### 4.2.5.5 Water Law Permit

Geothermal projects may require a water law permit if they are located in an area with groundwater protection zones. The water law permit is granted by the state water authorities (Landeswasserbehörden) and regulates the extraction, use, and discharge of geothermal fluids.

#### 4.2.5.6 Building/construction Permit

Finally, the developer must obtain a building permit for the construction of the geothermal power plant or heating facility. The building permit is granted by the local building authorities (Bauaufsichtsbehörden) and ensures that the facility complies with all applicable building codes and regulations.



---

#### 4.2.5.7 Public Participation

The permitting process for geothermal projects is open to public participation. Interested parties can submit comments on the project during the public consultation period. The developer is required to respond to these comments and address any concerns raised by the public.

#### 4.2.5.8 Challenges

The permitting process for geothermal projects can be challenging due to the complex regulations and the need to address potential environmental concerns. Developers may also face opposition from local communities who are concerned about the impact of the project on their land, water resources, and quality of life.

Despite these challenges, the permitting process for geothermal projects in Germany is becoming more streamlined and efficient. This is due to increasing support for renewable energy and a growing recognition of the benefits of geothermal energy.

#### 4.2.6 Legislation

The legislation for geothermal projects in Germany is governed by a multitude of laws and regulations at various levels of government. The primary federal legislation is the Geothermal Energy Heat Act (EEWärmeG), which sets out the framework for the exploration, development, and utilization of deep geothermal energy for the generation of heat and electricity. The Federal Mining Act (BbergG) also applies to geothermal projects, particularly in terms of subsurface rights and the protection of mineral resources.

In addition to federal laws, there are also relevant state-level regulations, such as the Bavarian Geothermal Energy Act (BayErlG) and the Hesse Geothermal Energy Act (Hessisches Erdwärmegesetz). These state-level laws often provide more detailed provisions on permitting processes,

environmental impact assessments, and public participation.

The Geothermal Energy Heat Act establishes a permit system for geothermal projects, requiring developers to obtain a permit from the competent authority before undertaking any exploration or development activities. The authority responsible for issuing permits varies depending on the depth of the project and the planned use of the geothermal resources. For example, in Bavaria, the Bavarian State Office for Geology and Mining (LfU) is responsible for permits for deep geothermal projects, while municipalities are responsible for permits for shallow geothermal projects.

During the permitting process, the applicant must provide detailed information about the proposed project, including the location of the wells, the expected depth of drilling, the planned method of heat extraction, and the environmental impact assessment. The competent authority will then assess the project against various criteria, such as its technical feasibility, environmental impact, and economic viability.

The Environmental Impact Assessment Ordinance (UVP) also plays a role in regulating geothermal projects, requiring developers to conduct an environmental impact assessment (EIA) for projects with a significant environmental impact. The EIA must identify and assess the potential environmental impacts of the project, including impacts on air quality, groundwater, soil, biodiversity, and landscape.

In addition to environmental regulations, geothermal projects must also comply with other relevant laws, such as the Water Resources Management Act (WHG), which protects water resources from pollution and depletion. The Building Code (BauGB) also applies to geothermal projects, particularly in terms of site selection and land use planning.

The development of geothermal energy in Germany is supported by various incentives and funding programs. For example, the Federal Ministry for Economic Affairs and Climate Action (BMWi) offers grant programs for the development of geothermal projects, and the Renewable Energy Sources Act (EEG) provides subsidies for the generation of electricity from geothermal sources.

Overall, the legislation for geothermal projects in Germany is designed to promote the responsible and sustainable development of this renewable energy

source. The combination of federal and state-level laws, as well as environmental regulations and incentives, helps to ensure that geothermal projects are properly planned, assessed, and implemented in a way that minimizes environmental impacts and maximizes the benefits for society.

#### 4.2.6.1 Example

The legislation is well described in various sources. One example is outlined below:

A) *Arbeitsgemeinschaft für Sparsamen und Umweltfreundlichen Energieverbrauch e.V. (ASUE, 2011) / (page 19):*

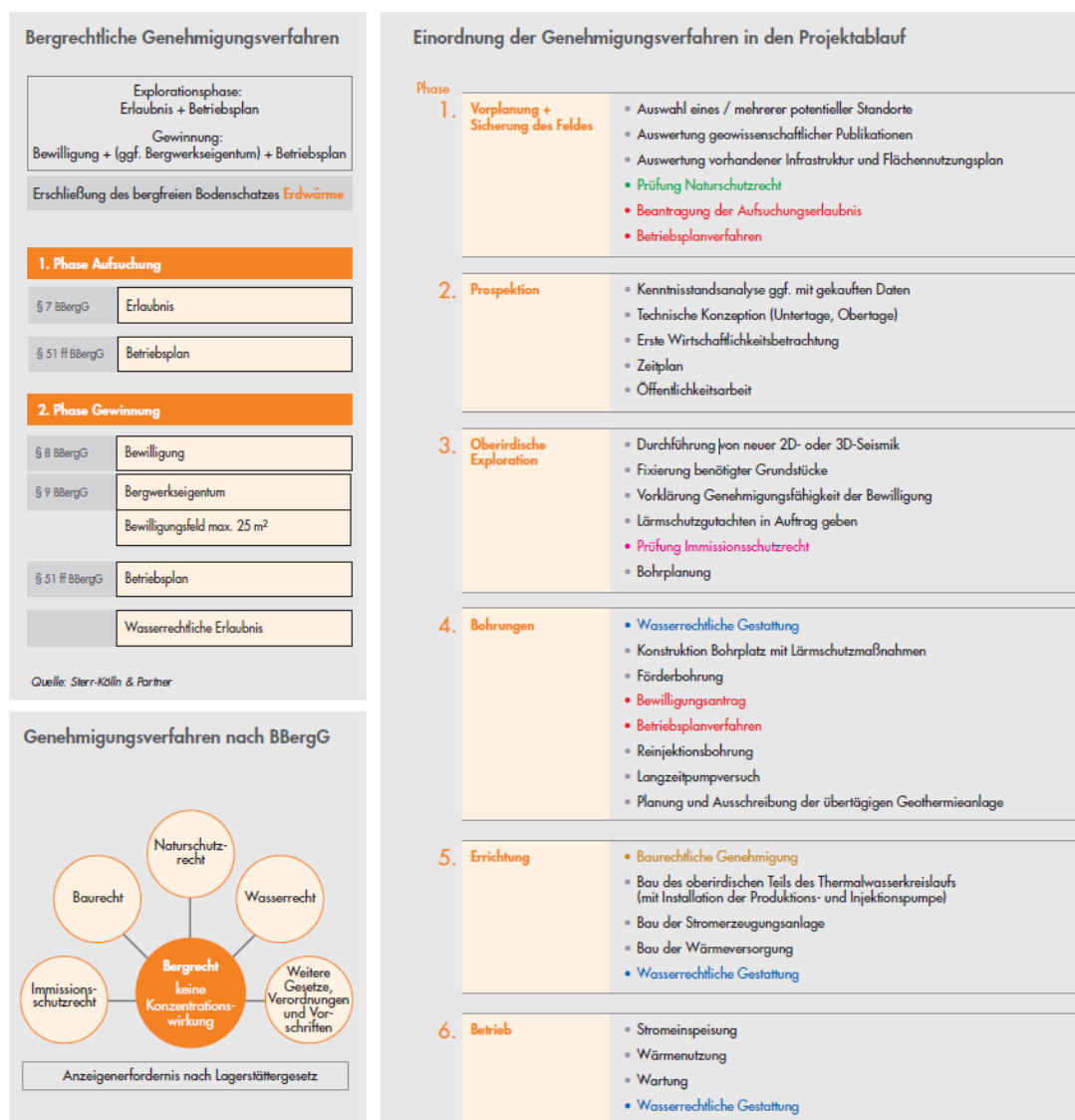

Figure 15: Legislation / Permitting Process (GER) (ASUE, 2011)

#### 4.2.7 Technology

The successful implementation of geothermal projects in Germany requires a comprehensive understanding of technological aspects, coupled with careful planning, rigorous risk assessment, and ongoing monitoring to ensure long-term sustainability and environmental protection.

#### 4.2.8 Hurdles / threats

**1. Big variety of approaches to execute geothermal projects** – every project seems nevertheless/still to be somehow “tailor made”.

- Financing, planning (i.e. baseline: O&G planning approach, HOAI, AHO, else – depending on type of operator (public/private)), operational aspects
- Varying roadmaps (whereby the core message/approach is more or less the same)

**2. Different states with different mining authorities.**

Varying legislative basis/experience with deep wells.

#### **3. Legislation.**

Slow adaption of legal framework condition.

- Angle of VKU (Verband kommunaler Unternehmen) - Faster progress in setting the legal framework conditions needed, request for consistent alignment of laws with investment activity and an urgent implementation of the discovery risk insurance announced in the coalition agreement (*HasePost, 2023*).
- Angle of CDU/CSU (opposition in the current government) - Utilize the potential of geothermal energy – reduce barriers, minimize risks, relieve the electricity sector (*CDU/CSU, 2023*).

**4. Projektträger Jülich (PtJ)** as the central organization of the government to

decide on where funding for research is going to.

- long decision time
- applicant is not allowed to do any work before funding has been evaluated/decided.

#### 4.2.9 Specific recommendations/options

Based on local experiences some examples have been specifically selected and are outlined below to display some ideas that may be an option for Dutch projects:

##### 4.2.9.1 Build strong alliances/partnerships (examples).

#### A) On education level

5. Geothermie Allianz Bayern - Teilprojekte unserer Forschung

#### Teilprojekte

1. effizient. Wärmewende durch intelligente Nutzung der Tiefengeothermie
2. regional. Neue Potentiale systematisch erkunden
3. sozial. Klimaschutz durch eine sichere Technologie
4. langfristig. Die Thermalwasserproduktion nachhaltig gewährleisten

#### B) On state / municipal level - professional exchange

- Berlin-Brandenburg (Geoenergieallianz Berlin-Brandenburg gegründet - Fraunhofer IEG)
- NRW (Zusammenschluss will Wärmewende in Nordrhein-Westfalen voranbringen - Fraunhofer IEG)
- Municipalities – Grasbrunn, Haar, Vaterstetten, Zorneding – “Inter-municipal Development Company” - Interkommunale Fördergesellschaft GEMO gegründet | Informationsportal Tiefe Geothermie.

- Planned geothermal plant shall be run as separate company (SPV)
- Baseline for setting up the company – feasibility study for geothermal wells and economic efficiency.
- Assumed cost (w/o heat net) 50 Mio €
- Improved economic efficiency due to shared risk.

### C) On state/municipal level – technical level

Connect the local heat networks.

- Unterhaching & Grünwald,
- SW München – Heat network with surrounding municipal geothermal projects.

Carry out an „inter-municipal“ seismic campaign.

- Link [Projektstart „Seismik GIGA-M“ für den geothermischen Ausbau in München | Informationsportal Tiefe Geothermie](#)

### D) On private – public – partnership level

*Deutsche Erdwärme – ForstBW*

- Cooperation enables Deutsche Erdwärme to access a site which is owned by ForstBW (forest owner).

#### 4.2.9.2 State level

*Applicable from 01.01.2024 – Federal Government Legislation for Heat Planning and Decarbonization of Heat Networks – Aim for climate neutral heating until 2045*

Reference:

- Deutscher Bundestag Drucksache 20/9344 Beschlussempfehlung und Bericht des Ausschusses für Wohnen, Stadtentwicklung, Bauwesen und Kommunen (24. Ausschuss),
- Wärmeplanungsgesetz für klimaneutrale Fernwärme | Bundesregierung.

#### 4.2.9.3 Federal State level – example: Nordrhein-Westfalen

Market development:

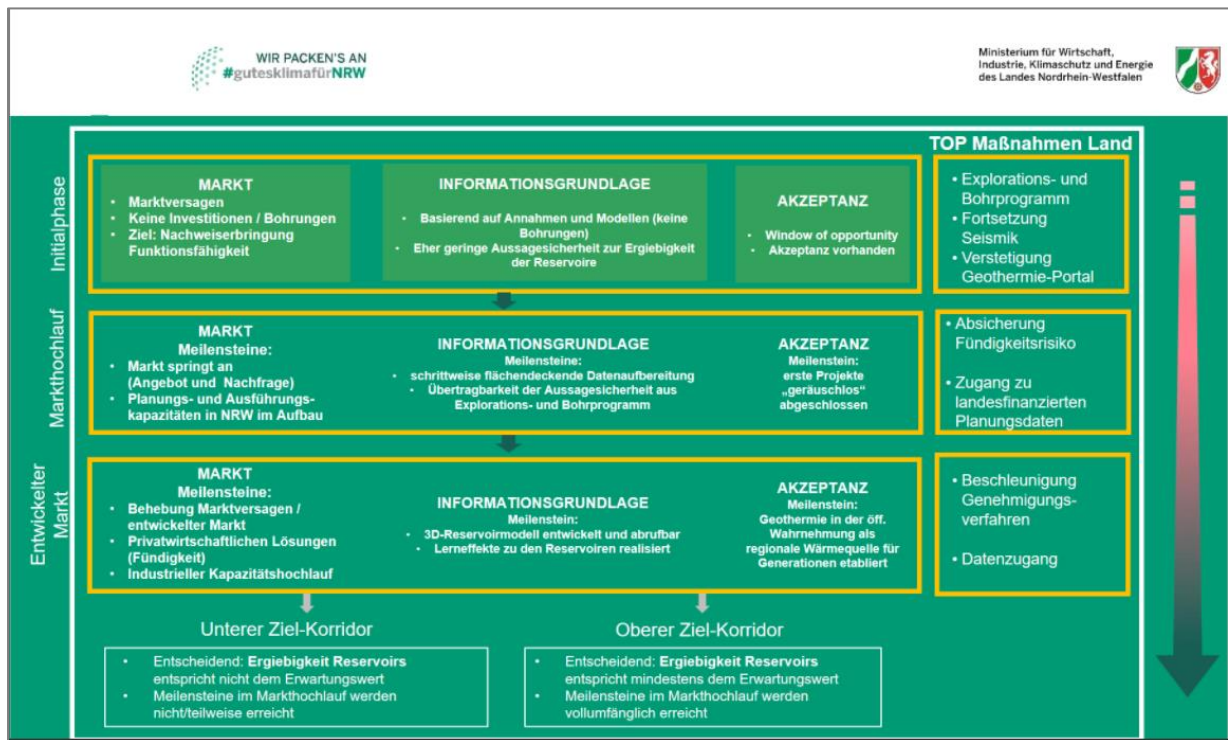

Figure 16: Market development (Ministerium für Wirtschaft, Industrie, Klimaschutz und Energie des Landes NRW, 2023)

Action fields:

- Masterplan as strategic leading paper from MWIKE (Ministerium für Wirtschaft, Industrie, Klimaschutz und Energie des Landes NRW)
- Data base (seismic) – planned investment: 65 Mio€
- Insurance (finding of an instrument, legal check ongoing)
- Acceleration (legal check for acceleration of approval process, enable process of acceleration for applicants and authorities).



Existing instruments:



Figure 17: Existing instruments (Ministerium für Wirtschaft, Industrie, Klimaschutz und Energie des Landes NRW, 2023)

Funding from idea until exploration



Figure 18: Funding from idea until exploration (Ministerium für Wirtschaft, Industrie, Klimaschutz und Energie des Landes NRW, 2023)

**Local example - Kabel Zero**

Why?

1. Expansion of renewable energies at the Hagen site of Kabel Premium Pulp & Paper
2. Reduction of greenhouse gas emissions, Reduction of fossil energies
3. Showcase project "Kabel ZERO" – unique in Europe
4. Sustainable paper production – Contribution to a future-proof site.

What?

1. Exploration and characterization of the underground
2. 2D seismic, core drilling, laboratory investigations
3. Integration of deep geothermal energy into the paper manufacturing process

Financing?

- State / federal state level finances well – in case of success the industry partner will pay the money and in dry hole case state / federal state carries the risk and no back-payment has to be made

Reference:

- Link - [Kabel Zero \(kabelpaper.de\)](http://kabelpaper.de)

#### 4.2.9.4 LEE (Landesverband Erneuerbare Energien) in Lower Saxony

Seed funding to secure the exploration risk, available in the short term from the economic development fund of the state of Lower Saxony

It must also be ensured that the stakeholders can make meaningful use of mining licenses; therefore, a usage concept must be reviewed before approval

Reference:

- Link - [LEE-Referent fordert Ansubfinanzierung für Geothermie-Projekte – Rundblick Niedersachsen \(rundblick-niedersachsen.de\)](http://rundblick-niedersachsen.de)

#### 4.2.9.5 Wärmewende durch Geothermie

This association of geothermal companies and municipal and private energy supply companies the aims for the quickest possible solution to supply urban regions CO2 neutral with heat:

Renewable Energy Act (EEG), Combined Heat and Power Act (KWK-Gesetz), and Rental Law Amendment Act considers geothermal energy insufficiently:

▪ **Much room for improvement to establish equal starting conditions:**

- Municipalities and businesses need economic conditions to advance the heat transition more efficiently and energy-saving

- Decision was made at the beginning of 2020 with the founding of the Fraunhofer Institute for Energy Infrastructures and Geothermal Energy (IEG). Essential components of the institute include the integration of the International Geothermal Center Bochum (GZB) into the Fraunhofer Society, as well as the establishment of two additional units for energy infrastructures in Cottbus and sector coupling in Jülich. The Fraunhofer IEG will also conduct research at branch offices in Aachen/Weisweiler and Zittau.

- COVID-19 pandemic teaches us: The foundation of our coexistence is autonomous, regional value creation. Deep geothermal energy IS autonomous, regional value creation – it makes us independent of energy imports from politically unstable regions.

▪ **Promotion of geothermal energy fundamentally makes sense in the following areas:**

- Research in the fields of geological reservoirs, exploration, and storage.
- Discovery fund to hedge the risk of discovery.

- "Even playground" for the construction and operation of geothermal plants.
- Support when private households switch from a previously fossil to a geothermally operated heating system.
- Promotion of network connections between geothermal heating plants and district heating networks and between district heating networks.

Reference:

- [Link - Wärmewende durch Geothermie – Wärmewende durch Geothermie \(waermewende-durch-geothermie.de\)](#)

#### 4.2.9.6 Rödl&Partner

External project support is very common especially for municipal utilities in Germany as described in the benchmark report. Rödl&Partner as a specialist on the financing sector described in a presentation during the Berliner Energietage 2023 (Rödl&Partner, 2023) several options for incentive systems and financing options that may be an option for the NL's and can be summarized as per below:

##### **General:**

- Predictability for medium and deep geothermal energy is present in some regions.

**Note MK:** Those are the "low hanging fruits" that need to be picked and where applicable geothermal projects utilized very quickly!

- Deep geothermal projects have extended implementation periods, high

equity needs, and repayment security upon confirmation of discovery.

- Regions lacking geological data face a "discovery risk," deterring developers and investors.
- Past solutions included private insurance and KfW Program 228, but no sufficient current solution exists in Germany
- Federal funding (BEW) since September 2022 subsidizes up to 40% of drilling costs, acting as "discovery insurance."

##### **Financing options:**

- Quick implementation, secure repayment, and low equity requirements make projects attractive to investors due to their return potential.
- Traditional organizational forms for incentives include private insurance, security funds, and public institutions.
- EU state aid law is central in developing incentive solutions to prevent competition distortions.
- Budgetary considerations and the amount of public funds are crucial in choosing incentive systems.
- Funding intensity and leverage (public funds per thermal capacity and their ratio to induced investments or CO2 savings) are additional criteria.
- National applicable mix of instruments must be found that also addresses areas currently not of interest to investors.

Overview:

1 Versicherung	Wahrscheinlichkeit / Höhe des Risikos wird benötigt.	Privater Sektor (Versicherungswirtschaft) und Finanzwirtschaft (z.B. KfW) zuständig.	Refinanzierung der Schäden und Kosten aus Einzahlungen von Prämien.
2 Zuschuss	Direkte Zahlung reduziert den Eigenkapitalbedarf.	Schnell wirksam bei Marktversagen: Beispiel <b>Breitband-Förderung</b> .	Projekte können nach Förderzusage begonnen werden. Kosten bei öffentlicher Hand.
3 Darlehen (Teilschulderlass oder Haftungsfreistellung)	Bis in die 2010er Jahre: KfW-Programm 228.	Darlehen muss bei Durchleitung über die Hausbank „besichert“ werden.	Keine bzw. verringerte Rückzahlung bei Nichtfälligkeit, Ausgleich durch öffentliche Hand.
4 Bürgschaft	Verpflichtung gegenüber dem Gläubiger eines Dritten, für die Erfüllung der Verbindlichkeiten.	Haushaltsrechtlich nur in <b>Ausnahmefällen</b> möglich (z.B. Hermes-Bürgschaften).	Nutzbar für bankübliche Darlehen. Zahlungen über öffentliche Hand.
5 Öffentlicher Fonds / Gesellschaft	Staatliche Stelle beauftragt Bohrunternehmen und veräußert erfolgreiche Doubletten.	Erste Ausstattung mit <b>staatlichen Mitteln</b> , Beihilferecht und Vergaberecht zu beachten.	Auch mit Beteiligung der Privatwirtschaft umsetzbar, dann ohne Vergaberecht aber mit Gewinnerzielung.

Figure 19: Anreizsysteme & Finanzierungslösungen (Rödl&Partner, 2023)

Financing options - a closer description & proposed solution:

**Establishment of a public company/fund that focuses on deep geothermal doublets nationwide.**

- Interested municipal utilities (Stadtwerke) / energy supply companies (EVU) could apply to the company through submissions. If the application is accepted, the public company will undertake the underground project development.
- Upon successful project development, the geothermal doublet will be

sold to the municipal utility or energy supply company. This way, the company achieves refinancing.

- In case of project failure, the municipal utility or energy supply company is not required to make any investment, as the boreholes belong to the public company as the project owner until the sale, and it bears responsibility, if necessary, until decommissioning.
- Advantages/Disadvantages (see below).

Advantages	Disadvantages
<p>Promotion of projects in various regions can be controlled by the government, leading to high project implementation numbers and a guaranteed market ramp-up.</p> <p>The public sector initially only makes an upfront investment, and funds are replenished through the sale of successful projects for "reinvestment."</p>	<p>High administrative effort and intensive entrepreneurial involvement of the public sector.</p> <p>Necessary upfront investments solely funded by public resources.</p> <p>To achieve market ramp-up, deposits with varying levels of knowledge and risk profiles must be promoted.</p>

Note:

Implementation with an equal share of private capital is possible; otherwise, clarification of EU state aid law is necessary. Classification within procurement law is also required.

#### 4.2.9.7 Fraunhofer / GFZ – Helmholtz-Zentrum Potsdam / KIT / Helmholtz Zentrum – Roadmap Tiefe Geothermie

Market potential of hydrothermal resources for district heating, industry, municipal heat, and housing sector is 300 TWh/a or 70 GW (> 25% of total heat demand), including surface geothermal, underground storage/mining water, and petro-thermal systems

The association of the institutes has defined a roadmap for the different sectors – politics, market, innovation & technology, capacity and acceptance (Fraunhofer, GFZ, KIT, UFZ, 2022). 5 key recommendations are defined within the roadmap:

1. Clear expansion goals must be defined and supported with regulatory measures.

2. Implement tools for risk mitigation, especially in terms of finance, exploration, and development programs.

3. Focus on key technologies such as drilling/reservoir methods (multilateral/EGS), borehole pumps, high-temperature heat pumps, development of large heat storage systems, and cross-sector system integration.

4. Activate the potential for value creation and job market growth.

5. Conduct extensive public outreach with proactive political support, placing municipalities at the center of communication with participatory opportunities.

Innovation and Technology (see chapter 6.3 of the Roadmap (Fraunhofer, GFZ, KIT, UFZ, 2022)):

1. Develop key technologies
2. Invest and set up demonstration projects
3. Infrastructure for research institutions
4. Digitalization
5. Exploration
6. Development
7. Generation and storage capacities
8. Technology transfer and capacity building
9. Maintenance & implementation of heat grid network
10. Personnel build up
11. Education
12. Foster acceptance

#### 4.2.9.8 LIAG

As per outcome of a cross impact analysis (see also Figure 20 & Figure 21) following key items have to be tagged to accelerate geothermal projects to realize the generation of 10TWh heat from deep geothermal projects by 2030:

- Availability of drilling rigs
- Economies of scale
- Knowledge transfer
- Communication
- Learning effects
- Promotion of first well
- Discovery insurance/fund
- Project development.



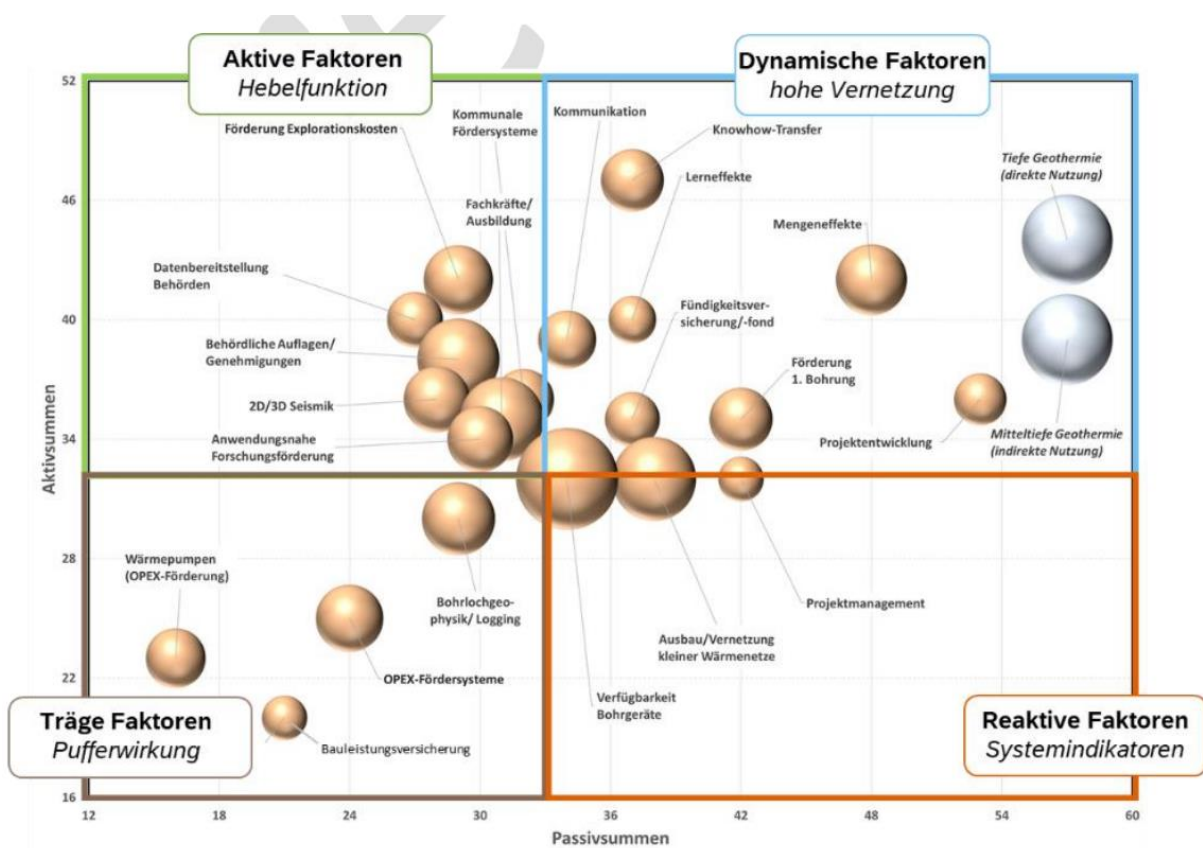

Figure 20: Ergebnis der Studie (Leibniz-Institut für Angewandte Geophysik (LIAG), 2013)

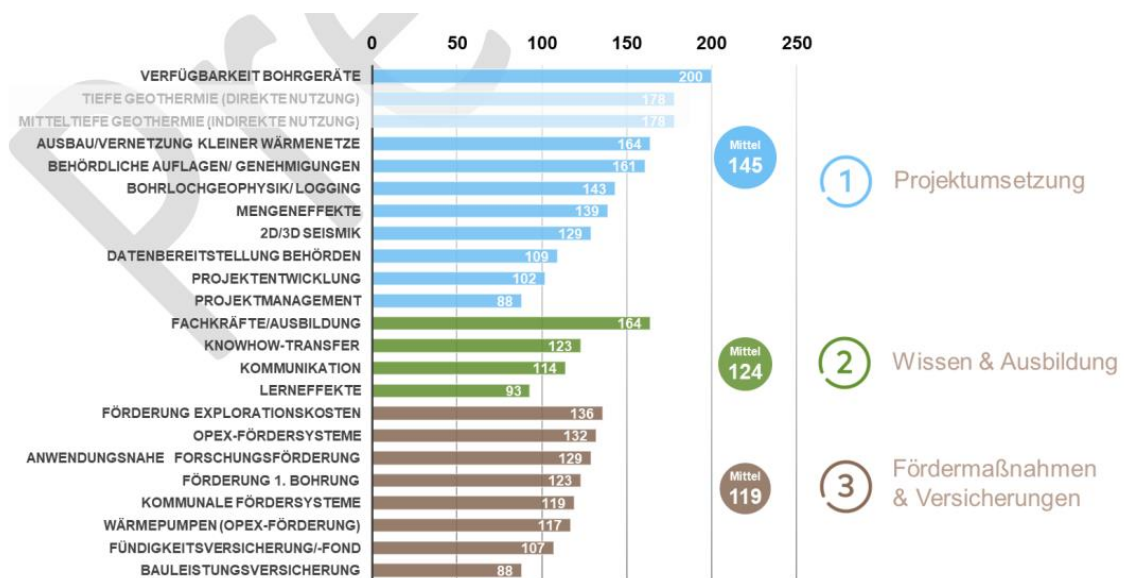

Figure 21: Sortierung der Relevanzsummen nach Cluster-Ranking (Leibniz-Institut für Angewandte Geophysik (LIAG), 2013)

#### 4.2.9.9 SWM

Experts from SWM recommend setting up a legislative framework for promoting geothermal energy projects, emphasizing their classification as being of "(paramount) public interest" due to their role in the energy transition, supply security, and crisis resilience. Key points include (SWM, 2022):

1. **Simplification of Approval Processes:** This involves streamlining the procedures for granting permissions, enabling early construction starts or preliminary decisions for geothermal projects (drilling sites, boreholes, facilities) and district heating pipelines. It also suggests insuring construction costs in case of a 'non-approval' scenario, similar to insuring the risk of non-discovery.

2. **Single Permit Requirement with Concentration Effect:** This proposes a bundled and controlled approach to managing individual permits and planning processes, including those related to mining, water, building laws, etc.

3. **Binding Approval Periods for Operational Plan Procedures:** This relates to construction of drilling sites and the drilling process itself, ensuring that these processes are carried out within specified timeframes.

4. **Right to a Scoping Meeting Before First Application:** This would clarify the fundamental eligibility for approval, aspects of the procedure, expected conditions, and involve relevant authorities early in the process.

5. **Standardization with mandatory eligibility for approval:** This would apply to

comprehensive projects, particularly for recurring technologies, substances, or designs, with individual case assessments being the exception rather than the rule.

6. **Privileging/Prioritizing Geothermal Projects in Building Law:** This would give geothermal energy projects a preferential status in the realm of construction and building laws.

7. **Regulation of the implementation of geothermal projects** in areas with protected characteristics (nature and species conservation, drinking water protection). Attempt to reconcile both "in harmony".

8. **Designation of suitability areas within the framework of land use planning/zoning procedures** for renewable energy/geothermal; Establishment of a "heat transition" area quota.

9. **Exemption from existing obligations under UVPG** (up to 12 months in duration), including the removal of the limit of 10 million m<sup>3</sup>/year for circulation; previously mandatory environmental impact assessment in case of anticipated exceedance.

10. **Possibility for an abbreviated SAP** (Special Species Conservation Assessment).

11. **Establishment of permitability for a collection line** for multi-well operation (optimizing continuity and flexibility of geothermal operations).

#### 4.2.10 Key lessons learnt from Germany to replicate in the Netherlands

Following table outlines the key learnings we consider to be valuable for the acceleration process with the Netherlands:

Table 3: Key learnings - Germany

<b>Consortium of municipalities/alliances to develop a heatnet</b>
<b>National roadmap with 2030 and 2040 targets / “Nationale Erdwärmekampagne”</b>
<ul style="list-style-type: none"> <li>- Roadmap of Fraunhofer institute (Fraunhofer, GFZ, KIT, UFZ, 2022) (p. 35 ff)</li> <li>- Federal Ministry of Economic Affairs and Climate Action (BMWK - Deep geothermal energy)             <ul style="list-style-type: none"> <li>o Aim of ministry to better use of geothermal energy – set up of “Eckpunkte-Papier” / Key point paper (BMWK, 2022):                 <ul style="list-style-type: none"> <li>▪ Exchange with actors – Dialogue process for necessary measures.</li> <li>▪ Data campaign – Systematic provision of existing data to enable the foundation for successful projects.</li> <li>▪ Exploration campaign – Federal government co-funded exploration in areas with a high probability of success for concrete projects.</li> <li>▪ Acceleration of planning – Identify and exploit optimization potentials in approval processes.</li> <li>▪ Funding programs – Impulses for market preparation and competitiveness.</li> <li>▪ Risk mitigation – Examination of risk hedging instruments.</li> <li>▪ Skilled workforce security – Development of strategies for recruiting young talent.</li> <li>▪ Acceptance – Information events and acceptance programs should become an integral part of every project.</li> </ul> </li> </ul> </li> <li>- “Bundesverband Geothermie” as strong pusher             <ul style="list-style-type: none"> <li>o Organization of Stadtwerke workshops</li> <li>o i.e push (Bundesverband Geothermie, 2023)                 <ul style="list-style-type: none"> <li>▪ that BauGB (Federal Building Code) is to undergo a comprehensive amendment. Federal government will create a special privilege for geothermal energy (deep drilling, above-ground facilities, and grid connection) in the level of land-use planning by amending § 35 para. 1 of the BauGB.</li> <li>▪ this action responds to the long-standing demand of the Federal Association of Geothermal Energy (BVG) for equal treatment of geothermal energy with other already privileged renewable energies.</li> <li>▪ to assign during spatial planning, designated suitable areas for geothermal projects where simplified permitting requirements apply.</li> </ul> </li> <li>o Push for higher funding i.e. for the 8. Energieforschungsprogramm &amp; recommendations for R&amp;D (Bundesverband Geothermie, 2023)</li> </ul> </li> </ul>
<b>Guideline for the development and execution of deep geothermal projects</b>
<ul style="list-style-type: none"> <li>- i.e. Lotse für Tiefengeothermie-Projekte in Niedersachsen fr. Landesamt für Bergbau, Energie und Geologie in Niedersachsen</li> </ul>
<b>Cities - decarbonizing planning</b>
<ul style="list-style-type: none"> <li>- i.e. law for decarbonization of heat nets (example Munich/SWM)</li> </ul>
<b>Cogeneration plants</b>
<ul style="list-style-type: none"> <li>- i.e. heating/cooling and electricity</li> </ul>
<b>Co-mining - Lithium extraction</b>
<b>Closed loop - advanced geothermal systems for heat (&amp; power)</b>

<b>General supporting scheme (see BVG interview) &amp; especially role of KfW supporting geothermal</b>																																								
<b>Acceleration and financial support</b>																																								
- NRW example (i.e. Seismic campaign, Hagen – KabelZero)																																								
<b>Law for necessity of “heat planning” (Wärmeplanung)</b>																																								
<b>Mapping – geothermal heating potential, need for heat and optimization of heat nets, Location-specific development of potential and economic feasibility analysis</b>																																								
<b>Low temp wells – high-performance heat pumps utilization for district heating -&gt; example for a demonstration project</b>																																								
- i.e. Schwerin (56°C) -> w/ heat pump: 80°C - i.e. Hamburg (48°C) -> w/ heat pump: 70°C - i.e. Bochum test w/ heat pump: up to 120°C																																								
<b>CO2 prevention/phase-out incentive system</b>																																								
<b>Improvement of deep geothermal heat systems</b>																																								
- i.e. hybrid storage integration																																								
<b>Digitalization</b>																																								
- Intelligent control of net (supply / demand) - Digital twins																																								
<b>Utilize acceptance for renewable energy / particularly geothermal</b>																																								
- Energieeffizienzlabel der Europäischen Kommission (UBA 2016b) - European Energy Award - label “Europäische Energie- und Klimaschutzkommune“ (Graben-Neudorf wird als Klimaschutzgemeinde ausgezeichnet (bnn.de))																																								
<b>Promote industry projects</b>																																								
- i.e. KabelZero project - NRW - i.e. MTU – Bavaria																																								
<b>Acting options for operators - financial instruments</b>																																								
<p style="text-align: center;"><b>Optionen für Finanzierungsinstrumente</b></p> <table border="1" style="width: 100%; border-collapse: collapse;"> <thead> <tr> <th style="width: 25%; text-align: center;">Kreditmarkt</th> <th colspan="2" style="width: 50%; text-align: center;">Kapitalmarkt</th> <th style="width: 25%; text-align: center;">Ergänzend</th> </tr> </thead> <tbody> <tr> <td style="text-align: center;">Kredit Hausbank</td> <td style="text-align: center;">Schuldscheindarlehen</td> <td style="text-align: center;">Kapitalerhöhungen</td> <td style="text-align: center;">Sale &amp; lease back</td> </tr> <tr> <td style="text-align: center;">Verpfändung zukünftiger Einnahmen/EBITDA</td> <td style="text-align: center;">Wandelanleihen</td> <td style="text-align: center;">Verpfändung von Unternehmensanteilen</td> <td style="text-align: center;">Zweckgesellschaften für den Erwerb von Unternehmen</td> </tr> <tr> <td style="text-align: center;">Bausicherheiten</td> <td style="text-align: center;">Verbriefte Forderungen</td> <td style="text-align: center;">Ertragsanleihen</td> <td style="text-align: center;">Versicherungsvertrag</td> </tr> <tr> <td></td> <td></td> <td></td> <td style="text-align: center;">Fremdfinanzierte Übernahmen</td> </tr> <tr> <td></td> <td></td> <td></td> <td style="text-align: center;">Weitere Verhandlungen</td> </tr> <tr> <td style="border: 1px dashed gray; text-align: center;">Sustainability-linked Kredite</td> <td style="border: 1px dashed gray; text-align: center;">Grüne Anleihen</td> <td style="border: 1px dashed gray; text-align: center;">Grüne/nachhaltigkeitsorientierte Derivate</td> <td style="border: 1px dashed gray; text-align: center;">Partnerschaften/ Joint Ventures</td> </tr> <tr> <td style="border: 1px dashed gray; text-align: center;">Unternehmensbürgschaft</td> <td style="border: 1px dashed gray; text-align: center;">Konventionelle Anleihen</td> <td style="border: 1px dashed gray; text-align: center;">Asset-backed Commercial Paper</td> <td></td> </tr> <tr> <td style="border: 1px dashed gray; text-align: center;">Kreditbriefe</td> <td style="border: 1px dashed gray; text-align: center;">Sustainability-linked Anleihen</td> <td style="border: 1px dashed gray; text-align: center;">Asset-backed Securities</td> <td></td> </tr> <tr> <td style="border: 1px dashed gray; text-align: center;">Bankbürgschaft</td> <td style="border: 1px dashed gray; text-align: center;">Hybride Wertpapiere</td> <td style="border: 1px dashed gray; text-align: center;">Staatliche/institutionelle Unterstützung</td> <td style="text-align: center;">☐ Blended-Finance-Option</td> </tr> </tbody> </table> <p style="text-align: right; font-size: small;">Ohne Anspruch auf Vollständigkeit</p>	Kreditmarkt	Kapitalmarkt		Ergänzend	Kredit Hausbank	Schuldscheindarlehen	Kapitalerhöhungen	Sale & lease back	Verpfändung zukünftiger Einnahmen/EBITDA	Wandelanleihen	Verpfändung von Unternehmensanteilen	Zweckgesellschaften für den Erwerb von Unternehmen	Bausicherheiten	Verbriefte Forderungen	Ertragsanleihen	Versicherungsvertrag				Fremdfinanzierte Übernahmen				Weitere Verhandlungen	Sustainability-linked Kredite	Grüne Anleihen	Grüne/nachhaltigkeitsorientierte Derivate	Partnerschaften/ Joint Ventures	Unternehmensbürgschaft	Konventionelle Anleihen	Asset-backed Commercial Paper		Kreditbriefe	Sustainability-linked Anleihen	Asset-backed Securities		Bankbürgschaft	Hybride Wertpapiere	Staatliche/institutionelle Unterstützung	☐ Blended-Finance-Option
Kreditmarkt	Kapitalmarkt		Ergänzend																																					
Kredit Hausbank	Schuldscheindarlehen	Kapitalerhöhungen	Sale & lease back																																					
Verpfändung zukünftiger Einnahmen/EBITDA	Wandelanleihen	Verpfändung von Unternehmensanteilen	Zweckgesellschaften für den Erwerb von Unternehmen																																					
Bausicherheiten	Verbriefte Forderungen	Ertragsanleihen	Versicherungsvertrag																																					
			Fremdfinanzierte Übernahmen																																					
			Weitere Verhandlungen																																					
Sustainability-linked Kredite	Grüne Anleihen	Grüne/nachhaltigkeitsorientierte Derivate	Partnerschaften/ Joint Ventures																																					
Unternehmensbürgschaft	Konventionelle Anleihen	Asset-backed Commercial Paper																																						
Kreditbriefe	Sustainability-linked Anleihen	Asset-backed Securities																																						
Bankbürgschaft	Hybride Wertpapiere	Staatliche/institutionelle Unterstützung	☐ Blended-Finance-Option																																					
<b>Figure 22: Optionen für Finanzierungsinstrumente (BDEW, VKU, Deloitte, 2023)</b>																																								



# Denmark





### 4.3 Denmark

#### 4.3.1 General / Current status

Deep geothermal energy development in Denmark is starting to gain momentum, with several large heating and cooling geothermal projects in the pipeline and the potential to significantly contribute to the country's renewable energy mix.

Denmark is experienced in the energy transition since late 1970. Carbon pricing has been applied through European Emissions Trading Scheme + national CO2e tax. Result - in 2022 60% of electricity

from wind & solar. In 2030 >100% is expected.

Transforming energy systems in Denmark has been a combination of technology & infrastructure. It has shown to be essential to have stable policies to mitigate risks. An interesting case study of how an energy utility can transition from fossil fuels to renewable energy and the enabling regulatory framework that made it possible is valuable to work through (see Figure 23).

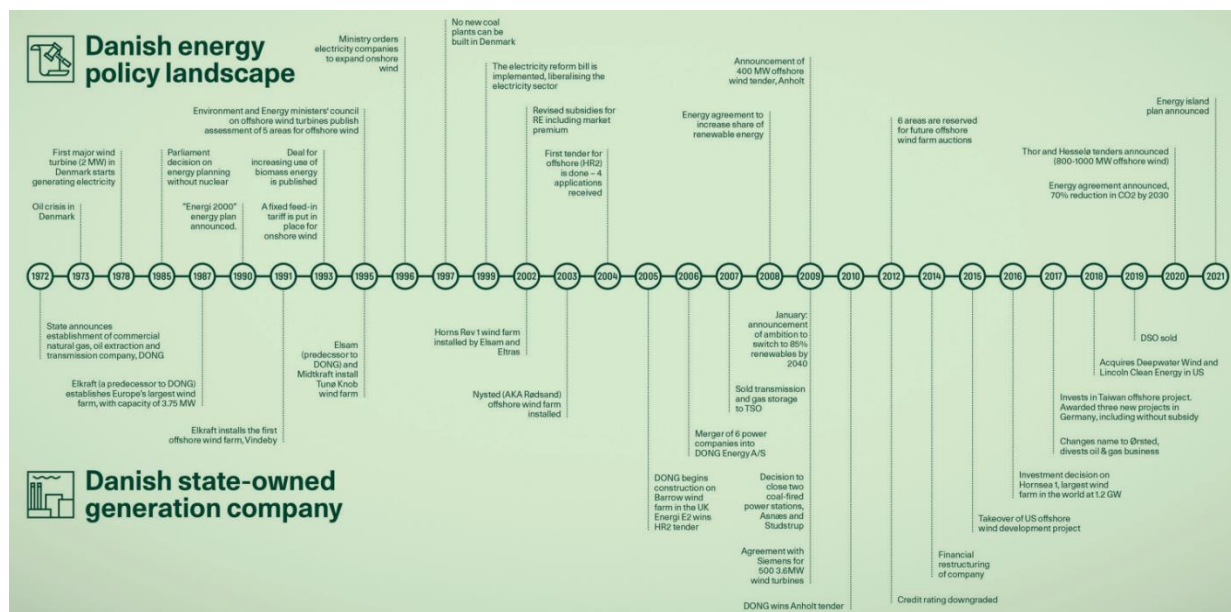

Figure 23: Timeline - The Danish renewable energy journey - Key milestones in Denmark and Ørsted's transition to green energy (State of Green, 2021)

Denmark's massive goal to go from 9 GW (wind & solar) in 2021 to 32GW (renewables) in 2030 reduce emissions by 70%, creates jobs and boosts the economy. It includes Power-to-X strategy in order to deal with excess wind power.

Denmark gets from NIMBY to YIMBY ('Yes in my backyard!') through a cooperation with locals and a large energy company in Kemvig Municipality regarding a 50 MWh solar plant. This sparked ~M€10 investment from participating citizens within a 4.5 km radius. In the Netherlands cooperations are popular as well: 705 energy cooperations in 2023, totaling 315MW wind and 272MW

solar installed (energie samen, 2024) (combined output ~150MWh), involving 120,000 citizens, who invested on average ~€2,000. The difference is that Dutch cooperations are initiatives from citizens themselves, whereas in Denmark it is policy.

Currently, three geothermal powered heat nets or District Heating (DH) systems are in operation: Thisted since 1984 (7 MWth), Copenhagen Margretheholm since 2005 (14 MWth) and Sønderborg since 2013 (13 MWth). 6 projects are under development, for three of them the permit is already granted, and the exploration started.

### 4.3.1.1 Key Developments

For geothermal energy, Denmark has a favourable sub-surface and well-developed heat nets. Therefore, many projects were started 10 to 15 years ago. However, the failure of the construction of the Viborg Geothermal wells in 2012 lead to a major halt of all geothermal projects in development in Denmark (CPH post, 2014).

The Danish government has taken proactive steps to support geothermal energy, particularly for district heating. In 2020, they announced the establishment of

a geothermal task force to analyze the socio-economic potential of geothermal heat in district heating and to develop a state aid model to support its cost-effective development. This initiative is part of a broader economic stimulus package focusing on clean energy technologies, reflecting the government's commitment to advancing geothermal energy in Denmark.

A clear entry strategy for renewable energy and exit strategy for fossil fuels has been set up:

**Table 4: Examples of entry and exit strategies for energy companies, as experienced in Denmark over the last 10-15 years in particular (State of Green, 2021)**

	Entry strategy for renewable energy	Exit strategy for fossil fuels
Human resources	Cultural shift within the company. Build up human resources: harvest internal resources, retrain personnel, create synergies with existing base and attract new talents, increasing sustainable job opportunities.	Divest businesses that do not align with the new green vision
Technology strategy	Develop and test proof of concept projects, devise long term strategies with ambitious targets and scale up large-scale renewable projects. Then choose technologies based on their return and risk profile in a given regulatory framework, investigating the impact on players in the supply chain. Bring the technology to cost-competitive levels with the existing products, assessing the role of the new product in existing and new markets.	Convert directly, e.g., coal to biomass  The same could be done with existing coal power plants, by using the land for hybrid solar and wind projects and re-using the existing transmission infrastructure.
Market forces & project choices	Invest in new projects.  Joint ventures can be a good way to gain technical experience and knowledge, filling the gap with the missing technical competences to reach the objective. Institutional, national and international investors can be attracted to green projects with long-term returns and low risk. Investors and technical advisors which have been educated about the new technology and the mission are more likely to feel confident in approving co-investments.	Abandon projects  Several coal-fired power plants have been abandoned in northern Europe as they are no longer profitable and attract public opposition.

In March 2023, the Danish Parliament approved a new law that simplifies the regulatory framework for deep geothermal projects, paving the way for the construction of large-scale geothermal plants. In terms of policy and regulation, Denmark's approach to geothermal energy is characterized by recent changes like the lifting of price regulations for geothermal heat supply. This allows for more flexible pricing agreements between district heating companies and geothermal operators, with a cost ceiling for consumers. Such regulatory changes aim to foster a more conducive environment for geothermal development.

The Danish city of Aarhus is expected to host the country's first large-scale geothermal project, developed by Innargi (founded by A.P.Møller Holding). The project aims to supply up to 20% of the city's district heating demand with geothermal energy.

The Geological Survey of Denmark and Greenland (GEUS) research to assess the country's geothermal resources and identify potential sites for development. A first mapping of the potential geothermal reservoirs in Denmark was done in 1980. GEUS published a report on the potential in 1998 as part of the EU geothermal atlas. An update was done in 2009. GEUS published a webGIS portal in 2016.

#### 4.3.1.2 Challenges and Opportunities

While Denmark has significant geothermal potential, accurately assessing the resource base is crucial for successful project development.

The high capital cost of deep geothermal projects in such a juvenile market is a challenge, but government support and

innovative financing mechanisms can help overcome this barrier.

Deep geothermal energy can play a crucial role in decarbonizing Denmark's heating sector and achieving the country's ambitious climate goals. 66 % of the population is heated by DH: the source is largely coming from bio-energy, but also coal, oil & peat, fossil gas and non-biodegradable waste.

#### 4.3.1.3 District heating

District heating exists longer than sustainable energy as an efficient way of heating. Today, it turns out to be very helpful in the energy transition as it is flexible to adopt all kinds of excess heat (power plants, industry) and renewable sources. Even excess electricity from wind and solar are being used in district heating systems in Denmark. 98% of Copenhagen buildings are connected. Key is to focus on TCO. Efficiency optimization happens currently by adjusting to lower temperatures. Since the early eighties there is national heat planning in Denmark, since early nineties subsidies on renewable energy. The importance of the Heat Supply Act here shouldn't be underestimated, a law that regulates district heating in Denmark (as well as any other initiative regarding heating).

District heating dates back to 1903. 1970: 30% of homes connected. Currently 63% (Germany 14%) – these are approximately two thirds of Danish households which are connected to a district heating system, with more than half of the systems in the country being based on renewable energy sources and efficient industrial heat pumps (Fournier, 2024).

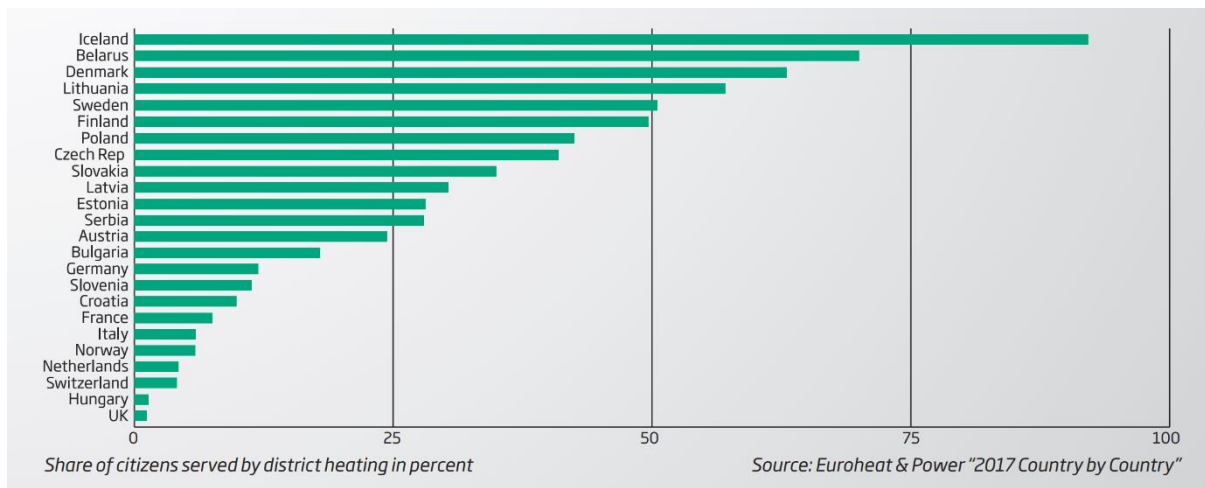

Figure 24: Share of citizens served by district heating in percent (Euroheat & Power, 2017)

Heat planning laws have been crucial. Currently the 2030 target is 70% CO2 reduction compared to 1990 and 100% renewable district heating, 100% electricity from wind. Total fossil independence should be reached in 2050.

The is equal price determining across all districts, this means that price differences occur. Heat supply companies must be not-for-profit by law.

Cost of the heat network is part of the price of the heat is it is owned by the heat supplying company. Efficiency is a focus. Currently in Copenhagen 85% of produced heat is being sold. Efficiency increases with lower temperatures. This requires insulated buildings. Heat supply has come down from 110°C in the sixties to 55°C today in 4<sup>th</sup> generation district heating. This goes in line with (Fournier, 2024) explaining that the outlook for Denmark's renewable energy progress seems to be tending towards the incorporation of low-temperature district heating systems. These DH systems are able to operate with supply temperatures of between 50°C and 70°C bringing in two advantages: to minimize heat losses, as there is a smaller temperature difference, and the use of low-grade heat sources, including some of the renewable source."

Heating and cooling buildings account for 40-50% of all energy used in Europe & globally. Research (State of green, 2016) show that District Heating is essential in cost

effectiveness, flexibility and renewability of energy.

#### 4.3.1.4 Heat in the area of Copenhagen

Main considerations are:

- Existence of an integrated heat provision systems with different operators,
- Market oriented control to feed in heat into a heat pool,
- Decarbonization of the heat provision in bigger cities.

According to (Radloff, 2015) in the Greater Copenhagen area, around 1 million people are supplied with heat through a connected heating network by 24 district heating companies. The heat is provided from both central and decentralized facilities. In total, this amounts to a heat demand coverage of over 9.5 million MWh per year, which corresponds to almost 20% of the entire Danish district heating demand.

As a result of the (mandatory) municipal heat planning, Copenhagen and 4 surrounding municipalities founded DH company CTR in 1984, and 12 municipalities in the Greater Copenhagen area established DH company VEKS. Their task is to connect the existing heat networks in the member municipalities through a heat transport network, to create the conditions for balancing heat demand



coverage, and to promote the expansion of heat networks in the member municipalities.

CTR, VEKS, and the Copenhagen municipal steam network operator HOFOR created a joint control facility, varmelast.dk, in 2008. This facility aims for continuous economic optimization of all plants, taking into account all economic framework

conditions (electricity market, fuel costs, energy taxes, etc.). Priority is given to waste incineration plants over CHP plants. On this basis, an economically optimal distribution of the load for electricity and heat production in the Greater Copenhagen area is established under the conditions of liberalization, depending on the current production costs.

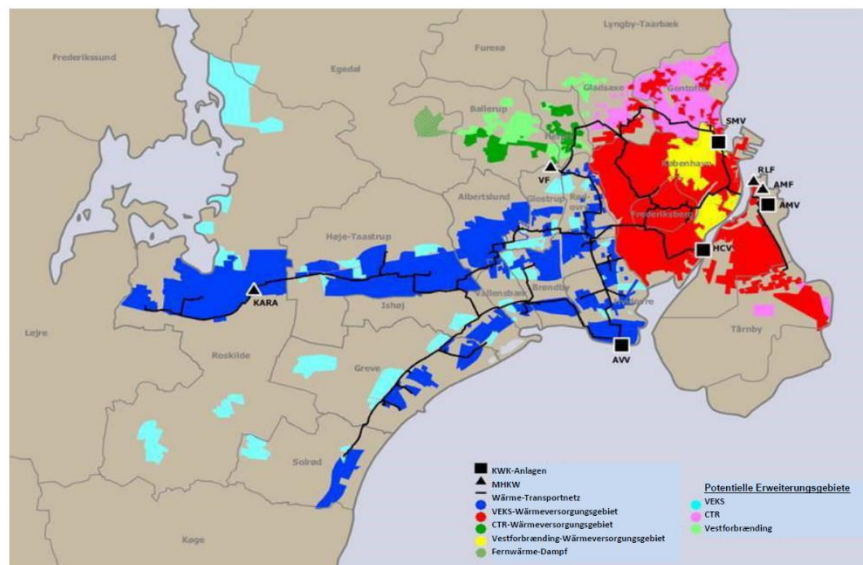

Figure 25: Heating network areas in the Greater Copenhagen area connected by transport networks (as well as potential expansion areas - here still without Køge, which would extend from Solrød to the south) (Radloff, 2015)

#### 4.3.1.5 Viborg failed geothermal project

Viborg district heating company had the intention to establish the largest geothermal plant in Europe with 8 wells in 2012 and supply Viborg's district heating consumers with green, renewable energy from geothermal energy. The Viborg District Heating became operator and licensee of the planned Kvals-2 and Kvals-3 near the exploration well Kvals-1.

Drilling started in January 2012 but was stopped due to the operator running into liquidity problems because of several incidents while drilling. (Shareholder) Viborg Municipality took over the project which was finally stopped in June 2012. Although no geothermal heat is produced, the incurred costs are accounted to the heat net users,

resulting in a higher fee. Court cases and various investigations followed and the main causes were the lack of technical and financial skills and leadership as available data from the adjacent Kvals-1 well was not used what resulted in an incorrect well design and mud program. The Viborg heat net is now switching from gas to bio-gas, electric boilers and heat pumps (Energy Supply, 2017).

This bad experience had a negative effect for the geothermal sector in Denmark, with no development for 5 years. Some actors have also reported that the Danish risk mitigation scheme has also incentive bad project development.



---

#### 4.3.1.6 Overall Outlook

Deep geothermal energy is poised to become a significant part of Denmark's renewable energy portfolio. With government support, technological advancements, and continued research, Denmark is well-positioned to harness the vast geothermal resources beneath its soil.

A global level playing field is to be desired – EU Taxonomy and CRSD where companies report emissions.

Future development will likely focus on large-scale geothermal plants that can serve multiple district heating systems and integrate with other renewable energy sources. As deep geothermal technology matures and costs decline, Denmark will be closer to realizing its full potential as a geothermal energy superpower.

#### 4.3.2 Financial instruments / financing the green transition

Denmark does not provide any specific support scheme for geothermal electricity or heating and cooling. Nevertheless, heat pumps may benefit from the reduced tax on electrical heating adopted in 2018 (152 DKK/kWh from the previous 307 DKK/kWh).

Danish government formed climate partnerships across the economy including the financial industry, to come up with recommendations. For finance, they were:

1. Long term and predictable finance back-up by state loan funds
2. Financing R&D on sustainability and export of it
3. Data transparency, uniformity in measuring CO2 impact on investments
4. Public sector as early adopter
5. Engage public funding / guarantees to attract private finance
6. Reducing administrative burden.

Research work has been funded by the Danish council for strategic research and the Innovation Fund Denmark (EGEC, 2021).

Furthermore, in 2017 Denmark introduced a new scheme to provide financial risk coverage in connection with geothermal drilling, subsequently extended until 2024. Companies with geothermal permits can also apply for coverage by the scheme, which they must pay for themselves. As per (Richter, 2022) Dansk Fjernvarme hopes that the new price regulation model that has been introduced in December 2021 could bring a further push:

*The Heat Supply Act's substitution price principle did not provide enough security for geothermal plant owners and operators, who typically make large investments. A new checklist model is being proposed, which takes into account consumer protection through a price ceiling, efficiency gains sharing, and approval and supervision by the Danish Supply Agency. While the previous model is still in place, the new checklist model is preferred for its flexibility and consumer protection. However, for district heating companies to become more active in geothermal plant establishment and operation, the national guarantee scheme for geothermal wells needs to be strengthened significantly. Additionally, the regulation should consider the natural monopoly nature of district heating supply when granting exclusive rights.*

Danish pension funds are pushing for sustainability. The financial sector measures CO2 footprint of loans and investments. Financial incentives on mortgages if sustainable investments are made.

The Danish Investment Fund for Developing Countries played a key role in several investments in other countries, using Danish (wind turbine and district heating) technologies. Additionally Danish fund management adds to the reduced risk for investors.

---

### 4.3.3 Governance

Denmark's policy shows an integrated approach, including climate adaptation, helping biodiversity, protecting the Amazon and the oceans and investing in developing countries. Multinationals and pension funds are involved.

Danish government pursues bilateral partnerships with other countries around the globe to develop investment opportunities with reduced risks, on the basis of Danish knowledge and experience.

The governance for deep geothermal projects in Denmark is a complex and evolving landscape, as the country seeks to harness the vast potential of this renewable energy source. The regulatory framework is still being developed, and there are a number of different authorities involved in the licensing and permitting process.

#### 4.3.3.1 Regulatory Overview

The Danish Energy Agency (DEA) is the primary regulatory body for deep geothermal projects. The DEA is responsible for issuing permits for drilling, exploration, and production of geothermal energy. The agency also has a role in monitoring the environmental impact of deep geothermal projects.

- Website: [Energistyrelsen | \(ens.dk\)](https://www.energistyrelsen.dk)
- Goal: well-planned green transition with Denmark leading the way, sharing Danish experiences and solutions globally

In addition to the DEA, a number of other authorities may be involved in the governance of deep geothermal projects. These include:

- **The Danish Ministry of Climate, Energy and Utilities:** Ministry is responsible for national and international

efforts to prevent climate change. Through visionary green leadership we aim to achieve the Danish Government's target to reduce Danish greenhouse gas emissions by 70 percent by 2030.

- **The Geological Survey of Denmark and Greenland (GEUS):** GEUS is responsible for conducting geological surveys and providing information on geothermal resources.

- **The Danish Environmental Protection Agency (DEPA):** DEPA is responsible for protecting the environment from pollution and other harmful effects.

- **The Danish Maritime Authority:** The Danish Maritime Authority is responsible for regulating activities in the marine environment.

- **The Danish Utility Regulator (DUR):** Is responsible to maintain a strong and effective supervision of the utility sectors – electricity, natural gas and district heating. Purpose is to secure consumer interests in the utility sectors by striving for a higher level of efficiency, the lowest possible costs in the short and long term, a stable and secure supply, and a cost-effective development in technology and climate-friendly initiatives.

#### 4.3.3.2 Licensing and Permitting Process

The licensing and permitting process for deep geothermal projects in Denmark can be lengthy and complex. The process typically involves the following steps:

▪ **Pre-application consultation:** The developer of a deep geothermal project must

first consult with the DEA and other relevant authorities to discuss the proposed project and address any potential environmental concerns.

- Application for pre-assessment: The developer must then submit an application for pre-assessment to the DEA. This application includes information about the proposed project, the geological conditions, and the environmental impact.

- Pre-assessment decision: The DEA will review the pre-assessment application and make a decision on whether the project should proceed to the next stage of the permitting process.

- Application for environmental approval: If the DEA approves the pre-assessment, the developer must then submit an application for environmental approval to the DEPA. This application includes more detailed information about the project, including the proposed drilling plan, the waste management plan, and the monitoring plan.

- Environmental permit: The DEPA will review the environmental approval application and make a decision on whether to issue a permit.

- Application for drilling permit: If the DEPA issues an environmental permit, the developer can then submit an application for a drilling permit to the DEA. The drilling permit is required to drill the wells for the geothermal project.

- Drilling permit: The DEA will review the drilling permit application and make a decision on whether to issue a permit.

- Application for production permit: Once the drilling is complete, the developer can submit an application for a production permit to the DEA. The production permit is

required to extract geothermal fluids from the wells.

- Production permit: The DEA will review the production permit application and make a decision on whether to issue a permit.

#### 4.3.3.3 Challenges and Opportunities

The governance of deep geothermal projects in Denmark is a challenging task especially after the Viborg project. However, there are also significant opportunities for Denmark to develop a large-scale geothermal industry that can help to reduce the country's reliance on fossil fuels.

The Danish government is committed to promote deep geothermal energy as a renewable energy source. The government has set a target of generating 10% of Denmark's electricity from geothermal sources by 2030.

The government is also providing financial support for deep geothermal projects. In 2023, the government awarded a €20 million grant to a project to develop a deep geothermal district heating system in Aarhus, Denmark.

The development of deep geothermal energy in Denmark is still in its early stages, but the country has the potential to become a leader in this field. With the right support from the government and the private sector, Denmark can harness the vast potential of deep geothermal energy to create a cleaner and more sustainable energy future.

Innargi (founded in 2017) is today owned by A.P. Moller Holding, ATP (Denmark's largest pension fund), NRGi, and Sampension and brings in a lot of technical and financial strength partly from the previously by Moller Holding owned Maersk Oil company. Innargi delivers heat to the local heatnets using long term (30 years) contracts. Innargi takes all risk and cost of the initial exploration phase and uses drilling campaigns of 14 wells or more to reduce drilling costs.

---

#### 4.3.4 Social acceptance

The social acceptance of geothermal energy in Denmark is multifaceted, influenced by a range of factors including governance, project organization and processes, and local municipality perspectives. While specific studies on Denmark in this context are not as extensive as in countries like Germany or France, the growing interest and development in geothermal energy indicate a positive trend towards its acceptance and integration.

Even though there is not much information available on the reputation impact of the Viborg project which failed with unproductive wells and ended up for district heating customers with a bill of about DKK 150 million. It can be assumed that this led to a closer analysis of the geothermal strategy and the way of developing projects like this.

Overall, while the social acceptance of geothermal energy in Denmark is growing, it is influenced by a combination of policy decisions, regulatory frameworks, technological advancements, and public and private sector dynamics. Studies have consistently demonstrated a favorable attitude towards geothermal energy among the Danish public. A 2017 survey conducted by the Danish Energy Agency revealed that 60% of Danes supported the development of geothermal energy for electricity generation, while 72% favored its utilization for district heating purposes. This widespread support reflects the growing recognition of geothermal energy's potential to contribute to a sustainable energy future (Danish Energy Agency, 2017). The country's commitment to a sustainable and carbon-neutral future, along with the recognized potential of geothermal resources, positions it well for increased utilization of this renewable energy source.

##### 4.3.4.1 Positive Aspects

The social acceptance of geothermal energy in Denmark showcases several positive aspects:

- Environmental Awareness: Denmark's embrace of geothermal energy reflects a strong societal commitment to environmental sustainability. This acceptance indicates a widespread understanding of the importance of reducing carbon emissions and combating climate change.

- Energy security: By investing in geothermal energy, Denmark reduces its dependence on imported fossil fuels, enhancing its energy security. This is especially crucial given the global volatility in energy markets.

- Economic benefits: The development of geothermal resources can stimulate local economies. It creates jobs not only in the construction and operation of geothermal plants but also in ancillary industries. Moreover, the stable pricing of geothermal energy can provide economic predictability for businesses and consumers.

- Innovation and leadership: Denmark's adoption of geothermal energy solidifies its position as a leader in renewable energy and innovation. This leadership can inspire other nations to follow suit, amplifying the global impact of sustainable energy practices.

- Community Involvement: The social acceptance often involves community participation in decision-making processes, leading to more democratic and locally adapted energy solutions. This can increase the sense of ownership and responsibility towards sustainable development.

- Educational opportunities: The focus on geothermal energy provides educational and research opportunities. It encourages universities and research institutions to delve into geothermal technology,

---

potentially leading to advancements and increased efficiency.

- Health and quality of life improvements: By reducing reliance on fossil fuels, geothermal energy contributes to cleaner air and a healthier environment. This can have a direct positive impact on public health and overall quality of life.

- Cultural shift towards sustainability: Embracing geothermal energy reflects a broader cultural shift towards sustainability and responsible resource use. It demonstrates a societal commitment to preserving the environment for future generations.

- Resilience Against Climate Change: By adopting renewable energy sources like geothermal, Denmark enhances its resilience against the impacts of climate change, setting a sustainable path for energy consumption.

- Global Influence: Denmark's success especially with the heat net and the hopefully combination with geothermal can serve as a model for other countries, especially those with similar geographical and climatic conditions, fostering global collaboration in the pursuit of sustainable energy solutions.

- Heat nets: heat nets, as pre-requisite for geothermal heating, are well-accepted in Denmark.

#### 4.3.4.2 Negative Aspects

The social acceptance of deep geothermal energy in Denmark, like in many countries, is a complex issue that can be influenced by various factors. While deep geothermal energy offers a sustainable and low-carbon energy source, there are certain negative aspects associated with its social acceptance. Here are some of the key concerns that have been raised:

-

- Visual impact: Deep geothermal plants require drilling rigs and production buildings, which can be visually intrusive in scenic areas. This is particularly relevant in Denmark, where a strong focus is placed on preserving natural beauty and cultural heritage. Innargi envisions to implement architectural attractive facilities leading to a much better visual and public acceptance.

- Noise pollution: Drilling and pumping activities can generate noise pollution, which can disrupt the tranquility of nearby communities, especially at night. This can be particularly problematic for those living close to proposed projects.

- Groundwater contamination: Deep geothermal systems involve pumping hot water from underground reservoirs. Incorrect design or constructed wells may have its integrity of the wells, there is a risk of groundwater contamination with potentially harmful chemicals from surface or deeper layers.

- Seismic activity: The injection of cold water into deep geothermal reservoirs can induce seismicity or noticeable earthquakes in some geological settings. The potential for such tremors can raise concerns among residents.

- Land subsidence: Although the mass balance will remain constant unlike with gas or oil production, the extraction of heat from reservoirs will lead to some shrinking of formation which is generally significant smaller than the gradual compaction of the overburden. Nevertheless, perception may be that cooling may cause subsidence of the land surface what can affect infrastructure, property values, and agricultural activities.



---

- Public knowledge and trust: Deep geothermal energy is relatively new in Denmark, and there is often a lack of public understanding and trust in the technology. This can make it challenging to gain widespread acceptance of proposed projects.

- Community engagement and participation: Lack of meaningful engagement with local communities can foster mistrust and resistance to deep geothermal projects. Open communication, transparent planning processes, and active involvement of affected residents are essential to build social acceptance.

- Economic viability and cost-sharing: The upfront costs of deep geothermal projects can be substantial, and there is a perception that the economic benefits may not be equitably shared among communities that host these projects. Addressing these concerns is crucial for long-term social acceptance.

- Comparative risks and alternatives: Deep geothermal energy must be compared to other renewable energy options and potential carbon dioxide capture and storage technologies in terms of environmental impact, safety, and cost-effectiveness.

- Continual monitoring and risk management: Deep geothermal projects require rigorous monitoring and risk management strategies to ensure the safe operation of the systems and minimize potential environmental and social impacts.

#### **4.3.5 Permitting**

The permitting process for deep geothermal projects in Denmark is complex

and involves several authorities at both national and local levels. Nevertheless, there is no clear flow chart available detailing out how the process is structured step by step.

The following paragraphs describe elements of the process that are available to ensure that deep geothermal projects are developed in a safe and sustainable manner, while also minimizing any potential environmental impacts.

##### **4.3.5.1 Preliminary Considerations**

Before initiating the formal permitting process, potential developers need to conduct thorough geological investigations to assess the feasibility of the project and determine the potential resource size. This involves seismic surveys, well logging, and other geophysical techniques to map the subsurface and identify suitable geothermal reservoirs.

##### **4.3.5.2 Pre-application Stage**

Once the initial feasibility studies are completed, the developer can submit a pre-application to the Danish Energy Agency (DEA). This pre-application serves as an informal notification to the DEA and allows the agency to provide feedback on the project's technical and environmental aspects.

##### **4.3.5.3 Environmental Impact Assessment (EIA)**

The next step involves conducting a comprehensive Environmental Impact Assessment (EIA) to evaluate the potential environmental impacts of the proposed deep geothermal project. This assessment considers factors such as noise, air quality, groundwater, soil, and biodiversity. The EIA is prepared by a qualified environmental consultant and submitted to the Danish Environmental Protection Agency (DEPA).

#### 4.3.5.4 Public Consultation

The DEA and DEPA organize public consultation periods to allow stakeholders, including local communities, environmental organizations, and the general public, to review the EIA and provide feedback. The developer must address any concerns raised during the consultation process.

#### 4.3.5.5 Planning Permission

If the EIA and public consultation are successful, the developer can apply for planning permission from the relevant local authorities. This involves submitting detailed plans for the project, including site layout, well design, surface facilities, and emergency response procedures.

#### 4.3.5.6 Water Act Permit

Deep geothermal projects require a permit under the Danish Water Act to abstract groundwater and discharge treated water back into the environment. The Ministry of Environment and Food (MoEF) assesses the project's water requirements, the quality of the abstracted water, and the impact on groundwater resources.

#### 4.3.5.7 Geosciences Act Permit

The Geological Survey of Denmark and Greenland (GEUS) issues a permit under the Danish Geosciences Act to carry out deep drilling activities. This permit ensures that the drilling operations are conducted safely and in accordance with geological regulations.

#### 4.3.5.8 Operational Monitoring

Once the project is approved and construction begins, the operator is required to continuously monitor the project's performance and environmental impacts. This includes monitoring groundwater levels, water quality, and emissions.

#### 4.3.5.9 Closure Plan

Prior to commencement of drilling, the operator must submit a closure plan outlining the procedures for decommissioning the project at the end of its lifespan. This plan includes plans for plugging the wells, restoring the site, and managing any residual impacts.

#### 4.3.5.10 Ongoing Oversight

The DEA and DEPA continue to monitor the project throughout its operation and post-closure phase to ensure compliance with environmental regulations and to address any potential issues.

The permitting process for deep geothermal projects in Denmark is designed to strike a balance between promoting sustainable energy development and minimizing environmental impacts. The comprehensive assessment and monitoring requirements ensure that deep geothermal projects are implemented responsibly and with due regard for the surrounding environment.

#### 4.3.6 Legislation

The 2018 Energy Agreement provides the main legislative framework for renewables and energy efficiency measures to achieve Denmark's national targets of at least 50% of energy demand by renewable energy in 2030. The agreement strongly promotes the modernization of the heating sector and indicates geothermal as an important resource for meeting a large share of Denmark's heating consumption needs in the future. Emphasis is also put on the development of electrical heating through heat pumps that will benefit from a reduced taxation.

In addition, the agreement extends until the end of 2024 the financial risk coverage for geothermal drilling first introduced in 2017 and commits to conduct an analysis of geothermal heat under the new frame.

As regards geothermal, a majority in the Danish Parliament in the Climate Agreement for Energy and Industry, etc. of 2020 agreed to look at the framework for geothermal heat. The following agreement under the Climate Agreement for Energy and Industry, etc. in 2021 decided to introduce separate rules in the Heat Supply Act for the price regulation of remote heat from geothermal plants, which would make it possible to establish large-scale geothermal plants for district heating in Denmark.

In March 2023, the Danish Parliament adopted a new law paving the way for Denmark's first large-scale geothermal installation in Aarhus. The Aarhus plant is expected to become the EU's largest of its kind (State of Green, 2023).

#### 4.3.7 Market trend

Denmark is among the European leaders in developing renewable energy sources, though despite the wide availability of heating and cooling infrastructure, it has so far not fully tapped into its geothermal energy potential. The geothermal sector in Denmark is driven by shallow geothermal developments, which according to Eurostat data represent 85 ktoe of renewable energy produced in 2017.

Denmark is strong with many large industrial actors involved in the district heating and cooling sector and the oil & gas sector, which guarantees the availability of know-how for further deployment of deep geothermal projects. Local utilities, such as the operators of the existing deep geothermal projects, can play a crucial role in the long-term planning required to scale up geothermal energy in Denmark.

The first geothermal project was developed by DONG (Danish Oil and Natural Gas Company), a public company established in

1974, as a 100 per cent state owned energy company. Between 1978 and 1982, DONG led a geothermal drilling campaign, and then developed the plant in Thisted from 1984. They developed a second plant in 2005 in Margrethe-holm. In 2006, after a merger of 6 power companies, the company became DONG Energy A/S (now it is Orsted) and decided in 2010 to relinquish its geothermal licenses in Denmark and in Europe.

In 2013, the project in Sønderborg was put into operation, in collaboration with DONG Energy, by Sønderborg Varme A/S which is a company owned by its 15.000 consumers (shareholders).

Innargi was founded in 2017 by A.P. Moller Holding in order to examine whether competences from many years in oil and gas could help unlock the potential of geothermal energy for district heating. Today, Innargi is jointly owned by ATP (Denmark's largest pension fund), NRGi (customer-owned utility company) and A.P. Moller Holding.

Since 2021, E.ON has taken over a majority stake of GEOOP, a Danish geothermal development company.

##### 4.3.7.1 District heating

Most of the Danish territory is suitable for geothermal district heating. Another aspect presented is that the existing infrastructure is well developed. Huge geothermal resources are documented in the subsurface below most Danish cities.

Looking at the current energy mix of the DH systems in Denmark, the challenge is to be less dependent on bio-energy and decarbonise the fossil fuel systems (based on coal, oil, peat and fossil gas) as illustrated in the graph below:

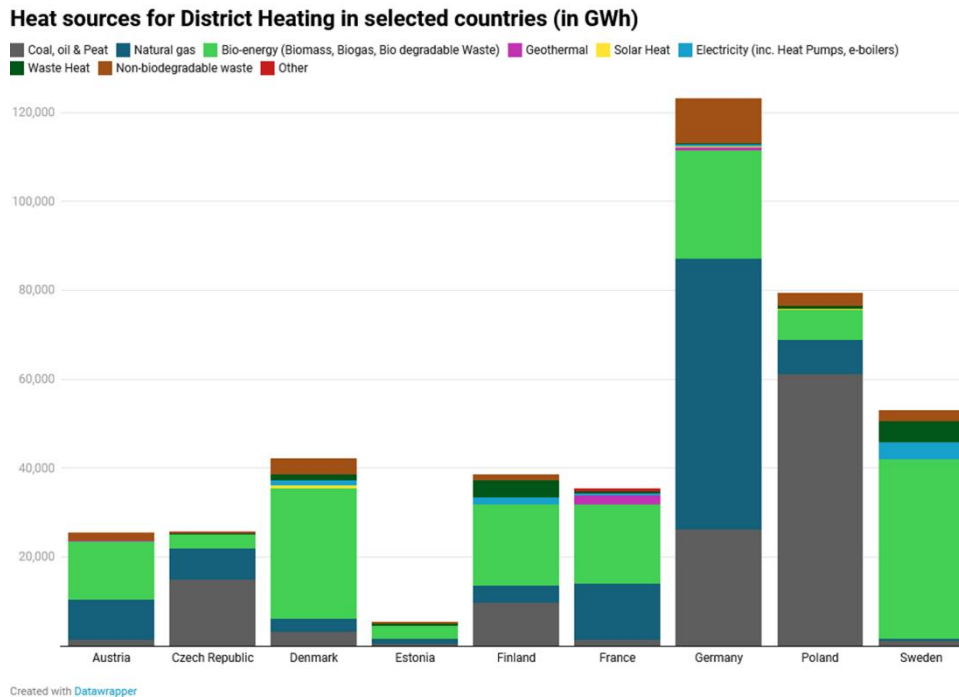

Figure 26: Heat sources for DH in selected countries (in GWh) (EuroHeat & Power, 2023)

With the total population of 5.6 million inhabitants the proportion of Danish population that can be served by geothermal district heating (with temperatures between 60 °C to 100°C at 2000m deep) is around 75%. This area includes regions that can be fully supplied with geothermal installations such as Københavns omegn, Nordsjælland, Østsjælland, Østjylland and Vest- og Sydsjælland (GEODH, 2014).

#### 4.3.7.2 Direct Heat Utilization is Expected to Drive the Market

Denmark has moderate temperature gradients, but widespread geothermal aquifers and district heating networks in most of the Danish towns supplying heat to approximately 60% of Danish households.

Table 6):

#### 1. Thisted Geothermal Power Plant

The Thisted Geothermal Power Plant is located in Thisted, North Jutland, and is the oldest geothermal power plant in Denmark.

Denmark's district heating production has reached 55 TJ in 2018.

Geothermal energy is a renewable energy source with vast potential. It carries the benefits of low CO2 emissions, low running costs, local production and high security of supply. And after investments, it has a long life. The geothermal reserves in the Copenhagen area in Denmark could cover 30-50% of the areas district heating needs for the next several thousand years (businesswire, 2020).

#### 4.3.8 Technology

##### 4.3.8.1 Current status

Currently three bigger plants are in operation (as also displayed in

It began operating in 1987 and has a capacity of 1.5 MW. The plant uses a doublet-type system to extract heat from a geothermal reservoir located about 4,000 meters (13,123 feet) underground. The extracted heat is used to generate electricity and provide district heating to nearby homes and businesses.

Table 5: Key facts – Thisted Geothermal power plant (GEODH, 2014)

## GENERAL

OWNER	ThistedVarmeforsyning (the local consumer owned district heating company)	OPERATOR	ThistedVarmeforsyning
REGION	Thisted		

## PROJECT

INHABITANTS CONNECTED	5016 (13000 inhabitants in town)	DESIGN OF THE DH	Water based with pre-insulated pipes
OTHERS USES (DRINKING WATER, CASCADE USES...)	No	PRODUCTION OF HEATING AND/OR COOLING	For district heating
PLANNING OF THE OPERATION (FROM PRE-STUDIES TO FULL COMPLETION)	1980 - 2001	DATES OF BEGINNING AND END OF CONSTRUCTION	1982 - 1984
ADMINISTRATIVE PERMITS	None	DIFFICULTIES FACED	Production from cooler reservoir due to declining transmissivity in first tested deeper reservoir. Tax on power for electric heat pump causing shift to absorption heat pumps.

## FINANCING

INVESTMENT FOR GEOTHERMAL WELL	6 million euros for two wells	INVESTMENT FOR GEOTHERMAL HEATING STATION	6 million euros
INVESTMENT FOR DH NETWORK AND SUBSTATION	Not part of geothermal plant	FINANCING (BANKS, FUNDS, PPP...)	Owner, former co-owner and EU grants
AMOUNT OF SUBSIDIES IF ANY	2,3 million euros in EU grants		
COST OF THE MWH SOLD	Not applicable. Consumers pay all costs for heat from the net. This includes network costs and costs for heat production from different heat production units.		

## TECHNICAL

INSTALLED CAPACITY (MWTW)	78	SUBSURFACE AND SURFACE TECHNICAL SCHEMES	One production and one injection well. Absorption heat pumps driven by straw boiler.
OPERATING TEMPERATURE OF THE DH	Winter/summer: Supply: 76/70 °C; Return: 40/44 °C	TEMPERATURE OF THE GEOTHERMAL RESOURCE (PRODUCTION - INJECTION)	43 °C / 11 °C
GEOTHERMAL FLOW RATE	Up to 200 m <sup>3</sup> /h	HEAT PUMP IF ANY (POWER IN MWE AND COP)	Absorption heat pumps: 7,7 MWth / COPth 1,7
INNOVATION IF ANY	The use of absorption heat pumps driven by straw district heating boiler, which makes it free to drive the heat pumps.	DH LENGTH	219 km



## 2. Sønderborg Geothermal Power Plant

The Sønderborg Geothermal Power Plant is located in Sønderborg, Southern Denmark, and began operating in 2001. It has a capacity of 2 MW and uses a similar doublet-type system to extract heat from a geothermal reservoir located about 3,000 meters (9,843 feet) underground.

The extracted heat is used to generate electricity and provide district heating to nearby homes and businesses.

## 3. Copenhagen (Margaretenholm) Power Plant

The Margretheholm plant exploits a geothermal reservoir in the Lower Triassic Bunter Sandstone Formation at 2.6 km depth where 19% saline geothermal water is available at c. 74°C. The plant is designed to extract 14 MW heat from 235 m<sup>3</sup>/h geothermal water and transfer 27 MW heat to the district heating net by heat exchange and through 3 absorption heat pumps driven by 14 MW steam primarily from wood pellet-based CHP plant.

Table 6: Geothermal (ground-source) heat pumps as of 31 December 2019 (Mathiesen, 2021)

Locality	Ground or Water Temp. (°C) <sup>1)</sup>	Typical Heat Pump Rating or Capacity (kW)	Number of Units	Type <sup>2)</sup>	COP <sup>3)</sup>	Heating Equivalent Full Load Hr/Year <sup>4)</sup>	Thermal Energy Used <sup>5)</sup> (TJ/yr)	Cooling Energy <sup>5)</sup> (TJ/yr)
Thisted	42	7000	1	V			84,4	
Copenhagen	72	14000	1	V			44	
Sønderborg	48	8500	1	V			23,8	
Shallow, for DH		7460	4	H, V			71	2
Distributed in DK		714 MW all together	65000	V, H			3800	
<b>TOTAL</b>		751000	65007				4023,2	2

This table should report thermal energy used (i.e. energy removed from the ground or water) and report separately heat rejected to the ground or water in the rejected to the ground in the cooling mode as this reduces the effect of global warming.

<sup>1)</sup> Report the average ground temperature for ground-coupled units or average well water or lake water temperature for water-source heat pumps

<sup>2)</sup> Report type of installation as follows: (TJ = 10<sup>12</sup> J)  
 V = vertical ground coupled  
 H = horizontal ground coupled  
 W = water source (well or lake water)  
 O = others (please describe)

<sup>3)</sup> Report the COP = (output thermal energy/input energy of compressor) for your climate - typically 3 to 4

<sup>4)</sup> Report the equivalent full load operating hours per year, or = capacity factor x 8760

<sup>5)</sup> Thermal energy (TJ/yr) = flow rate in loop (kg/s) x [(inlet temp. (°C) - outlet temp. (°C))] x 0.1319  
 or = rated output energy (kJ/hr) x [(COP - 1)/COP] x equivalent full load hours/yr  
 Cooling energy = rated output energy (kJ/hr) x [(EER - 1)/EER] x equivalent full load hours/yr

### 4.3.8.2 Innargi & the Aarhus case

In Denmark, the innovation is the application of the project portfolio approach connected. The largest geothermal DH is currently developed in Aarhus with 19 wells planned utilized by Innargi. Innargi is set out

and up to execute that approach with the goal of “decarbonizing heat – one community at a time” (unlocking the potential of geothermal energy on an industrial scale).

---

## 1) Company structure

### A) Ownership Structure

Innargi is a joint venture company owned by three major stakeholders (FIH Partners, 2022):

- ATP: Denmark's largest pension fund,
- *NRGi: A customer-owned utility company in Denmark,*
- *A.P. Moller Holding: A Danish investment and holding company.*

These three owners have significant expertise and experience in renewable energy, finance, regulation, operations, building and construction, project development, and human resources. Their collective ownership ensures a strong foundation for Innargi's growth and success.

### B) Operating Structure

Innargi operates as a vertically integrated company, encompassing all aspects of geothermal energy development and utilization. This includes:

- *Reservoir Management: Identifying, assessing, and developing geothermal reservoirs,*
- *Engineering and Drilling: Designing, constructing, and drilling geothermal wells,*
- *Power Plant Operations: Operating and maintaining geothermal power plants,*
- *Heat Distribution: Distributing geothermal heat to communities,*
- *Project Development: Bringing geothermal projects from concept to completion.*

This vertical integration allows Innargi to control the entire value chain of geothermal energy, from resource identification to heat delivery. This in turn enables the company to optimize efficiency and reduce costs, contributing to the overall affordability of geothermal energy.

### C) Senior Management Structure

Innargi's senior management team comprises experienced professionals with extensive expertise in geothermal energy, finance, regulation, operations, building and construction, project development, and human resources. Their leadership is crucial for guiding the company's strategic direction and ensuring its continued growth and success.

In summary, Innargi's company structure is characterized by (INNARGI, kein Datum):

- *Shared ownership by three major stakeholders: ATP, NRGi, and A.P. Moller Holding,*
- *Vertical integration: Control over all aspects of geothermal energy development and utilization,*
- *Experienced senior management team: Leaders with expertise in oil, gas and geothermal energy.*

## 2) Business model

- *Finance, develop, construct, and operate large-scale geothermal heating plants for district heating companies.*
- *Strong focus on PR and visibility – source: (INNARGI , 2024).*



### We take the initial risk

We take 100% of the risk and cost of the initial exploration phase. We have the funding to take the risk, see things through, and invest in long-term partnerships, and we require no payment until the heat flows.



### Competitive pricing

Before Innargi, all geothermal projects were one-offs. By industrializing geothermal heating, we are both driving down costs and leveraging the learning effect.



### 30 years of dependable heat

We operate the facility for 30 years and guarantee heat availability and performance when it is up-and-running. Because geothermal is baseload, it is always there when you need it.



### We engage locally

Understanding local plans and regulations and securing local permissions is our responsibility. We invest in securing the support of local communities – both those who govern them and those who live in them.

Figure 27: Innargi website – What we do (INNARGI, kein Datum)

### 3) Financing

Innargi has raised over €500 million in funding for its geothermal projects from a variety of sources, including:

- *Private equity*
- *Debt financing*
- *Government grants & support from the European Union's Horizon 2020 research and innovation program.*
- *Danish Energy Agency*
- *Vestforbrænding, Denmark's largest waste management and energy company*
- *Investment funds.*

### 4) Aarhus – geothermal project

Innargi's Aarhus project is one of the currently best promoted projects over Europe. The scope of the project and the project itself is well described in various sources such as:

- [Project Aarhus, Denmark - Innargi](#) (INNARGI, 2024)

- <https://innargi.com/green-milestone-for-denmark-geothermal-drilling-has-started-in-aarhus/> (INNARGI, 2023)
- [Denmark Gives Green Light to Drill for Geothermal Heat - Bloomberg](#) (Bloomberg, 2023)
- [Denmark to host EU's largest geothermal heating plant in Aarhus - Industry Europe](#) (Industry Europe, 2022).

#### Key facts:

- Consist of 17 wells, constructed on seven sites,
- Geothermal heating plant with a total capacity of 110 MW (will become the largest in the EU),
- First heat will be delivered in 2025 and all seven sub-plants will be completed in 2030,
- Provided 20% of the city's district heating by 2030,
- Project aims to achieve goal of net zero CO<sub>2</sub> emissions by 2030, by cutting some 165,000 tons of them annually.

---

### 4.3.9 Key lessons learnt from Denmark to replicate in the Netherlands

Following table outlines the key learnings we consider to be valuable for the acceleration process with the Netherlands:

**Table 7: Key learnings – Denmark**

<b>High DH coverage of buildings for heating &amp; cooling</b>
<b>Communities' engagement in DH</b>
<b>Large scale (&gt;15 wells per city) geothermal drilling sequence</b>
<b>Modification of heat net legislation</b>
<b>Long-term (30 year) heat contracts</b>
<b>Pension funds participating in geothermal company</b>
<b>State of Green (State of Green, 2024)</b>
<ul style="list-style-type: none"><li>- acts as a one-stop-shop to more than 600 Danish businesses, agencies, academic institutions, experts and researchers. State of Green connects leading Danish players working on the global transition to a sustainable resource-efficient society.</li><li>- State of Green's work is built on international partnerships, solutions, and insights within energy, water, cities, and circular economy.</li><li>- Through decades of experience, Denmark has turned challenges within four areas into opportunities – energy transition, water management, green cities, circular economy</li></ul>
<b>Exploration risk taken by private company</b>



# France





## 4.4 France

### 4.4.1 General

The geothermal electricity market is partly hampered, since 2020, by discussions concerning induced seismicity in the Upper Rhine Graben area. The feed-in tariff for new geothermal, power projects in France was suspended. France was a hotbed of activity concerning Enhanced Geothermal Systems (EGS) but projects never materialised.

Geothermal lithium and combined heat & power (triple-generation) are now the main drivers in this market. There are two main electricity projects in operation - Soultz and Bouillante 1&2 (Guadeloupe). Five permits have been granted for exploratory drilling whilst 15 are under instruction. France generated 127,06 TWh in 2022 with a capacity of 17.2 MWe. The load factor was 84%.

Following the trend from 2021, France continued to be the leading country in terms of geothermal DH projects commissioned,

with a total of 5 - adding an additional of 48.7 MWth to existing capacity. These systems provided renewable heating to the residential sector in the Île-de-France region and Bordeaux in the Nouvelle Aquitaine region. France remains the largest geothermal district heating country in the European Union and second to Iceland across Europe.

#### In operation:

- 2500 MWth of heating and cooling in 2020.
- Almost 600 MWth of deep geothermal energy reservoir in the Paris region.
- 72 deep geothermal energy installations in Ile-de-France with 2 TWh of energy production. Most of them are geothermal heating networks.
- Geothermal energy is also produced in the New Aquitaine region.

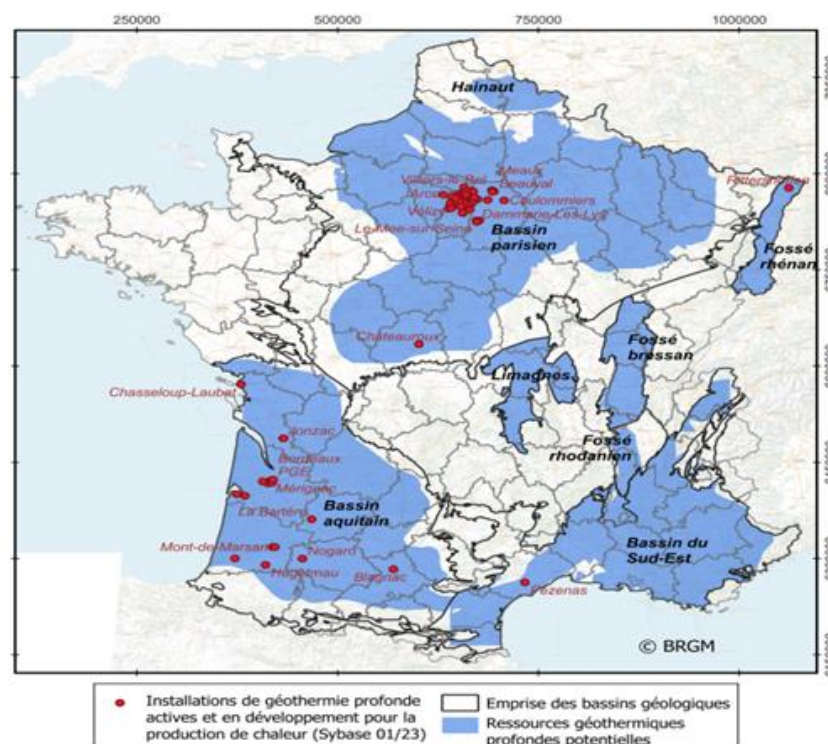

Figure 28: Overview of geothermal installations & potential resources in France (BRGM, 2024)

---

French government published a geothermal national plan on 2 February 2023 and updated on 22 December 2023. The aim is to make France a leader in geothermal energy in Europe, both in terms of renewable energy production and industrial development:

- *Geothermal heating networks: +40% of deep geothermal projects launched by 2030.*
- *Geothermal heat pumps: Double the sales of heat pumps from 4.6 TWh in 2023 and 7 TWh of final consumption renewable heat by heat pumps in 2028.*

The objective is to save 100 TWh of Russian gas imports, which is more than the Russian imports before the invasion of Ukraine. For reference:

- *75% of the energy consumed in France comes from fossil fuels or gas.*
- *1% comes from geothermal energy.*

#### 4.4.2 Financial instruments

The French geothermal district heating industry is well established and experienced as many of the 74 existing installations have been installed in the 80s. Developments were anew for the past 15 years, benefiting from the new ADEME Heat Fund.

The Agence de la transition écologique (ADEME) manages the 'fonds chaleur' (heat fund) which will be increased to 820 millions in 2024, instead of 600 in 2023.

SAF Environnement Fund is a guarantee fund for geothermal district heating covers geological risk and protects operators against the risk faced during the exploration and exploitation phases of geothermal projects.

France has put several instruments in place to forward geothermal energy utilisation for electricity as well as for heating and R&D.

#### 1) Electricity

Geothermal mostly benefits from the new feed-in premiums regime introduced in 2016, consisting of a premium paid to the producers of RES electricity to top up the revenues they receive from the sale of their electricity directly on the market.

However, this operational support to geothermal electricity production (246€/MW) is not secured for the coming years.

#### 2) Heating and cooling

Geothermal heating and cooling is mostly financed by the Heat Fund through regional aids or specific call for projects, while the SAF environment fund insures investors against the geological risks related to high-investments projects.

Additional measures to support heating and cooling (notably for shallow systems) include Energy transition tax credit, 0% interest loans, Energy saving certificate scheme, 5,5% VAT for renewable district heating.

#### 3) Innovation

Regarding Innovation and R&D, the Investments for the Future programme is the main financial instrument for the geothermal sector, increasing the potential of exploitable geothermal resources for heat and electricity.

---

#### 4.4.2.2 Historical outline – Development of the French heat fund

The budget of the heat fund has been increased by €150 million in 2022 to reach €520 million. Geothermal heating projects are eligible for this financial support fund for the development of renewable heat production.

A de-risking mechanism managed by ADEME to cover geological risks based on two complementary mechanisms (Association Française des Professionnels de la Géothermie, 2021).

- A guarantee that covers short-term risks in case of temperature and/or flow rate that does not comply with the expected value.
- A guarantee that covers long-term risks in case of partial or total damage that hinders the exploitation of geothermal resources.

Amendment to the first paragraph of Article L. 122-1 of the French Construction and Housing Code: "In order to promote the use of renewable energies, buildings shall be subject to a technical and economic feasibility study prior to their construction or energy renovation, which shall evaluate the various energy supply solutions, except in cases where the competent authority for energy distribution services imposes the use of a specific energy supply." completed by the sentence: "This feasibility study shall include surface geothermal energy."

The late 1970s saw the birth in France of a heat producing industry built on the use of vast geothermal resources located 2,000 metres under the Greater Paris Region. This home-grown source of energy at a time when the price of fossil fuels was exploding, in the wake of the first oil crisis of 1973, offered temperatures of 60 to 85°C, therefore directly usable for heating residential complexes with or without shared heating networks.

This industry was initiated back in 1969 by French engineers with a world premiere, the geothermal dual drilling at Melun l'Almont in the Seine et Marne department near Paris. This approach went on to expand to several

French regions, especially the Aquitaine Region centred on Bordeaux.



To support this expansion, in 1974 the authorities set up a technical committee – the Geothermal Committee – placed under the authority of the Ministry of Industry. In 1982, the Geothermal Committee was transferred to AFME (French Agency for Energy Management) – a newly created public agency later to become ADEME (French Agency for the Environment and Energy Management) in 1991.

In France, underground property rights belong to the State, which may or may not permit their use. The Mining Code was also enacted to ensure a legal framework for operations, with a Decree published in 1978 permitting the search for, and the use of, deep level geothermal resources.

In 1979, when the second oil crisis hit, GÉOCHALEUR (the National Company for Applying Geothermal Energy) was founded. This body was tasked with encouraging the expanding use of geothermal energy to save imported energy and further social aims.

Lastly, in the early 1980s, a mechanism for covering geological hazards was set up, initiated by the Ministry of Industry with, in 1981, the creation of the Long-Term Guarantee Fund to cover the operating life of geothermal works. This duration was initially planned to last for 15 years (before later being extended to 25 years). In 1982, the Short-Term Guarantee Fund was set up to cover geological risks linked to the search for geothermal resources, namely the risk that no usable resource would be found.



These two funds were managed by a Caisse des Dépôts et Consignations (CdC) subsidiary, the Auxiliary Financing Company for Geothermal operations (SAF-Géothermie), created in 1980 for this purpose before it became SAF-Environnement in 1993. At that time, it was the first guarantee mechanism of this kind ever created.



In parallel, a financial support mechanism for operations, taking the shape of subsidies and repayable advances was also set up. It was this policy taken together that allowed the deployment, between 1981 and 1986, of low temperature geothermal energy in France, with unrivalled success not seen in the rest of the world.

Today, some two-thirds of the operations kicked off in the early 1980s are still in operation, cumulating over 500 MW of heating power installed and the equivalent of over 200,000 homes connected. Over a 35-year period, this represents fossil fuel savings of some 4.5 million tons and some 9 million tons of CO2 emissions avoided.

After a long twenty-year period from 1987 to 2007, when no new operations were conducted in the Paris Basin and only three in the Aquitaine Basin, at the end of the 1980s, a relaunch in activity was initiated after 2008. To do this, a new public policy of financial support for drilling new wells was put into place thanks to the renewable heat fund created by ADEME in 2009.

In parallel, as the Short-Term Fund was eliminated in 1996, a new mechanism for covering geological risk, coupling a Short-Term and a Long-Term aspect, was created

ahead of time in 2006, to support this relaunch of activity. Existing 1980s operations remained covered by the Long-Term Fund until its closure in 2013 (the year when the guarantee for the last operation taken on 25 years earlier expired).

Since then, some ten new operations have come on stream and most of the existing installations dating back to the 1980 and in place in the Paris Region have, or will in the coming years, seen new drillings to replace the original ones that have reached the end of their lives. This way, the life of these existing installations will be prolonged for another thirty years.

Although the new operations undertaken, for now, remain dedicated to using the Dogger geothermal reservoir in the Paris Basin, a stated aim for the coming years is to develop installations in the Paris Region that use aquifers other than Dogger, like Triassic for example, or in other geographical areas (Alsace, Rhone River Corridor, Mediterranean areas, etc.) and to relaunch work on the Aquitaine Basin.



To conclude, if low temperature geothermal energy is what it is in France today, with – despite the teething troubles encountered – a large number of operations kicked off some 35 years ago and still in operation today, this is thanks to public support and to the technical expertise developed progressively by the operators. It has also become what it is, thanks largely to the determining part played by the guarantee mechanisms put into place.

The Short-Term mechanism, by lifting the geological risk factor inherent in geothermal operations, allowed the initial drilling and the Long-Term mechanism, by covering the repair work due to using geothermal fluids, ensured that installations were kept in sustainable use over the long term.

Regarding the guarantee mechanism created in the early 1980s, the history and results of which are the focus of this report, and we also need to stress the usefulness of such a mechanism in relation to the public purse.

Hence, for the Short-Term Fund, investments worth €198 million were guaranteed for the drilling phase, with €4.7 million paid by the public purse to the Funds, which means that for every €1 paid by the State, €42 of investments were guaranteed. For the Long-Term Fund, investments worth €259 million were guaranteed, taking into account not only the cost of dual wells but also that of the related production equipment (pumps, heat exchangers, etc.) and this for tens of operations nationwide. The payments made by the State for this Fund came to €8.5 million, which means that for every €1 paid by the State, €33 of investments were covered for 25 years.

Lastly, with this guarantee tool that was both a forerunner and a rather innovative one,

France gained real life experience that can easily be transposed outside of France, as was the case with the Netherlands a few years ago. Although the production of geothermal heat is come second in renewable energy contributions to heat production worldwide, widely distributing this experience would no doubt allow further increasing its contribution.

#### 4.4.2.3 French Risk Mitigation scheme

The key for success in Paris basin has been the risk mitigation system put in place by ADEME in 1980 and revamped already in 2008.

A financing system to cover the geological risk based on two complementary mechanism:

- *Short-term risk: based on the socialization of risks and guarantees for geothermal wells,*
- *Long-term risk: beginning at the starting up of the geothermal plant and guarantees covering the sustainability of the geothermal resources and the potential risk of resources depletion during a 15 years period.*

#### Operating the French RMS:

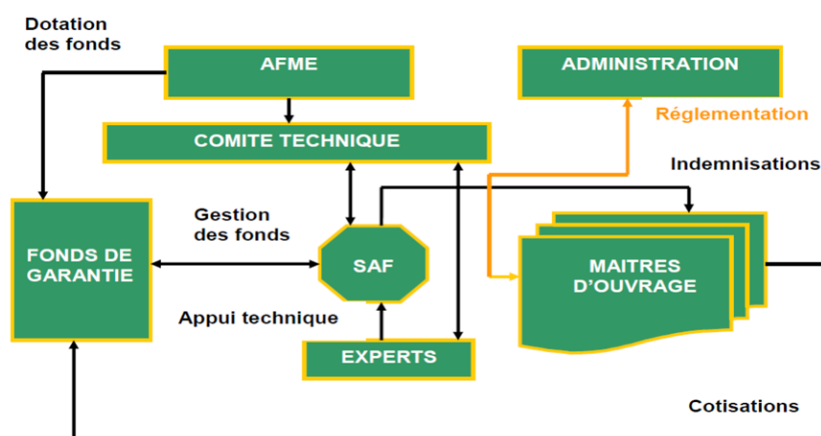

Figure 29: French Risk Mitigation Scheme



**Conditions to subscribe to the insurance:**

- Acceptance of the project by a technical committee after a detailed expertise including, technical, economic, financial and juridical aspects.
- Payment of 3 to 5% of the covered cost depending on the zone (for a Dogger doublet of 10 M€ the insurance cost is around 350K€).

**Result of the last fund Short- and Long-Term aggregated Period 2008 – 2020:**

*Resources 24 M€*

- Public Participation (ADEME) at 47%.
- Private participation (developers) at 53%.

*Expenses 24 M€*

- Reimbursement for failures 14 M€ - 53%.
- Management and expertise 4 M€ - 15%.

- Reserve after 12 years of operations 8M€ - 32%.

**Short-Term benefits**

- 80 geothermal wells covered (33 doublet and triplet + 13 single wells).
- 11 reimbursement including: 7 failures partial or total and 4 related to extra costs.

**Long-Term achievements**

- 34 contracts signed for 400 years of coverage.
- Failure reimbursed for an average of 3%/year.

**4.4.2.4 New French risk mitigation scheme (RMS)**

A new RMS in order to attain the PPE 2030 (Energy Programme defined by the Ministry of environment elaborated in cooperation with the French geothermal Association):

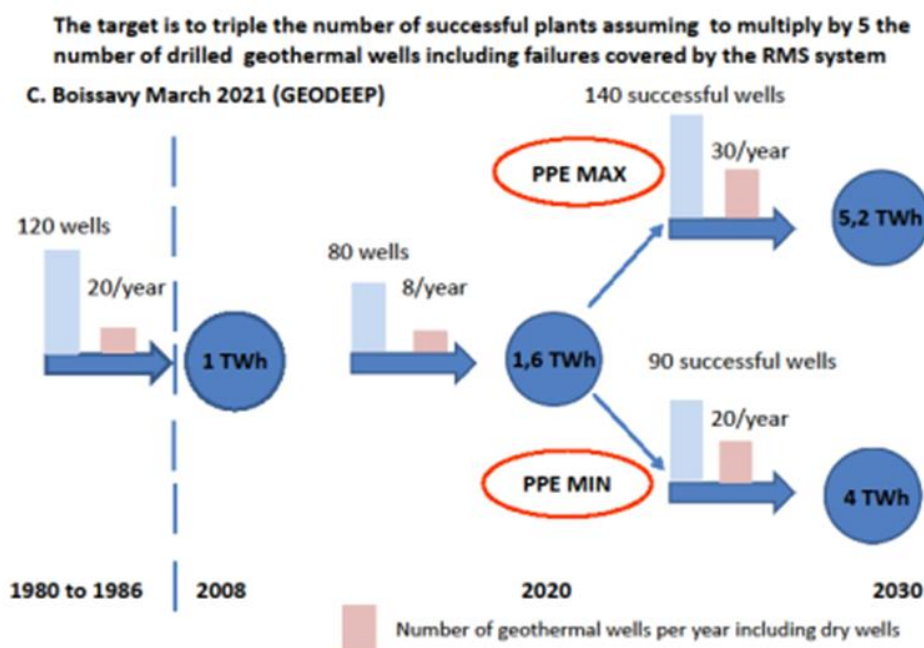

Figure 30: Future geothermal development in France

- 3 zones of risk defined in the country / RMS:

Figure 31: Risk zones (new RMS in France)

	Zone 1 Well known Low risk	Zone 2 Some knowledge Medium risk	Zone 3 Unknown High risk
% of failure for the first drilling before detailed studies	First well - 6% Drilling campaign - 11%	First well - 33% Drilling campaign - 57%	First well - 60% Drilling campaign - 85%
% of failure for the first drilling after detailed studies and geophysics	First well - 5% Drilling campaign - 9%	First well - 25% Drilling campaign - 45%	First well - 40% Drilling campaign - 67%
Example of different zone regarding the geology and hydrogeology	Eastern part of Ile de France (IDF) region in the Dogger reservoir	Western part of IDF, Aquitaine, Hauts de France, Occitanie when oil & gas drillings	All the other part of the French territory without oil & gas drillings
Criteria for the geology to attain the geothermal reservoir	Good geological knowledge between the surface and the top of the reservoir	Average geological knowledge with some deep drilling to calibrate	Poor geological knowledge without deep wells and sometimes no geophysics
Criteria regarding the potential geothermal reservoir productivity	Good quantitative value of the geothermal reservoir with existing pumping tests	The geothermal resource is poorly exploited without REX and stratigraphic correlations	The geothermal resource is not exploited and unknown without any testing

- Utilization of probabilistic plots depending of the level of risk in each zone:

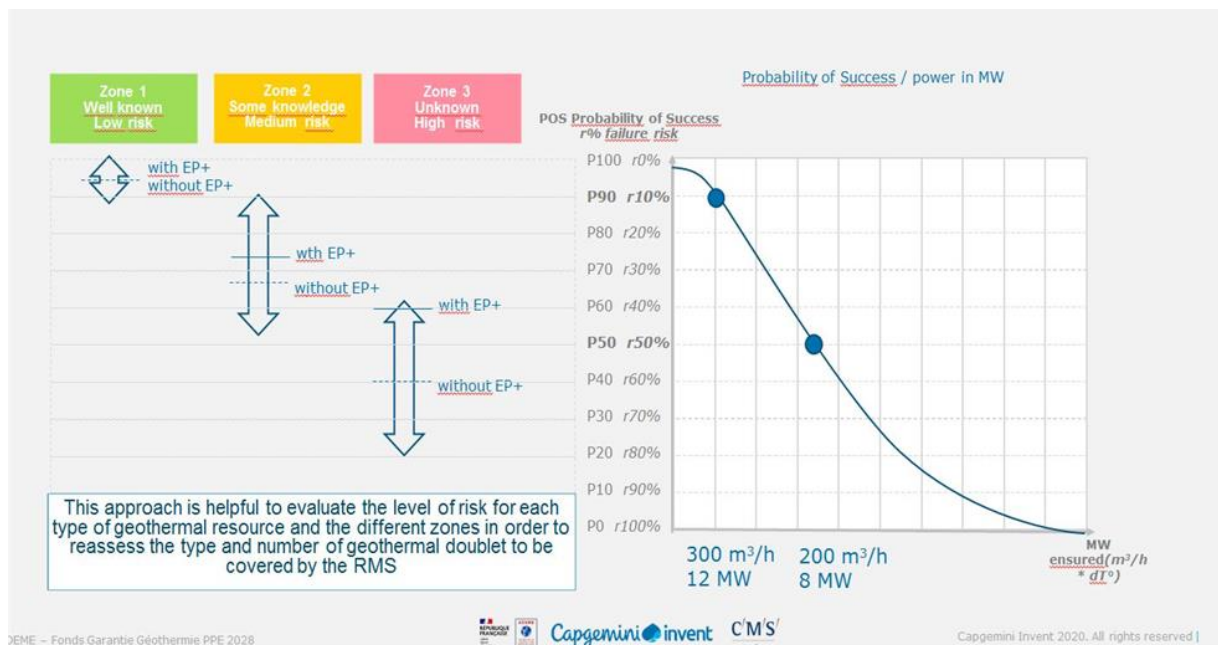

Figure 32: Probabilistic plots depending of the level of risk in each zone (new RMS in France)

- **Summary:**

- Same system with the Short and the Long-term warranty,
- Reimbursement in case of failure at 90% on the entire territory,
- Preliminary studies including seismic are included in the CAPEX to be reimbursed in case of failure,
- France divided in 3 zones from well-known zones like Ile de France, known zones with some deep wells and unknown zones where preliminary investigations are mandatory,
- Premium are adapted to the 3 zones from 5% in Zone 1, 10% in zone 2 and 15% in zone 3,
- For the Long-Term fee at 20 to 25 K€/year,
- Management and expertise would be amended but will remain close to the existing one,
- Administration of the RMS will remain by Caisse des Dépôts et Consignations.

- **RMS planning to be operational:**

- The study to establish the new Fund has been finished in April 2020,
- Due to the fact that there is a strong state participation, the project has to be submitted to the approval of the DG COMP in Brussels,
- EC approval of notification in July 2023: 195,6 millions €,
- Agence de l'environnement et de la maîtrise de l'énergie («ADEME») for maximum 140

millions euros, to build guarantee fund,

- contributions (fees) from projects developes could be 55,6 millions d'euros,
- Launch of the fund anticipated beginning of 2024.

#### 4.4.3 Governance

For deep geothermal, the French market is notably carried by the large French energy groups and their subsidiaries, but several smaller companies and SMEs are also key in geothermal development. In addition, the role of specific financial institutions, most notably the “Caisse des Dépôts et Consignations”, should be underlined as it has been instrumental in allowing some recent developments in innovative technologies.

##### 4.4.3.1 Key bodies

- Ministry for Ecology, setting the legislative framework;
- French Energy Agency (ADEME), financing renewable energy projects, notably on heating and cooling;
- National Agency for Research, funding RD&I projects;
- Prefectures, setting the day to day regulatory framework of project development;
- Commission for Energy Regulation (for electricity and gas);
- Caisse des Dépôts et Consignations, France's Public Development Bank
- National Investment Bank (BPI), focusing on SMEs investments;
- National Geothermal Association. French geothermal association of professionals (AFPG), Syndicate of renewable energy (SER).

#### 4.4.4 Social acceptance

Two main issues that damaged the image of geothermal in France can be reported:

- **Seismicity in Vendenheim in 2020-2021:** The company Fonroche geothermie developed an EGS project in Vendenheim. A first seismic event of 2.8 was firstly felt in October 2020, then a second one of 3.4 has been reported in December 2020 as induced seismicity for this geothermal project. The company disputed the origin and the legal case is still ongoing. But the French States asked then INERIS/BRGM to publish a guide on seismicity for the geothermal stakeholders. The local authority of Alsace put a moratorium on geothermal for 2 years from 2021.

- **Issue in Lochwiller in 2008** with a shallow geothermal drilling for installing and geothermal heat pumps systems in a private house. The drilling failed and created an incident: anhydrite swelling damaged more than 100 historic houses in the town of Lochwiller. The drillers contracted to this project didn't have the French qualification to drill.

#### 4.4.5 Regulations

##### 4.4.5.1 Permitting

The French mining code states:

- Titre minier: exclusive right but it is not an authorize to start works,
- Titres de recherches/exploration (PER) or exploitation (concessions): delivered by national minister (instruction can be local or national),
- Travaux miniers: only the owner of a permit can ask for an authorization to work (DAOTM) inside the perimeter of the license,
- Authorization for mining works delivered by prefectural decree,
- Issue of the mining code is that it is not covering UTES,
- Drilling companies must have an approved geothermal drilling qualification to limit risks and to guarantee the quality of the drilling. This qualification recognises professional, technical and financial capacities to carry out geothermal drilling.

The permitting process for deep geothermal projects in France has been simplified and involves several steps at both the local and national levels. The following flow chart provides a simplified overview of the process:

**Table 8: Permitting process in France**

Steps	Deliverables
<b>Step 1: Pre-permitting Phase</b>	1. Site Identification and Feasibility Study: Identify a potential deep geothermal site and conduct a feasibility study to assess its viability for power generation or district heating.
	2. Environmental Impact Assessment (EIA): Prepare an EIA to evaluate the potential environmental impacts of the project, including the impact on groundwater resources, air quality, and biodiversity.
	3. Public Consultation: Engage with local stakeholders and the public to gather feedback on the project and address any concerns.
<b>Step 2: Administrative Permitting</b>	1. Authorization for Exploration Drill: Obtain an authorization for exploration drilling to collect data on the geological and geothermal characteristics of the site.

	<ol style="list-style-type: none"> <li>2. Production Permit: Apply for a production permit if the exploration drilling results indicate the potential for power generation or district heating.</li> <li>3. Prefecture Review: The prefecture, the administrative authority responsible for granting permits, reviews the submitted documents and organizes a public inquiry to gather feedback.</li> <li>4. Permits Issuance: If the project is deemed environmentally acceptable and meets all technical requirements, the prefecture grants the necessary permits.</li> </ol>
<b>Step 3: Construction and Operation</b>	<ol style="list-style-type: none"> <li>1. Construction Approval: Obtain construction approvals from the relevant local authorities.</li> <li>2. Construction Phase: Implement the deep geothermal project, including drilling wells, installing power generation or heat distribution systems, and connecting to the electricity grid or district heating network.</li> <li>3. Operation Phase: Operate the deep geothermal project in accordance with the granted permits and applicable environmental regulations.</li> </ol>
<b>Step 4: Monitoring and Reporting</b>	<ol style="list-style-type: none"> <li>1. Continuous Monitoring: Continuously monitor the project's environmental performance, including water quality, air emissions, and seismic activity.</li> <li>2. Regular Reporting: Submit regular reports to the authorities on the project's operation, environmental performance, and compliance with regulations.</li> </ol>
<b>Step 5: Permit Renewal and Decommissioning</b>	<ol style="list-style-type: none"> <li>1. Permit Renewal: Apply for permit renewals before their expiration to continue operating the deep geothermal project.</li> <li>2. Decommissioning Plan: Prepare a decommissioning plan outlining the steps for dismantling and restoring the project site to its original condition.</li> <li>3. Decommissioning Execution: Execute the decommissioning plan safely and effectively.</li> </ol>

#### 4.4.5.2 Environmental regulations

The main environmental regulations for deep geothermal projects in France are:

- **The French Mining Code:** This code regulates the exploration, exploitation, and preservation of mineral resources, including deep geothermal energy. It requires that all deep geothermal projects obtain a permit from the Ministry of Energy and Environment.
- **The Water Code:** This code regulates the use and protection of water

resources. It requires that all deep geothermal projects obtain a water permit from the relevant local authority.

- **The Environmental Code:** This code sets out general environmental protection requirements. It requires that all deep geothermal projects conduct an environmental impact assessment (EIA) and submit a management plan to mitigate potential environmental impacts.



In addition to these general regulations, there are also a number of specific regulations that apply to deep geothermal projects in France. For example, there are regulations that limit the amount of water that can be withdrawn from the ground, the temperature of the water that can be discharged, and the amount of noise that can be generated.

The French government is committed to the development of deep geothermal energy, but it is also committed to protecting the environment. The environmental regulations for deep geothermal projects in France are designed to ensure that these projects can be developed in a way that is both environmentally sustainable and economically viable.

#### 4.4.6 Legislation

The Energy transition for green growth Act, provides the main legal framework of France renewable energy policy, setting objective of 23% RES by 2020 and 32% by 2030. In 2030 renewable energy sources should account for 40% of total electricity generation and 38% of final heat consumption.

The Multiannual Energy Planning (Programmation Pluriannuelle de l'Énergie or PPE) adopted by the end of 2019, sets out specific targets for geothermal development:

- for electricity production, it indicates an increase from the 8 MW of installed capacity in 2018 to 24 MW in 2023
- for heating consumption (district heating+geothermal HP), a projection of 7,5TWh for 2023 is planned.

#### Key points of the 2023 National action plan:

1. Strengthening of the surface geothermal drilling capacity to meet demand from the residential and tertiary sectors.

*National support of professional training via an Engineering of Professional Training & Innovation Scheme.*

2. Simplifying regulations to encourage the development of surface geothermal projects.

*Regional maps will be produced to refine the geothermal national map and to specify better the nature of the geological phenomena.*

3. Promotion of installations of geothermal heat pumps in residential and tertiary sectors.

*For any installation of a geothermal heat pump to replace an old thermal boiler, households will be given a 5,000€ incentive regardless of income level as of March 2023 3-to-6-year contracts for local authorities, companies and associations to support them in a range of projects, whether associated with a heating network.*

4. Improving knowledge of the subsoil to promote the launch of deep geothermal energy.

*An extension of the geothermal guarantee fund for deep aquifers has been pre-notified in December 2021 to the European Commission for an amount of €45 millions of public aid.*

5. Raising awareness to increase the skills of local players and to boost by 40% deep geothermal projects launched by 2030.

*At least one geothermal specialist for each of the thirteen administrative regions in metropolitan France.*

*Use of geothermal cooling to limit the electricity consumption of air conditioning to avoid the aggravation of urban heat islands during heatwaves.*

*Development of geothermal energy in the agri-food and industrial sectors, and in particular greenhouses, which today rely mainly on natural gas.*

6. Stimulate new projects and encourage new financial arrangements in geothermal energy

*The budget for the heat fund to promote new projects has been increased by 150 million in 2022 to reach €520 million.*

In France, regulating deep geothermal energy is a state competence: the central and so-called 'deconcentrated' bodies hold most of the competences, specifying the conditions in which a geothermal project can be deployed from the exploration phase to the long-term exploitation.

The territorial authorities<sup>4</sup> (communes, regions) play a key role showing (or not) the will to welcome deep geothermal energy on their territories and often participating in its funding.

They are also the main contact with the local population, regarding the overall "acceptability" of geothermal projects. The 'Energy transition for green growth Act' provides the main legal framework of the French renewable energy policy, and the Multiannual Energy Planning programme sets out specific targets for geothermal development. Current targets specify for

electricity production a growth 8 MW (2018) to 24 MW (2023) of installed capacity; for heating consumption based on deep geothermal, a projection of 2,9 TWh for 2023 is planned. A variety of support schemes are in place to facilitate this growth via the Heat Fund, innovation support, a guarantee fund for geothermal district heating, and a feed-in tariff.

The creation of a legal framework to support public-private partnerships help to develop more projects in France. In 2015, the state approved the Energy Transition for Green Growth Law which supports municipalities to access capital from the SAS-LTE (Energy Transition Law) to produce renewable energy. This allows public-private companies to be jointly established between the energy supplier and the local authority.

For example, in 2019 a joint-stock company called Véligéo was created in the city of Vélizy-Villacoublay. It is jointly owned by the city (which has a 20% stake) and Engie (80% stake) to develop the geothermal resource which then feeds directly into the Vélidis district heating network. The supply contract is for 28 years after which ownership transfers to the city or can be issued to another company if the city desires. Véligéo is the very first example of this in the Île-de-France region. The geothermal plant was inaugurated on 7 December 2021.

#### 4.4.7 Technology – Case studies

##### 4.4.7.1 ECOGI

###### **Joint Venture:**

Groupe Electricité de Strasbourg (energy provider): 40%.

Roquette Frères (bio-refinery): 40%.

Caisse des dépôts: 20%.

###### **Region / location:**

Rittershoffen, France

###### **Description:**

The ECOGI geothermal project, located in the Upper Rhine Graben, was initiated in 2011. It is designed to deliver a power of 25 MWth at the “Roquette Frères” bio-refinery in Beinheim in order to cover around 25% of the process heat needed by this industrial site. The drilling site is located in Rittershoffen, 6 km east of Soultz-sous-Forêts, in Northern Alsace, France.

The project is based on a geothermal doublet. The produced heat is delivered through a transport loop to the bio-refinery located in Beinheim, 15 km from the drill site. The heat is then used for industrial processes.

The main aim of ECOGI was to exploit hot fluids (> 160 °C) at around 2 600 m depth at the cover-basement unconformity. Two deep boreholes (2.6 km deep) have been drilled for intersecting deep Triassic sandstone lying on fractured crystalline rocks.

Due to a low natural injectivity index, the first well GRT-1 has been chemically and hydraulically soft stimulated. In this injection well, poststimulation injectivity was improved by a factor 5 leading to industrial flow rate higher than 70 L/s. The soft stimulation program was carried out with no environmental nuisances: there was no

induced seismicity event felt during hydraulic stimulation, and environmental free chemicals were used for dissolving specifically hydrothermal minerals sealing the pre-existing fractures.

Following the encouraging stimulation results, a second borehole has been drilled at Rittershoffen for targeting a production well which was quite successful with artesian flow conditions (> 40 L/s) at high temperature (> 160 °C).

###### **Total budget:**

55M€

###### **Financial instrument/s:**

No European Funding.

National Funding.

- French incentive from the Renewable Heat Fund (18+6 M€).
- Private Investments: 31M€.

###### **Risk insurance:**

Short-term guarantee covering 10% to 60%.

Long-term guarantee.

*Note: The guarantee was provided by the Conseil Régional d'Alsace and SAF Environnement.*

##### 4.4.7.2 Veligeo: Vélizy-Villacoublay, Yvelines (Engie-Solutions, 2022)

The heating network extends over 19 km and serves the equivalent of 12,000 homes.

The use of geothermal energy in the production of heat for the city's network avoids the emission of 22,801 tonnes of CO<sub>2</sub> each year, the equivalent of 15,000 vehicles.

---

This project, developed by ENGIE Solutions and built with Antea Group and other partners, can almost double the productivity of a geothermal reservoir.

The multi-lateral technology has been designed for a new geothermal district heating network in Velizy-Villacoublay, a Paris Basin's municipality eager to cover more than 60% of the heat demand with renewables.

The old network was using 100% fossil energy while there was a geothermal reservoir under the inhabitants' feet. However, this specific area does not have optimal geological properties, showing limited transmissivity and temperature. The challenge was to find a way to produce enough energy to cover the needs of the area, while keeping the project economically viable.

This is why the innovative borehole was designed. The multi-lateral is a technical leap, which allows to cross multiple times a geothermal reservoir. This is the first time

that this method, although a proven concept in Oil & Gas, has been employed in a deep geothermal project. This configuration maximizes the reservoir contact and therefore increases the general flowrate of +80% compared to a conventional doublet. This allows the geothermal plant to provide much more power.

As from 2021, this new geothermal district heating network in Velizy-Villacoublay will cover 60% of the heat demand over the next 28 years. This means satisfying the heating needs of 12,000 houses and saving 22,800 tons of CO<sub>2</sub> per year compared to a gas solution. This project can be easily replicated in municipalities all over Europe and many areas with lower geothermal potential due to poor reservoir quality become new potential targets thanks to this technology. The potential of this technology to reduce emissions in the coming years is massive, considering how untapped geothermal energy still is.



**4.4.7.3 Blagnac, Toulouse Métropole**

2,500 homes and Toulouse-Blagnac airport are connected to the geothermal network.

Bills are on average 20% cheaper than consumers using fossil gas.

3,600 tons of carbon emissions are avoided each year, equivalent to the CO2 emissions of 1,800 cars.

**4.4.7.4 Soultz-sous-Forets, Grand Est**

The power plant provides 2.1 MWe of gross electricity production, of which 1.5 MW is net production on the electricity network.

It produces 10 GWhe annually, corresponding to the equivalent of 2,4000 homes, with an availability of more than 8000 h/year.

It saves 950 t of CO2 per year, which corresponds to the annual emissions of almost 950 cars.

**4.4.8 Key lessons learnt from France to replicate in the Netherlands**

Following table outlines the key learnings we consider to be valuable for the acceleration process with the Netherlands:

Table 9 Key learnings - France

<b>Law on PPP</b>
<b>Heat infrastructure fund</b>
<b>PPP for seismic campaign</b>
<b>Lithium extraction - Special regulations</b>
<ul style="list-style-type: none"> <li>- exclusive research permit, for 5 years, with promise to invest, for the geothermal resources</li> <li>- In parallel another request for the lithium extraction in the same area is needed</li> </ul>
<b>Triple generation:</b>
<ul style="list-style-type: none"> <li>- power/heat/lithium</li> </ul>
<b>Role of Caisse des Depots et Consignations (CdC)</b>
<ul style="list-style-type: none"> <li>- risk insurance, joint ventures</li> </ul>
<b>Heat purchase agreement rule</b>
<b>Drilling design with sub horizontal well design</b>
<b>National roadmap with targets and industrial plan, with an established dialogue: Ministry / stakeholders</b>
<b>Risk insurance</b>
<ul style="list-style-type: none"> <li>- PPP,</li> <li>- short and long term,</li> <li>- national coverage green and brown fields,</li> <li>- shallow and deep</li> </ul>



## 4.5 European Union

### 4.5.1 Priorities for investments

“The right scheme for the right market maturity.” This could be the maxim for financing geothermal energy projects as the

geothermal sector is far from being uniform in terms of maturity and technology readiness across geographical, technology lines and uses.

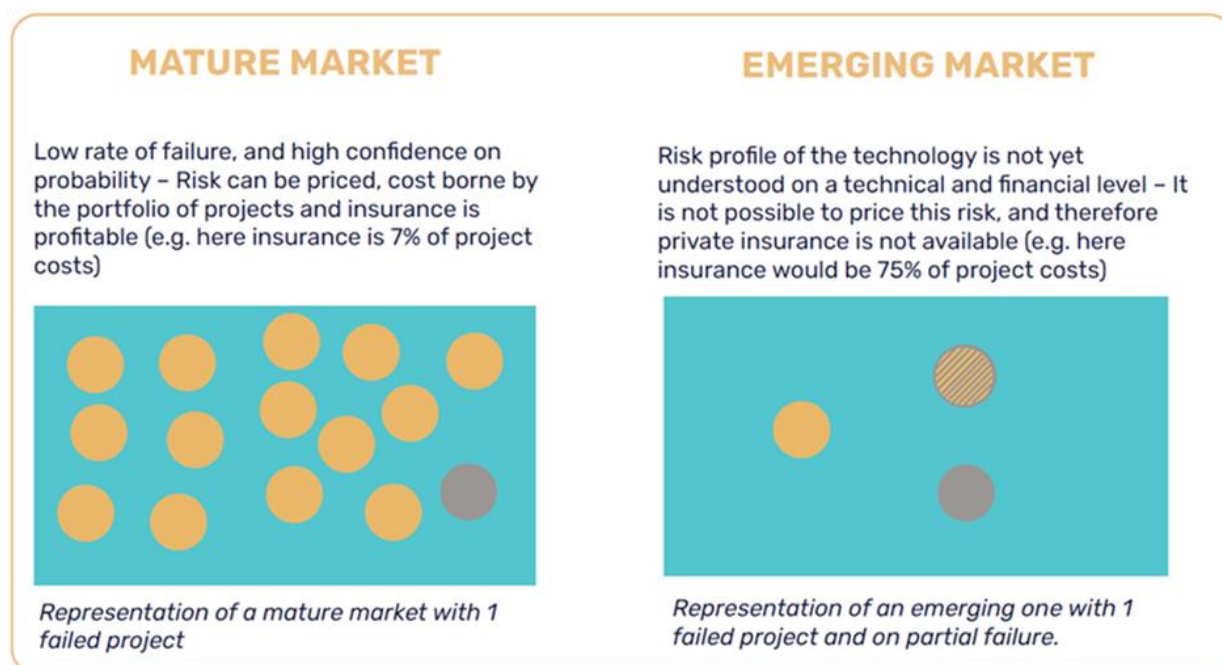

Figure 33: Representation of mature and emerging markets (EGEC, 2024)

As Figure 33 illustrates, to incentivize the scalability of geothermal technologies the exposure to market conditions should not anticipate their market maturity, but rather accompany the technologies towards this goal. Suitable support schemes and financial instruments allow for the cost reductions necessary for a technology to reach the market and for the consolidation of an emerging renewable industry in a market that remains very favourable to incumbent fossil technologies.

The financial and regulatory framework for geothermal energy must articulate four priorities:

- Setting a comprehensive national policy strategy for the development of geothermal energy
- Mitigate the geological risk to facilitate project development;

- Provide incentives for project developers, in particular to facilitate innovation;
- Enable private investors through the right business models and financing schemes.

Based on (Philippe Dumas, 2017) priorities for investments should be:

- Public or private risk insurance
- Investment in infrastructures and operational aid:
  - Investment grants: direct, repayable or convertible
  - Operational aid
  - Tax incentives
  - Zero interest loans
  - Carbon tax
  - Green bonds.

## 4.5.2 Key lessons learnt from EU side to be implemented in the Netherlands

Table 10: Key Learnings – EU level

<b>Public Awareness is still one of the key barriers all over Europe:</b>
<ul style="list-style-type: none"> <li>- Promote awareness of the environmental and economic benefits of geothermal energy to attract interest from investors and financial institutions.</li> </ul>
<b>Geothermal potential varies across EU regions:</b>
<ul style="list-style-type: none"> <li>- Developers should conduct thorough resource assessments to identify the most promising areas for project development.</li> <li>- National exploration campaigns must be launched to achieved a full pan European potential overview</li> </ul>
<b>Local Engagement:</b>
<ul style="list-style-type: none"> <li>- Engage with local communities to garner support for geothermal projects, as community involvement can enhance project financing and social acceptance.</li> <li>- EU frame and guidelines to support local heat plan, crowdfunding, energy communities...</li> </ul>
<b>Financial Public support:</b>
<ul style="list-style-type: none"> <li>- Plays a crucial role in early-stage demonstration projects and risk mitigation. Public funding is essential to bridge the funding gap in the early stages of geothermal project development, where the risks are highest.</li> </ul>
<b>Green Finance Initiatives:</b>
<ul style="list-style-type: none"> <li>- The EU is promoting green finance through initiatives like the European Green Deal and the Taxonomy Regulation. Geothermal projects that meet sustainability criteria may attract green investments and financing.</li> </ul>
<b>Risk-sharing mechanisms:</b>
<ul style="list-style-type: none"> <li>- Can attract private investment and reduce developers' financial burden. Risk-sharing agreements between public and private entities can incentivize private investment by shifting some of the financial risk associated with geothermal projects. Examples include joint ventures, partnerships with energy companies, and insurance schemes. Risk-sharing instruments, such as loan guarantees and insurance products, can help mitigate exploration and drilling risks, making geothermal projects more appealing to investors.</li> <li>- A pan European one or national scheme</li> </ul>
<b>Project Aggregation:</b>
<ul style="list-style-type: none"> <li>- Bundling multiple small-scale geothermal projects can make them more attractive to investors, potentially lowering financing costs.</li> </ul>
<b>Public-Private Partnerships:</b>
<ul style="list-style-type: none"> <li>- Developers can engage in public-private partnerships to share the financial burden and access public funding, which is often available for sustainable energy projects.</li> </ul>
<b>Financial Instruments:</b>
<ul style="list-style-type: none"> <li>- Explore the use of financial instruments like green bonds and green loans, which are designed for sustainable and environmentally friendly projects.</li> <li>- Based also on non-price criteria.</li> </ul>

**Community engagement and alternative financing methods can broaden the funding base:**

- Engaging local communities and leveraging alternative financing tools like crowdfunding can tap into a wider pool of potential investors. Community-based ownership models can foster local support and reduce reliance on traditional financial institutions.

**Technology Innovation:**

- Stay up-to-date with emerging geothermal technologies and consider partnering with research institutions to access funding for pilot projects and innovation. Continued advancements in geothermal technology, such as enhanced and advanced geothermal systems (EGS/AGS) and low-temperature heat recovery, and generalized guidelines / legislations for geothermal project in the EU can increase project feasibility and attract investment. EU-level initiatives like the Horizon Europe program and the Innovation Fund provide grants and loans to support research, development, and demonstration projects.

**Collaboration:**

- Collaboration between public entities, private developers, and research institutions can enhance project financing and knowledge sharing.



# Netherlands





## 5 NETHERLANDS – SNAPSHOT OF TODAY'S STATUS

### 5.1 Current status

As per the Dutch geothermal associations, GeothermieNL, about a quarter of the Dutch heat demand can be met by geothermal energy, or geothermal heat. In greenhouse horticulture, geothermal energy can even meet more than half of the demand for sustainable heat. Geothermal energy in the Netherlands is with about 15 years, a relatively young sector, with a continuous but varying growth. More and more market players are joining with companies having geothermal energy as core business. The next few years are crucial for the

development of geothermal energy in the Netherlands. At present around 36 doublets are operational in The Netherlands, producing over 6,4 PJ of heat every year mainly to heat greenhouses. Focus on residential heating is increasing due its total heat demand potential. However, and especially for the residential sector, the heat demand is not constant over the year or even the day what introduces additional challenges to make projects economical feasible.

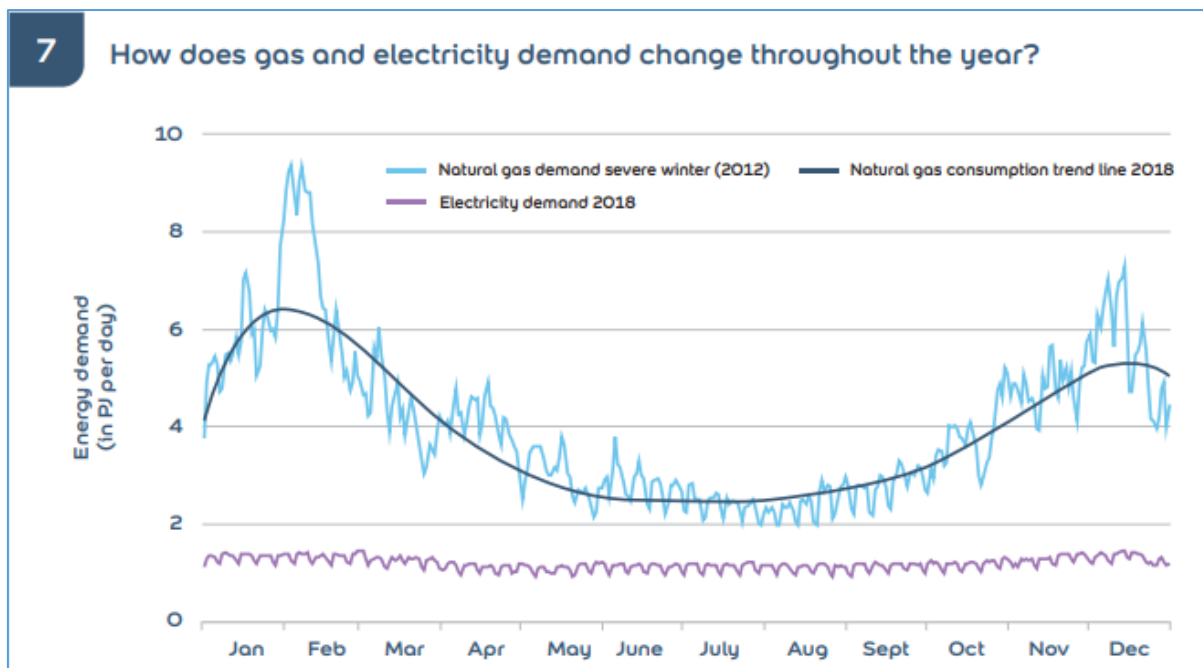

Figure 34. Dutch gas and electricity use over 1 year (EBN, 2020)

### 5.2 EBN

EBN (Energie Beheer Nederland, state owned energy company) and GeothermieNL predecessors, DAGO (Dutch Association of Geothermal Operators) and Platform Geothermie, declared the “Masterplan Geothermal Energy in the Netherlands – A broad

foundation for sustainable heat supply” in 2018. The goal of the masterplan is to expand the share of geothermal energy in the total heat demand from 0.5 percent in 2018 to 5 percent in 2030 and 23 percent in 2050.

Based on the 'Masterplan Geothermal Energy in the Netherlands,' TNO and EBN have been conducting the research project SCAN (Seismic Campaign Geothermal Netherlands) since 2018. The results of the SCAN project enable a better estimation of where potentials for geothermal heat production exist in the Dutch subsurface.

As part of the research project, a 2D seismic survey is being carried out to accurately depict the geological characteristics of the deep subsurface up to a depth of 5 kilometers. Conclusions about the depth and thickness of geothermal reservoirs are expected to be drawn from this information. A part of the SCAN program involves

conducting a series of exploration wells. The purpose of these wells is as well data acquisition with focus near residential areas such as Amsterdam and Utrecht where only little knowledge of the subsurface is present. This data is a crucial supplement to the knowledge already gathered through seismic investigations and data processing.

The drillings enable measurements to be taken to determine the suitability of the intended aquifers for geothermal energy. These additional pieces of information are necessary to obtain a better understanding of the subsurface and to de-risk future geothermal projects.



Figure 35: Role of EBN in the Dutch Geothermal market (EBN, 2024)

### 5.2.1 Socio-economic benefits

EBN prepared a small socio-economic potential mapping report for deep geothermal Energy based on the socio/economic mapping potential inside the DGE Roll-out project in Germany (Timme van Melle (EBN); Jessica Klop (EBN); Gabriela de los Angeles Gonzalez de Lucio (GD NRW), 2022).

It should provide general information to local, regional, and national public authorities, project developers, politicians, and enterprises with heat demand. Appropriate legal advice should be obtained in actual situations. Following conclusions has been made:

---

In general, the socio-economic index is in correlation with the existing geothermal projects. In the area south of The Hague there are many geothermal projects and developments. The areas around Haarlem, Utrecht, Arnhem and 's-Hertogenbosch are relatively underdeveloped. This is due to a lack of subsurface data. This data is being gathered by the SCAN projects which focuses on these areas.

In the Netherlands the heat demand and existing district heating networks are the most important surface driver for geothermal projects. The socio-economic potential index in combination with subsurface mapping, can allow a first prioritization of areas for geothermal development.

It is stated that this report does not replace the own independent research on this topic which is though moved into the section of key success factors.

### 5.3 Financial instruments

Several financial instruments have been utilized to execute geothermal projects in the Netherlands, each with its own advantages and disadvantages. Here are some of the most common:

#### A) Governmental instruments:

**RNES:** In the Netherlands, the Geothermal Guarantee Scheme (RNES Aardwarmte: Regeling nationale EZK en LNV-subsidies voor Aardwarmte ) is a key government support mechanism to de-risk geothermal projects. For a fee, % of project cost, is it possible to insure below expected production results due to formation differences.

#### B) Equity investments:

Equity investments are investments in exchange for a share of ownership in the company or project. This type of investment can be used to provide long-term funding for geothermal projects, as equity holders are not repaid until the project is sold or

refinanced. Equity investors are typically willing to take on more risk than lenders, as they have the potential to reap a higher reward if the project is successful.

#### C) Loans and debt financing:

Loans and debt financing can be used to provide short-term or long-term financing for geothermal projects. Lenders typically require collateral and may charge interest rates based on the perceived risk of the project. This type of financing is often used to finance the construction phase of a project, as the lender can recover its investment from the project's assets if the project fails.

#### D) Public-private partnerships (PPPs):

PPPs are arrangements in which the government and a private partner work together to finance, develop, and operate a geothermal project. This type of arrangement can share the risks and rewards of the project between the government and the private sector. PPPs can be particularly useful for large or complex geothermal projects.

#### E) Structured finance:

Structured finance is a complex financial instrument that can be used to package and sell multiple types of financial products, such as loans, equity investments, and insurance. This can help to reduce the risk of a project and make it more attractive to investors. Structured finance has been used in a few geothermal projects in the Netherlands, but it is not as common as other financing options.

The choice of financial instrument for a geothermal project will depend on a number of factors, including the size and complexity of the project, the availability of government support, the risk appetite of the investors, and the desired level of control over the project.

---

Here are some additional considerations for financing geothermal projects in the Netherlands:

- The Netherlands has a mature financial market with a variety of potential investors.
- The government is supportive of renewable energy projects, including geothermal.
- There is a growing experience with geothermal projects in the Netherlands.
- The Netherlands has a relatively stable political and economic environment.

Despite these advantages, financing geothermal projects can still be challenging. The high upfront costs and long payback periods can make it difficult to attract investors. Additionally, the risks of geothermal projects, such as dry holes and equipment failures, can make insurance expensive.

Despite the challenges, geothermal energy has the potential to play a significant role in the Netherlands' energy mix. As the cost of geothermal technology continues to decline and government support increases, it can be expected to see more geothermal projects developed in the Netherlands in the years to come.

### 5.3.1 Government Incentives

- **SDE++ program:** Provides financial subsidies projects, such as geothermal projects, that meet certain sustainability criteria and contribute to carbon emissions reduction goals. The principle of the SDE++ is to compensate for additional CAPEX over the financial lifetime of the project set at 15 years for geothermal projects. Reality shows that mentioned 15 years is a major factor in the feasibility of projects as project developers, investors and banks aim for a payback period significant shorter to be able to encounter production delays.

- **Research and Development (R&D) funding:** Supports research initiatives to improve geothermal exploration and drilling techniques, enhance energy efficiency, and address environmental concerns.

- **Knowledge Sharing and Collaboration:** Promotes cooperation between stakeholders, including researchers, industry players, and government agencies, to accelerate geothermal development in the Netherlands. Major strength in the Netherlands is public the nlog.nl database with data on wells and seismics.

### 5.3.2 Insurance

Geothermal investments can be insured through the government in the Netherlands in a few ways:

- A) **The Netherlands Enterprise Agency (RVO):** The RVO provides a variety of insurance products for geothermal projects, including:

- *Geothermal Drilling Insurance (RNES):* This insurance covers the geological risks.
- *Geothermal Power Plant Insurance:* This insurance covers the risks associated with operating geothermal power plants, such as equipment failures and power outages.
- *Geothermal Landowner Insurance:* This insurance covers the risks associated with owning land that is used for geothermal projects, such as property damage and liability claims.

- B) **The Netherlands Centraal Beheer (NCW):** The NCW provides a variety of insurance products for geothermal projects, including:



- **Geothermal Exploration Insurance:** This insurance covers the risks associated with exploring for geothermal resources, such as seismic surveys and drilling test wells.
- **Geothermal Project Delay Insurance:** This insurance covers the costs associated with delays to geothermal projects, such as permits, regulatory approvals, and equipment deliveries.
- **Geothermal Environmental Insurance:** This insurance covers the costs associated with environmental remediation and liabilities arising from geothermal projects.

**C) The Netherlands Investment Guarantee Agency (IFG):** The IFG provides investment guarantees for geothermal projects, which can help to reduce the risk of investment and attract more investors.

By providing insurance and investment guarantees, the Dutch government can help to mitigate the risks associated with geothermal investments and make them more attractive to investors. This can help to accelerate the development of geothermal energy in the Netherlands and contribute to the country's transition to a clean energy future.



Here are some additional benefits of insuring geothermal investments through the government:

- **Reduced risk:** Insurance can help to reduce the financial risk associated with geothermal investments, making them more attractive to investors.
- **Improved project viability:** By reducing risk, insurance can make geothermal projects more viable and encourage their development.
- **Enhanced investment certainty:** Insurance can provide investors with certainty that their investments are protected, which can attract more investment.
- **Accelerated project development:** By reducing risk and attracting more investment, insurance can help to accelerate the development of geothermal projects.

## 5.4 Governance

Geothermal energy development in the Netherlands is governed by a combination of national and regional regulations, with the primary responsibility for overseeing these projects resting with the State Supervision of Mines (SodM). The SodM is a government agency tasked with regulating mining activities in the Netherlands, including geothermal projects.

### 5.4.1 Key Regulations Governing Geothermal Projects

**Dutch Mining Act (Mijnbouwwet, besluit & regeling):** This Act provides the overarching framework for mining activities in the Netherlands, including geothermal projects. It defines geothermal energy as a form of mining and outlines the requirements for obtaining permits for geothermal exploration and exploitation.

---

As per July 2023, mining legislation has been changed to adapt more to geothermal requirements with the intention to accelerate. The effect cannot yet be assessed at this moment:

1. Mandatory participation of EBN in geothermal projects to reduce financing requirements and improve sub-surface data sharing,

2. Permitting procedure for geothermal projects has changed using a 'startvergunning' and 'vervolgvergunning' versus 'opsporingsvergunning' and 'winningsvergunning' as common for oil or gas projects. Oil and gas operators typically drill exploration wells followed by development wells where geothermal operators only drill developments wells. Therefore, the process has changed to reduce the risk of not getting license to produce. However, the change does mean that more data before starting to drill is required what may lead to delays and additional costs.

Geothermal Drilling Safety Decree (Geothermische boortechniekbesluit): This Decree outlines specific safety requirements for geothermal drilling operations, including measures to prevent earthquakes, ground subsidence, and contamination of groundwater.

Geothermal Exploration Authorization Decision (Geothermische Opsporingsvergunningbesluit): This Decision provides detailed requirements for

obtaining a geothermal exploration authorization, which is necessary for companies to conduct preliminary investigations to assess the potential for geothermal resources.

Geothermal Exploitation License (Geothermische Exploitatievergunning):

This License is required for companies to extract geothermal fluids from the ground for energy production. It specifies the maximum allowable flow rate and temperature of the fluids, as well as monitoring and reporting requirements.

#### 5.4.2 Regional Involvement

In addition to national regulations, geothermal projects in the Netherlands must also comply with regional planning and environmental permits. For instance, provincial governments play a role in approving site-specific plans and ensuring that geothermal projects are consistent with local zoning regulations and land-use plans.

#### 5.4.3 Financial Incentives and Public Participation

The Dutch government also supports geothermal development through financial incentives and public engagement initiatives. The Energy Investment Allowance (EIA) provides tax breaks for renewable energy projects, including geothermal projects. Additionally, the government encourages public participation in geothermal project planning and decision-making processes to foster community acceptance and minimize potential conflicts.

---

Overall, the governance of geothermal projects in the Netherlands aims to balance the potential benefits of geothermal energy with the need for responsible development that minimizes environmental impacts and ensures public safety. The combination of national regulations, regional involvement, and financial incentives is intended to promote sustainable geothermal energy development in the country.

## 5.5 Social Acceptance

Geothermal energy is a promising renewable energy source with the potential to provide a significant portion of the Netherlands' energy needs. However, the social acceptance of geothermal projects in the Netherlands varies depending on the location and type of project.

### 5.5.1 Positive aspects of geothermal projects:

- Geothermal energy is a renewable energy source that does not emit greenhouse gases or other pollutants.
- Geothermal energy is a domestic energy source that can reduce the Netherlands' reliance on imported energy sources.
- Geothermal energy can be used to heat homes and businesses, which can save money on energy bills.
- Geothermal energy requires only a small footprint and minimal visual.
- Geothermal power can lower electric (peak) power requirements.

### 5.5.2 Negative aspects of geothermal projects:

- Geothermal projects can be expensive to develop and operate.
- There is a risk of induced seismicity.

- There is a risk of contamination of groundwater resources with hazardous materials from shallower or deeper layers if wells are not designed and managed properly.
- Production from subsurface resources has a negative image due to 'Groningen'.
- The required heatnets are not well accepted and are considered expensive.

### 5.5.3 Public opinion

A survey conducted by the Netherlands Environmental Assessment Agency (PBL) in 2019 found that 62% of Dutch people are in favor of geothermal energy, while 38% are opposed. However, there is a significant difference in opinion between urban and rural areas. People in urban areas are more opposed to geothermal energy than people in rural areas.

### 5.5.4 Conditions for social acceptance:

A study by the PBL found that the following conditions are important for achieving social acceptance of geothermal projects in the Netherlands:

- Public involvement in the planning and development of geothermal projects
- Open and transparent communication from project developers
- Demonstration of the environmental and safety benefits of geothermal energy
- Compensation for any negative impacts of geothermal projects.

## 5.6 Permitting

The permitting process for geothermal projects in the Netherlands is complex and involves several government agencies.

---

### 5.6.2 Pre-application phase

- Identification of a suitable location for the geothermal project.
- Perform initial site investigations, including geological and environmental assessments.
- Engage with local stakeholders and obtain their input.

### 5.6.3 Application phase

- Submit a comprehensive application to the Ministry of Economic Affairs and Climate Policy (EZK).
- The application must include detailed technical information, risk assessments, environmental impact studies, and stakeholder engagement reports.
- An independent expert group is appointed to review the application and provide recommendations to the EZK.

### 5.6.4 Decision phase

- The EZK reviews the application, considers the expert group's recommendations, and makes a decision on whether to grant the permit for the geothermal project.
- If the permit is granted, the EZK sets specific conditions and requirements for the project's implementation.

### 5.6.5 Implementation phase

- The project developer must adhere to the permit conditions and comply with all

environmental, safety, and regulatory requirements.

- Regular monitoring and reporting are required to ensure the project's safety and environmental performance.
- The EZK may conduct periodic inspections to verify compliance.

### 5.6.6 Operational phase:

- The geothermal project operates under the permit conditions and regulatory framework.
- The project developer must continuously monitor and report on environmental and safety performance.
- The EZK may conduct regular inspections to ensure continued compliance.

### 5.6.7 Termination or modification phase

- If the project fails to comply with permit conditions or poses unacceptable risks, the EZK may suspend or terminate the permit.
- The project developer may also request modifications to the permit based on new findings or circumstances.

The permitting process for geothermal projects in the Netherlands aims to balance the potential benefits of geothermal energy, such as renewable and sustainable heating, with the need to protect public health, safety, and the environment. The process is designed to ensure that only well-planned and managed geothermal projects are approved and operated.



## 5.7 Legislation

The Dutch government has implemented several policies and regulations to promote geothermal energy development in the country. These measures are aimed at facilitating the exploration, drilling, and utilization of geothermal resources for sustainable heat production.

### 5.7.1 Key Legislation

- **Mining Act (Mijnbouwwet):** This act regulates the extraction of minerals and mineral resources, including geothermal water. It establishes a permit system for geothermal projects and outlines environmental protection requirements.
- **Water Act (Waterwet):** This act governs the management and use of water resources, including groundwater. It sets water extraction limits and requires environmental impact assessments for large geothermal projects.
- **Environmental Management Act (Wet milieubeheer):** This act establishes environmental quality standards and regulates the emission of pollutants from geothermal facilities. It requires projects to obtain environmental permits and adhere to environmental impact assessment procedures.
- **Building Decree (Bouwbesluit):** This decree sets standards for construction materials and activities, including geothermal systems. It ensures that geothermal installations meet safety and environmental requirements.
- **Electricity Act (Energiewet):** This act regulates the electricity market and promotes renewable energy sources. It provides financial incentives for geothermal projects through the Incentive Scheme for Sustainable Energy Production (SDE++ program).

### 5.7.2 Permits and Approvals

- **Geothermal Exploration Permit (Gepl):** Required for initial exploration activities, such as geophysical surveys and drilling boreholes to assess geothermal potential.
- **Geothermal Production License (GWA):** Granted for the commercial extraction of geothermal water for heat production. It specifies production parameters and environmental monitoring requirements.
- **Environmental Permit (MER):** Issued for geothermal projects that may significantly impact the environment. It mandates detailed environmental impact assessments and ongoing monitoring.

### 5.7.3 Environmental Protection Measures

- **Groundwater Monitoring:** Regular monitoring of groundwater levels and quality to ensure the sustainable use of geothermal resources without impacting neighboring water sources.
- **Seismic Monitoring:** Continuous monitoring for potential seismic activity related to geothermal operations to mitigate risks to structures and infrastructure.
- **Wastewater Treatment:** Proper treatment of wastewater generated from geothermal operations to prevent contamination of surface waters or groundwater.

The Dutch government's comprehensive regulatory framework, coupled with financial incentives and R&D support, fosters a supportive environment for geothermal energy development. These measures aim to harness the country's geothermal potential to provide clean, sustainable heat for residential, commercial, and industrial applications.

## 5.8 Technology

Shallower aquifers in combination with heat pumps may be a solution for areas with less favourable deep aquifers.

## 5.9 Hurdles

Geothermal energy, a clean and abundant renewable energy source, holds immense potential to significantly contribute to the global energy mix. However, despite its clear advantages that are explained further down, wider adoption of geothermal energy has been hindered by several challenges respective hurdles:

### 5.9.1 Geological and Technical Challenges

The Netherlands' geology can be complex and variable, which may pose challenges in identifying suitable sites for geothermal development. Unlike other renewable energy investments, the exploration phase for geothermal energy is uncertain and costly. However, in the Netherlands, there is a lot of data available regarding the underground due to past oil and gas explorations.

#### 5.9.1.1 Geothermal Fluid Composition

The composition of geothermal fluids can vary widely, presenting challenges in treating and reusing them. For instance, high salinity or dissolved gases requires specialized handling and equipment, increasing CAPEX.

### 5.9.1.2 Technical Risks during Drilling

The drilling phase can be hampered due to unexpected back sets. This may increase drilling costs significantly. In comparison, wind and solar projects are very predictable in the realization phase. The realization of nuclear power plants are known for unpredictable and excessive cost overruns;

### 5.9.1.3 Technical Expertise and Workforce Development

Drilling deep into the earth to access geothermal resources involves significant technical expertise and equipment.

There is a limited pool of expertise in geothermal energy within the Netherlands, particularly in the areas of resource assessment, drilling technology, and energy conversion. This lack of specialized knowledge can hinder project development and increase costs.

### 5.9.1.4 Competition – people / material / services

The oil & gas industry and recently Carbon storage projects (including EBN) are large players in the NL's. Since people and equipment are very similar the competition is very high. The playfields are varying especially due to varying earnings where especially on the O&G side much higher profits can be made. Demands in both fields need to be full filled. The challenge will be to overcome the big financial differences / costs for the same services at the respective play field.



### 5.9.2 Regulatory Hurdles

The Dutch government is still refining its regulations and policies for geothermal energy development, which can create uncertainty for investors and project developers. A clear and stable regulatory framework is crucial for attracting investment and driving project progress.

### 5.9.3 Financial and Economic Challenges

The initial investment for geothermal projects is high, and the financial viability depends on various factors including energy prices, government incentives, and technological advancements. Securing funding and proving the long-term economic

viability of such projects can be challenging. These costs can be prohibitive for smaller-scale projects or those with uncertain resource potential.

#### 5.9.3.1 High CAPEX

The CAPEX for geothermal electricity is over four times higher than land-based wind and solar and twice compared to hydro or offshore wind. This creates an investment challenge and makes geothermal energy prone to changing interest rates.

If the low-capacity factor of solar is taken into account, it requires M\$3.76 per MW to get the same annual output compared to electricity from geothermal. In other words, geothermal requires 'only' 80% more investment.

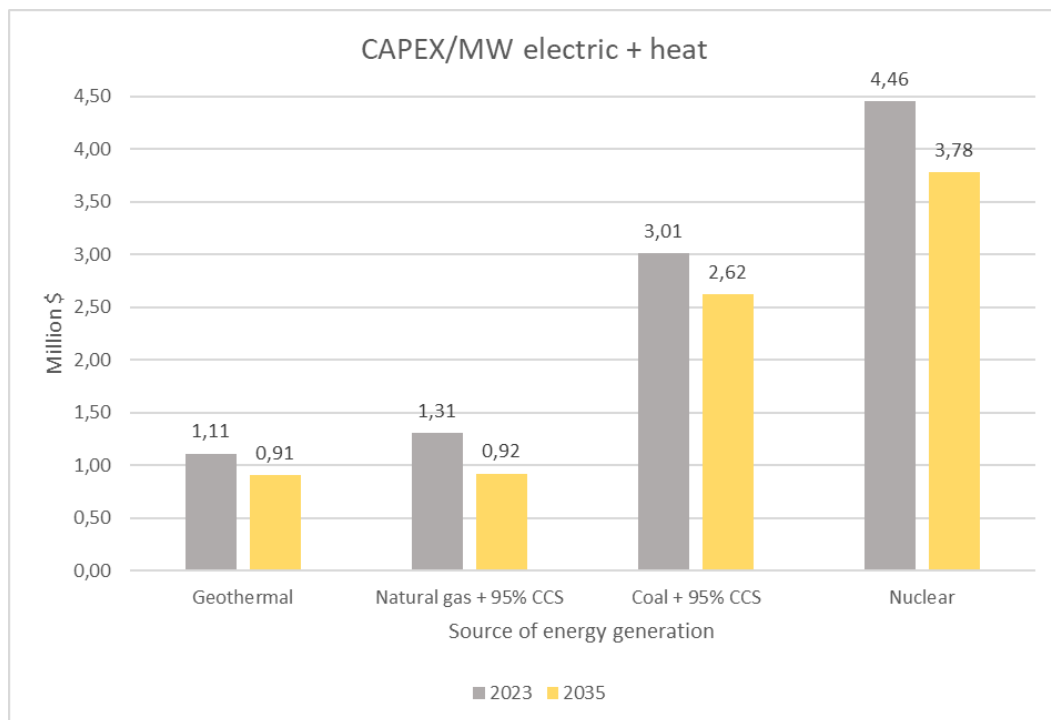

Figure 36: CAPEX/MWh electric (ATB, 2024)

However, combined electricity and heat production turns geothermal energy into the most favorable alternative.

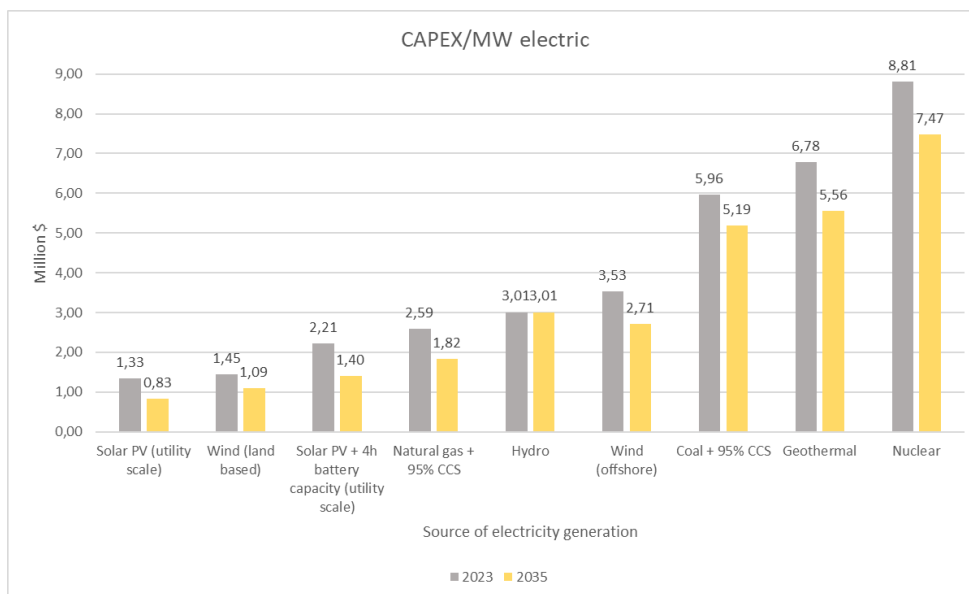

Figure 36: CAPEX/MWh electric (ATB, 2024)

### 5.9.3.2 Subsidy

The current budget given doesn't meet expectations and is apparently too low. Total SDE budget of €8 billion is more than double oversubscribed with a total of €16.3 billion in applications. A lot of subsidies are invested in large subsurface carbon storage (CCUS) projects and although emissions to the atmosphere are reduced, it does delay the actual energy transition and creates additional competition. Therefore, in 2023 there have been 'fences' for the low-temperature heat domain with a budget of €750 million.

Again, this amount is far from sufficient for all geothermal projects. There is little chance that geothermal energy will subsequently be included in the budget outside the gates, amounting to €5.75 billion. Nearly €7.5 billion has already been requested for CCUS alone (with a lower subsidy intensity than geothermal energy).

### 5.9.4 Fragmented Governance

The responsibility for geothermal energy development is divided among various government agencies, including the Ministry of Economic Affairs and Climate Policy (EzK), the Ministry of Infrastructure and Water Management (IenW), and the provinces. This fragmentation can lead to coordination challenges and delays in project approvals.

Better alignment with clear descriptions of roles amongst government bodies as EzK, InvestNL, TNO, RVO and EBN is needed to facilitate project developer and municipalities to start geothermal projects.

### 5.9.5 Environmental Concerns

While geothermal energy is generally clean and sustainable, there are environmental concerns such as the potential for induced seismicity (earthquakes) and the management of geothermal fluids. Addressing these concerns and gaining public acceptance is crucial.



### 5.9.6 Infrastructure and Market Development

Integrating geothermal energy into the existing energy infrastructure and market can be challenging due to the current setup with individual gas heating per house. This includes issues related to the distribution of geothermal heat and ensuring a consistent demand for this energy source. A heat net is required to deliver heat to individual houses and buildings. Building a heat net adds significantly to the CAPEX.

The number of houses connected to a heat net is low and increasing slowly. With

380.000 connections on ~8.1 million houses in Netherlands is the connection rate ~5% what is low compared to Germany and Denmark with respectively rates of 14% and 63%.

In the Netherlands the installation of (offshore) wind power and solar power in combination with relatively large number of electric vehicles and increasing number of residential heat pumps requires major investments on the electricity grid. A crucial heat plan aligned with other electrification developments is needed to prevent long term progress.

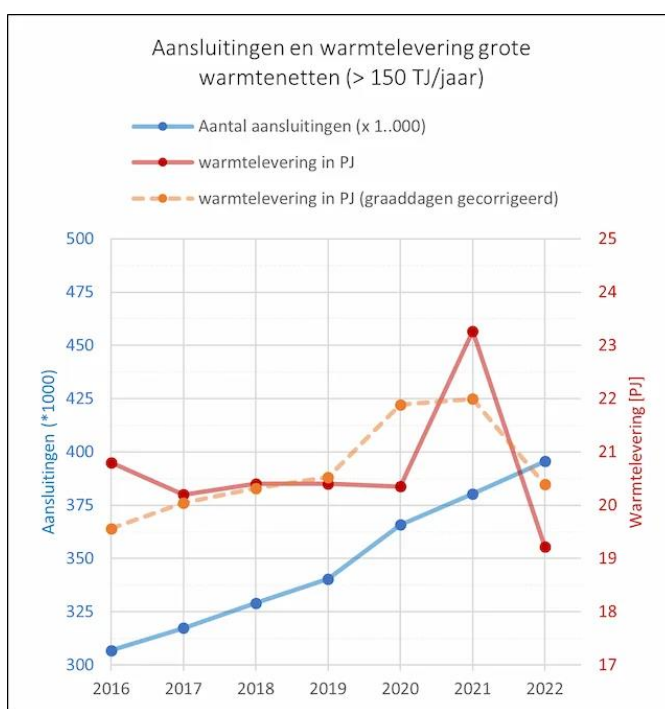

Figure 37. Development of heat net connections in the Netherlands over time (RVO, 2022)

### 5.9.7 Public Awareness and Acceptance

Geothermal energy is still relatively new in the Netherlands, as it is primarily used to heat greenhouses. Drilling and therefore also geothermal energy is associated with seismicity due to Groningen gas production and the lack of response to the earthquakes by the Dutch government. Heat nets are also not well known in the Netherlands and may be associated by high cost and

unreliable heat delivery. Addressing these concerns and promoting public awareness and acceptance is essential for success.

Geothermal projects can face opposition from local communities due to concerns about visual impacts, noise pollution, or the potential for groundwater contamination. Addressing these concerns through community engagement and transparent communication is crucial for gaining social acceptance.

Political leaders promoting geothermal energy is rare compared to other countries while hydrogen attracts a lot of attention.

#### 5.9.8 Land Use Conflicts

Geothermal projects may require access to land for drilling sites and infrastructure which can lead to conflicts with existing land uses or conservation areas. Risk contours (blow-out risks) need to be considered carefully to avoid external safety related conflicts. Careful site selection and planning are essential to minimize such conflicts. Industrial zones may be good alternatives to develop geothermal power plants in urban areas as land prices are lower (less conflict) and projects become less visible.

#### 5.9.9 Visual Impacts

Geothermal power plants and associated infrastructure can have visual impacts on the landscape, particularly in areas with sensitive natural or cultural heritage. Designing projects with minimal visual impact and incorporating them into the surrounding environment can help address these concerns. Moving geothermal plants to industrial zones out of the center of urban areas will add heat net cost but avoids visual impact.

#### 5.9.10 Competition with Other Energy Sources

Geothermal energy competes with other renewable and non-renewable energy sources. The relative cost-effectiveness, reliability, and scalability of geothermal energy compared to these sources can impact its development.

#### 5.9.11 Long-term Sustainability and Monitoring

Ensuring the long-term sustainability of geothermal reservoirs requires careful monitoring and management using field development planning. This includes understanding the replenishment rates of geothermal resources and mitigating any negative environmental impacts.

Overcoming these hurdles requires a comprehensive approach that addresses technical, financial, institutional, and social aspects. The Dutch government, project developers, and the public must work together to develop a clear vision for the heat transition, geothermal energy, invest in research and innovation, streamline regulatory processes, and foster public understanding and support.

## 6 KEY LESSONS LEARNT FROM ABROAD

Geothermal energy has unique advantages over other renewable energy sources and offers key opportunities in the future energy mix especially given the fact that 70 – 80% of the energy consumption in households is used for heating, primarily by burning gas.

In the sense of what can be done to acceleration the usage of geothermal heat, the following sub chapters are summarizing the key learnings from geothermal projects on EU-level and across Germany, Denmark, France we consider to be valuable for the acceleration process within the Netherlands. A summary can be found in **Error! Reference source not found.**

### 6.1 European Union

The European geothermal sector is very dynamic and diverse, and all European countries face challenges to develop the geothermal market from a niche market into a stable market with significant growth. Different business cases, legislation, and public opinion are present due to the different geology, applications, local experience, and exposure to drilling operations. Key barriers include financing to cover high capital investment in potential high-risk projects with varying market conditions and permitting requirements. Socio-economic aspects may be a barrier in some regions regarding public acceptance. Furthermore, the availability of materials, equipment and skilled people have resulted in delays of projects. To overcome the hurdles following key lessons can be drawn:

#### 6.1.1 Politics

European countries are asked to make use of **common EU frameworks and guidelines** to increase the share of renewable heat in local heat planning, create a larger and transparent market and improve (drilling) capacity.

#### 6.1.3 Innovation & Technologies

Stay up to date with emerging **innovative geothermal technologies** and consider

#### 6.1.2 Market & Economy

**Financial public support** plays a crucial role in early-stage demonstration projects and risk mitigation. Public funding is essential to bridge the funding gap in the early stages of geothermal project development, where the risks are highest.

Developers can engage in **public-private partnerships** (ppp) to share the financial burden and access public funding, which is often available for sustainable energy projects.

The EU is promoting **green finance through initiatives** like the European Green Deal, Innovation Fund and the Taxonomy Regulation. Geothermal projects that meet sustainability criteria may attract green investments and financing.

**Risk-sharing mechanisms** can attract private investment and reduce developers' financial burden. Risk-sharing agreements between public and private entities can incentivize private investment by shifting some of the financial risk associated with geothermal projects. Examples include joint ventures, partnerships with energy companies, and insurance schemes. Risk-sharing instruments, such as **loan guarantees and insurance products**, can help mitigate exploration and drilling risks, making geothermal projects more appealing to investors and potentially lower costs. A pan European risk sharing mechanism or individual national schemes should be utilised for further acceleration.

**Collaboration** between public entities, private developers, and research institutions can enhance project financing and knowledge sharing.

partnering with research institutions to access funding for pilot projects and innovation. Continued advancements in geothermal technology, such as enhanced

and advanced geothermal systems (EGS/AGS) and low-temperature heat recovery and generalized guidelines / legislations for geothermal project in the EU can increase project feasibility and attract investment. EU-level initiatives like the Horizon Europe programme and the Innovation Fund provide grants and loans to support research, development, and demonstration projects.

#### 6.1.4 Transfer, Capacity & Acceptance

**Public Awareness** is still one of the key barriers all over Europe. Promotion of awareness of the environmental and economic benefits of geothermal energy to attract interest from investors and financial institutions is one of the keys for acceleration.

The **Geothermal potential** varies across the EU regions. Developers should conduct thorough resource assessments to identify the most promising areas for project development. National exploration campaigns must be launched to achieve a full pan European potential overview.

Engage with **local communities** to garner support for geothermal projects, as community involvement can enhance project financing and social acceptance.

**Project aggregation** by bundling multiple small-scale geothermal projects can make them more attractive to investors, potentially lowering financing costs.

**Community engagement and alternative financing methods** can broaden the funding base: Engaging local communities and leveraging alternative financing tools like crowdfunding can tap into a wider pool of potential investors. Community-based ownership models can foster local support and reduce reliance on traditional financial institutions.

## 6.2 Germany

Geothermal energy is seen as a crucial technology for modernizing the country and ensuring Germany's industrial competitiveness. The Federal Ministry for Economic Affairs and Climate Action (BMWK) emphasized in a position paper (BMWK, 2022) the importance of geothermal energy as a key technology for the energy transition and aims to strengthen the utilization of geothermal energy for heat supply. While shallow geothermal energy has been well developed, the potential of mid-depth and deep geothermal energy is still insufficiently exploited.

The aim is to achieve climate-neutral heat supply for buildings, new construction, and industrial processes by 2045. Measures such as efficiency improvements and the significant expansion of renewable energy sources, including geothermal energy, are necessary. The potential of geothermal energy to improve energy security and replace fossil fuels is there. Based on the wide range of examples of projects across the different states in Germany, the following lessons can be drawn.

### 6.2.1 Politics

A **National roadmap** has been made with 2030 and 2040 targets ("Nationale Erdwärmekampagne"). The use of geothermal energy in Germany shall be expanded widely to contribute in achieving fifty percent of heat being produced in a climate-neutral way by 2030 (as per current coalition agreement). Specifically, in medium and deep geothermal energy, a geothermal potential of 10 TWh is to be developed as far as possible by 2030 hence increasing the current feed-in into heating networks by tenfold (Initial Climate Protection Balance Sheet).



To achieve this, the aim is to initiate at least 100 additional geothermal projects by 2030, connect them to heating networks, and make geothermal energy usable in residential buildings, neighbourhoods, and industrial processes. This should provide a strong impulse (**fly wheel effect**), for further

geothermal projects further develop the technology and prepare the market for the use of geothermal energy. High level politicians frequently visited geothermal sites supporting visibility and acceptance. Eight Measures to achieve the goal have been defined in that context.



Figure 38: Overview – Measures to achieve the “geothermal” goal

The past and currently ongoing projects show that **strong consortia or alliances** on different levels like education, professional and technical between state & municipalities or on private-public partnership (PPP) are elementary to develop together both geothermal drilling and combined district heating on a larger scale.

**Guidelines** for the development and execution of deep geothermal projects are available from various institutions whether they are on state or private level. The variety of the information and a **high amount of accessible & valuable project data** helps project developers to find their way through the complex landscape of the project execution. Even though there is a lot of information available there is still no perfect solution since the conditions from i.e. technical and legislative perspective are still various.

The German federal state has the ambition to set up and improve the existing laws to accelerate and support the transition especially on the heat sector legally and financially. I.e. a triad out of the “Gebäudeenergiegesetz”, Wärmeplanungsgesetz and „Bundes-förderung Effiziente Gebäude“ shall be improved.

Beside supporting schemes on state level such as in North-Rhine Westfalia are under development to enable more urgent action due i.e. lacking knowledge of the constitution in the ground, while realizing that the requirement as per the “Klimaschutzplan 2050” need to be turned in action. The KfW, as one of the leading promotional banks acting on behalf of the national government and the states, together with the private MunichRe are about to set up a **new exploration insurance scheme**.

---

With more than half of the total energy consumption, the heat supply currently contributes significantly to greenhouse gas emissions in Germany. In the building sector, heat predominantly comes from fossil energy sources such as natural gas and oil. This makes Germany dependent on other countries and is not sustainable. Municipalities therefore need to set up a municipal heat planning concept which is covered by the **law for necessity of “heat planning”** (Gesetz zur Wärmeplanung).

Energy providers must re-think their approach to generate heat, and building owners have to consider alternative heating methods. The earlier they can make forward-thinking decisions, the more cost-effective the future energy supply will be. This is where the Heat Planning Act comes in, as a heat plan serves as the local strategic planning tool for the climate-neutral heat supply of the future.

### 6.2.2 Market & Economy

The Bundesverband Geothermie (Geothermal Association) has developed a good position and is very active in promoting geothermal countrywide. The association promotes and informs on many items linked to geothermal projects whether they are financial, regulatory, legally, acceptance etc. This is supportive in the sense of the strategic planning and acceleration process.

External project support is very common, especially for municipal utilities in Germany. Consulting companies like Rödl&Partner, GGSC or Deloitte are constantly working on **incentive systems and financing instruments** which give the municipalities respective their Stadtwerke’s various **options to act on the market**.

Implementing digital accessible data with **maps** covering the geothermal heating potential, the need for heat and optimization of heat nets helps project developers to convey for suitable project locations. This enables location-specific development of geothermal potential and economic feasibility analysis.

The implementation of the **CO2 prevention incentive system** has currently not the strong power it should have. With the goals of the “Klimaschutzplan 2050” in the back this instrument will be a much stronger instrument in the future.

### 6.2.3 Innovation & Technologies

To improve business cases and availability, the current and future geothermal project playground includes the development of **co-generation of heating/cooling and electricity, lithium co-mining and advanced geothermal systems** like the EAVOR™ **closed loop system** and the utilization of **low temperature**. The later is a perfect example for a **demonstration project** where large heat pumps are utilized for district heating which may be applicable for municipalities in the Netherlands due to their comparable geological constitution.

Cities in the south of Germany which start with geothermal energy decades ago, currently undergo important steps to **interconnect/extend and technically improve their heat network. Digitalization and smart** solutions are linked to that process enabling i.e. the intelligent use/distribution of heat throughout the day for connected industry partners and households.

### 6.2.4 Transfer, Capacity & Acceptance

Based on the **law for decarbonization** of heat nets **cities** are including geothermal into their planning especially for heating purposes. Leading in this is Stadtwerke Munich who uses a long-term roadmap to phase out carbon based power plants and built up extensive data set of the underground. Throughout this transition process the **public acceptance to see the need renewable energy** is essential because the required system modifications come with a cost. Throughout workshops, public conferences and media, the appearance of strategic politicians among the many on-going/past geothermal projects became much more visible especially throughout the year. This led to a rise of acceptance.

---

## 6.3 Denmark

Deep geothermal energy development in Denmark is up and running after a difficult start. Several large heating and cooling geothermal projects are in the pipeline and the presence of heatnets is a key enabler to significantly contribute to the country's renewable energy mix. Denmark is experienced in the energy transition since the 1970's oil crisis. Denmark introduced its first Heat Supply Law in 1979. The aim was to become more independent from imported fuels and rising energy prices. Since then, municipalities have been legally obligated to develop **heat plans**. Where possible, heat must be generated through combined heat and power (CHP) production. Heat prices must cover all necessary costs and remain non-profit.

For geothermal energy, Denmark has a favourable sub-surface and well-developed and accepted heat nets in place. Therefore, many projects were started 10 to 15 years ago. However, the failure of the construction of the Viborg Geothermal wells in 2012 led to a major setback to all geothermal projects in development in Denmark. The Danish government has taken proactive steps to support geothermal energy, particularly for district heating.

In 2020, they announced the establishment of a geothermal task force to analyze the socio-economic potential of geothermal heat in district heating and to develop a state aid model to support its cost-effective development. This initiative is part of a broader economic stimulus package focusing on clean energy technologies, reflecting the government's commitment to advancing geothermal energy in Denmark. A clear entry strategy for renewable energy and exit strategy for fossil fuels has been set up.

In March 2023, the Danish Parliament approved a new law that simplifies the regulatory framework for deep geothermal projects, paving the way for the construction of large-scale geothermal plants. In terms of policy and regulation, Denmark's approach to geothermal energy is characterized by

recent changes like the lifting of price regulations for geothermal heat supply. This allows for more flexible pricing agreements between district heating companies and geothermal operators, with a cost ceiling for consumers. Such regulatory changes aim to foster a more conducive environment for geothermal development.

### 6.3.1 Politics

Throughout the **heat net legislation** municipalities must ensure that projects with the highest socio-economic benefit are implemented. The heat supply should, where possible, be generated through combined heat and power (CHP) production. The heat price for consumers must not be higher or lower than the actual heat production costs.

State of Green (State of Green, 2024) acts as a **one-stop-shop** to more than 600 Danish businesses, agencies, academic institutions, experts and researchers. State of Green connects leading Danish players working on the global transition to a sustainable resource-efficient society. State of Green's work is built on international partnerships, solutions, and insights within energy, water, cities, and circular economy. Through decades of experience, Denmark has turned challenges within four areas into opportunities – energy transition, water management, green cities, circular economy.

### 6.3.2 Market & Economy

A high percentage (over 60%) of the Danish households is **already connected to district heating** covering buildings heating & cooling consumption. Over 60% of this heat is provided by renewable sources. Even excess wind energy is being used. Future development will focus on large-scale geothermal plants and sea water heat pumps, that can serve multiple district heating systems and integrate with other renewable energy sources like incineration heat, waste heat from industry or flexible heat systems.

The Danish city of Aarhus is expected to host the country's first large-scale geothermal project, developed by Innargi (founded by A.P.Møller Holding). The project aims to supply up to 20% of the city's district heating demand with geothermal energy. The project is the first one of a series **with at least 10-15 wells per city to significantly improve business case while reducing risk.**



This project is also a very good example of a modern sustainable business model approach where the **initial exploration risk is taken by a private company in return of a long-term (30 year) heat contracts and competitive pricing** by industrializing geothermal heating. Using large scale drilling sequences is common practice in the oil&gas industry to drive down total costs and leverage the learning effect.

Innargi, with shareholders ATP (Denmark's largest pension fund), NRGi (customer-owned utility company) and A.P. Møller holding. Has strong roots in A.P. Møller's previous energy company Maersk Oil. The oil & gas knowledge and experience is leveraged to use a similar approach to cost-effective deliver large scale geothermal projects. It engages as a local company to finance, development, construction and operation of large-scale geothermal heating plants for district heating companies.

Another aspect of the large scale of the Aarhus project is its **visibility** and making geothermal less of a niche and more of a common energy source. A successful large scale project will have a major impact on the local energy transition and create a **fly-wheel effect.**

Large scale projects are of interest to **pension funds** due to the reduced overall

risks over a long period, the local benefits and the sustainable nature of geothermal heat.

### 6.3.3 Innovation & Technologies

Alternative geothermal solutions are also in Denmark being developed. Green Thermal is a Danish company developing a **closed loop** geothermal heat extraction. They use oil and gas industry technology to develop a single well closed loop geothermal solution. They partnered with SONFOR, the utility company of the municipality of Sønderborg, to test this technology in a project aiming at supplying geothermal energy for heating.

### 6.3.4 Transfer, Capacity & Acceptance

There is a strong **commitment** among the local communities and its engagement in the **district heating** approach – suffering cities with fossil fuel-based infrastructures shall be converted to breathing cities with geothermal baseload and 100% renewables.

Denmark has set the ambitious goal of becoming completely independent of fossil fuels by 2050. The Danish capital aims to become carbon-neutral even sooner, by 2025. This reflects the country's strong commitment to sustainability and environmental responsibility, driving forward with innovative energy solutions and policies to reduce carbon emissions and promote renewable energy sources. In this **transformation process of cities** the use of geothermal heat is seen as one of the most environmentally friendly, economically viable sources of clean heating and cooling.

The process is set on five columns – geothermal 1) as a **local** resource, managed and regulated by local authorities provides energy security; 2) is **accessible** in most parts of the country as well as profitable and **competitive** with i.e. fossil fuel alternatives; 3) improves life expectancy, **quality of life** and CO2 savings by replacing dirty fuel; 4) enables the provision of a **stable price** dependant on fixed investment costs; 5) is naturally replenished and **always available** enabling a baseload energy provision.



## 6.4 France

### 6.4.1 Politics

Today, 2 million people are heated by geothermal in France, with 1 million in Paris by geothermal district heating (DH). The French authorities announced in 2023 the plan to multiply this geothermal supply by 5. They published a **National roadmap in February, updated in December 2023**, with clear targets and measures to take. It includes an industrial plan to **ensure workforce** and supply chain is ready, and an established and **regular dialogue** between Ministry and stakeholders. The aim is to make France a leader in geothermal energy in Europe, both in terms of renewable energy production and industrial development by:

- *Geothermal heating networks: +40% of deep geothermal projects launched by 2030.*
- *Geothermal heat pumps: Double the sales of heat pumps from 4.6 TWh in 2023 and 7 TWh of final consumption renewable heat by heat pumps in 2028.*

The Action plan includes eight measures: Reinforce **drilling capacity**, suite **regulatory frame**, **target public and tertiary** buildings, identify resources, upskill local actors and support project developers, incentivize new projects with **innovative business models and project finance**, support in overseas territories and export of French know-how.

**Ministry and stakeholders meet** every two months to **monitor** the implementation of this action plan.

On policy, we can also refer to the creation of a legal **framework to support public-private partnerships** helping to develop more green projects in France. In 2015, the state approved the Energy Transition for Green Growth Law which supports municipalities to access capital from the

Société par Actions Simplifiées - Loi Transition Energetique SAS-LTE (simplified joint-stock company from Energy Transition Law) to produce renewable energy. This allows public-private companies to be jointly established between the energy supplier and the local authority to produce renewable energy.

### 6.4.2 Market & Economy

France is a leading country in Europe in terms of geothermal district heating. Since the 80s, 80 systems have been installed with many still in operation, for an installed capacity of ca 500MWth.

The key support measures which allowed such a development are:

- *The establishment of a **Heat infrastructure fund** (since 2009): the 'fonds chaleur' (heat fund) which will be increased to 820 millions in 2024, instead of 600 in 2023, aims at financing the heat grid infrastructures.*
- *The creation of a **Risk insurance scheme** since the 80s to insure both short- and long-term resource risks. The Short-Term Fund investments worth €198 million were guaranteed for the drilling phase, with €4.7 million paid by the public purse to the Funds, which means that for every €1 paid by the State, €42 of investments were guaranteed. A new scheme is now in place to have a more PPP approach and a national coverage of both green and brown fields. Its financial capacity was increased to 195,6 millions €.*

**Flanking measures** also supported the development of geothermal heat in France: Energy transition tax credit, 0% interest loans, Energy saving certificate scheme, 5,5% VAT for renewable district heating.

In France, we are currently seeing **innovative project financing**. One is the recent **PPP** for a seismic campaign in Toulouse, a green field area. The French energy agency ADEME supports financially the campaign which is realised by ENGIE for the city of Toulouse. Collected data will be used by the project developer to de-risk its geothermal DH in Toulouse, and then BRGM, the French geological survey, will have access to this data publicly financed. Another innovative scheme regards the heat purchase agreement to especially **develop geothermal heat in rural areas**.

In terms of governance, two financial actors play an important role: **ADEME**, the French energy agency involved in funding programmes and the French “**Caisse des Dépôts et Consignations**” (**CdC**), a French institutional investor. The CdC was involved since its start in the risk mitigation scheme. It also participated in a joint venture together with ADEME and private developers for an innovative geothermal plant to supply heat to an industrial partner.

#### 6.4.3 Innovation & Technologies

Recent innovation in France focused on:

**Lithium extraction:** There are several research permits already attributed and some more requested for extracting lithium from the geothermal brine. Research is on extraction technologies and the ecosystem to be created for the refining and the supply to the battery industry. It required an adaptation of the French mining law with a special regulation:

- *Exclusive research permit, for 5 years, with the promise to invest, for the geothermal resources.*
- *In parallel another request for the lithium extraction in the same area is needed.*

**Triple generation:** A developer is looking at the supply of geothermal electricity, heat and lithium to a car manufacturer for its facilities and its cars production.

**Drilling design with sub horizontal well design:** In Paris area where there is already a density of geothermal projects, the geothermal sector is looking at new ways to produce more efficiently. To increase the flow rate, oil & gas technologies have been transferred about sub horizontal well design.

#### 6.4.4 Transfer, Capacity & Acceptance

The objective of the Action Plan is to have an **exponential growth** of geothermal in France. It will require **new manufacturing capacity and workforce**. Measures from the action plan aims at planning this increased production capacity.

Two incidents have damaged the **image** of geothermal in France:

- *Seismicity in Vendenheim with a first seismic event of 2.8 felt in October 2020, then a second one of 3.4 has been reported in December 2020 as induced seismicity for this geothermal project. The (disputed) incident led to a stop of geothermal production and the French States asked INERIS/BRGM to publish a guide on seismicity for the geothermal stakeholders.*
- *In Lochwiller in 2008, during a shallow geothermal drilling for installing geothermal heat pumps systems in a private house, the drilling failed and created an incident: anhydrite swelling damaged more than 100 historic houses in the town of Lochwiller. The drillers contracted to this project didn't have the French qualification to drill.*

The local authority of Alsace put a moratorium on geothermal for 2 years from 2021. guidelines from French authorities about seismicity. The second one forced France to establish a certification scheme for installers. Several **local and regional communication campaigns** have been launched to increase awareness and answer concerns.

## 7 FINAL RECOMMENDATIONS FOR NL

Geothermal energy is increasingly recognized as a viable and sustainable energy source in Netherlands and other European countries, particularly due to several advantages e.g. availability & accessibility, local with minor foreign dependencies, minimal space requirements, being clean & sustainable and stable competitive pricing. Its adoption is influenced by various factors that go beyond mere cost considerations.



In this context, it is crucial to understand both non-price and price criteria that drive the decision-making process for implementing geothermal energy solutions especially in relation, but not limited, to the advantages of geothermal energy. Despite its clear advantages, wider adoption of geothermal energy has been hindered by several challenges and respective hurdles.

Focusing on the non-price and price criteria as well the country specific hurdles in the Netherlands the intensive study of the geothermal market in Germany, Denmark, France and including the approaches from the European Union has, from writers' perspective, helped to figure out the following key recommendations for speeding up geothermal development in the Netherlands.

### 7.1 Policy

The renewed **political support and the publication of an action plan** for geothermal energy development needs to

be fostered. The relevant entities such as government, local authority, industry and financial institutions as well as the public, need to work closely together to enable the stimulation of geothermal energy on larger scale in order to create an industrial sector ensuring provision of energy that is as much as possible independent from imports in terms of supply chain and workforce.

Denmark is an example of how to strategically modify the heat provision through **consistent policies and legislations over long periods of time** (>30 years). In comparison, the geological situation in the Netherlands is favourable. There are over 100 known geothermal wells of which the heat source can be utilized in green and brown fields.



Furthermore, the French action plan and the German geothermal expansion goal until 2030 are good examples, proving mid- and long-term targets, to ensure security for investment. A Dutch **geothermal roadmap with mid (2030) and long term (2040-2050) objectives is required**.

The strategic goal needs to make geothermal to the primary renewable heat source in the overall energy mix. Especially within the heat planning concepts for municipalities it must become an obligation to investigate geothermal heat.

According to French example, an institutional dialogue between authorities and market actors including regular meetings must be established to **monitor the roadmap implementation**. In that sense the collaboration and partnerships among government agencies, industry stakeholders, research institutions, and local communities to share knowledge, address common challenges, and optimize project planning. A good example is the quarterly workshop / talk organized by the “Bundesverband Geothermie” bringing together experienced project participants with interested ones with the goal to attract more and more municipalities, industry partners and so on for geothermal projects.

## 7.2 Regulations

The main aim should be to **remove bureaucratic hurdles, promote efficiency, and establish a more conducive environment for the growth and sustainability** of the geothermal energy sector. The overall goal is to streamline processes, encourage innovation and collaboration, and secure the long-term viability of geothermal projects through supportive policies and frameworks.

The focus is on **overhauling and simplifying mining rules** specific to geothermal energy to create a stable, clear and supportive regulatory framework. This involves:

- *Streamlining and harmonizing the permitting process, making it more digital and user-friendly.*
- *Enhancing coordination and simplifying approval processes by consolidating them under one authority. This includes developing a comprehensive legal framework for approval procedures, digitizing these processes for efficiency, and*

*establishing a specific Geothermal Exploration Law.*

- *Implementing fixed terms for procedures and introducing "fast permitting" areas, where projects with minimal impact and risk can proceed more rapidly.*

**Standardization of technical aspects** of geothermal projects will help to ensure consistency, safety, and efficiency across the board. This not only helps in maintaining quality over long periods but also in reducing complexities and uncertainties in project development and execution.

Introduction of **laws** to facilitate and govern **public** (e.g., municipalities) - **private partnerships** in the development and operation of geothermal plants. This would ensure that both sectors can contribute their strengths and resources effectively, leading to more robust and community-supported projects and a leverage of private finance.

Implementation of regulations to set up **long-term heat purchase agreements** (at least 30 years), drawing inspiration from models in countries like Denmark. This provides stability and financial viability for geothermal projects, ensuring a secure market and consistent demand for the heat produced.

## 7.3 Market & Economy / Financing

Through multifaceted initiatives, the aim should be not just to enhance the operational and financial aspects of the geothermal sector but also to foster a supportive, risk-mitigated, and collaborative ecosystem that propels sustainable and efficient geothermal energy development in all regions on the country.

Promoting a project portfolio approach to **increase the scale of projects**, leading to significant reductions in costs (economics of scale) and shortened lead times (permitting & financing).



Exploration risks are decreased, and novel technologies can be better introduced in large scale projects.

A **collaborative approach among involved governmental, public and financial institutions** such as Invest-NL, RVO, EBN and TNO have or need to get better defined, clear roles, promoting synergy and collaboration are needed. This involves fostering partnerships and a consensus-driven approach among Dutch stakeholders, ensuring aligned efforts, and maximized resource utilization.

The **creation of favourable market and economic conditions** must be emphasized to attract investors. Suitable instruments like participation in drilling, strengthening consortia, and establishing robust insurance solutions for damage compensation are to be desired. This includes:

- *Risk mitigation measures like financial risk mitigation schemes, insurance e.g. lost-in-hole of equipment, project, geological risk insurances.*
- *Prolong project duration to at least 30 years, with options to extend, ensuring stable and long-term operations.*
- *Attractive financial instruments/models/tools to attract private investors, including pension funds and insurances, aligning with the "green deal" ethos, i.e. like the Canadian growth fund.*
- *Establishment of heat infrastructure funding schemes, market incentives, and heat purchase agreements, integrating a CO2 prevention incentive system to support industry partners.*

**Financial arrangements** should be **diversified** in various ways. Private finance and third-party investors should be encouraged to participate more actively in project development and operations. Sectors with high heat demand like greenhouses, hospitals and universities, which can integrate geothermal energy within their processes should be fast-tracked. Various financial models like leasing, to provide flexibility and attract a broader range of investors are worth to be explored.

**Involving municipalities** financially in the yield of geothermal projects, drawing parallels with their participation in photovoltaic and wind power projects, thereby capitalizing on geothermal heat for city needs transformation.

Leveraging the breadth of **tools and support** available from the **EU**, ensures that feasibility is categorized, and resources are optimally utilized.

**Separate funding for drilling and grid financing**, with a dedicated fund to finance the grid, addressing at the same time the risk-time mismatch in cases where a heat network is not yet existent.

## 7.4 Technology development

Through comprehensive measures it is aimed to not only bolster operational capabilities and efficiency but also ensuring that it remains at the cutting edge of sustainable and innovative energy solutions.

One focus could be on **enhancing drilling capacities** by modernizing rig fleets, adopting hands-off and automated approaches to increase efficiency and reduce human intervention. There's a concerted effort to reshape the industry's image through education about and investment in modern, cyber rigs, showcasing the sector as technologically advanced and secure.

**Innovation** is at the forefront of this initiative, with an emphasis on **developing key technologies** that drive the geothermal industry forward. This involves not just technological advancement but also nurturing an ecosystem that supports continuous innovation.



**Local expertise and capacities** in geothermal energy is being cultivated through dedicated training programs, research initiatives and collaborative efforts in technology development. The government plays a pivotal role by supporting research and development, particularly focusing on introducing and nurturing new technologies within the geothermal sector.

A **central knowledge hub or database** is envisioned to consolidate comprehensive information on geothermal resources, project feasibility and best practices. This initiative aims to increase data availability, making vital information accessible for stakeholders, thereby facilitating informed decision-making and project development.

**Digital transformation** is a key strategy, encompassing the streamlining of permitting processes, network control, and the introduction of digital twins for wells. This digitization drive is expected to enhance operational efficiency, reduce delays and foster a more dynamic and responsive industry framework.

The strategy also includes **advocating for co-generation and co-mining** initiatives, where geothermal projects are integrated with other energy or mining operations. This not only maximizes resource utilization but also opens avenues for innovative,

sustainable, and economically viable energy solutions.

Through these comprehensive measures, the sector aims to not only bolster its operational capabilities and efficiency but also ensure that it remains at the cutting edge of sustainable and innovative energy solutions.

## 7.5 Visibility

Like Munich, Paris and Aarhus, **focus on areas with large impact** by developing large scale projects coupled with extensive heat nets. This will create more visibility, public acceptance and can act as fly wheel.

To bolster **stakeholder acceptance and engagement** in geothermal projects, a multi-faceted approach is recommended. **Information transparency** is a key aspect, i.e. with data project evolution, on performance or heat pricing made readily available on websites. Additionally, **community engagement** is emphasized through **local information sessions**, facilitating a direct dialogue between stakeholders and project managers. This approach is further enriched by fostering **cooperation and exchange of best practices among cities and politicians**.



Recognizing the significance of local interest, the strategy involves the **early involvement of municipalities** in the approval process, ensuring their interests and concerns are considered from the outset. This **commitment to social acceptance** extends to **prioritizing sustainability and innovation** in project operations.

Environmentally friendly drilling techniques are employed to minimize the ecological footprint, and co-generation opportunities are promoted to maximize energy efficiency.

Furthermore, the strategy acknowledges the importance of community integration and support. This is manifested in initiatives aimed at **fostering local employment, enhancing skills development, and establishing for example community benefit funds.**

These funds are designed to ensure that the local populace directly benefits from the projects, fostering a sense of ownership and support for the initiatives. Through these comprehensive measures, the approach seeks to build a robust foundation for sustainable, community-supported geothermal projects.

## 7.6 Heat nets / District heating

The **construction of heat nets** should be accelerated according to the Danish model. Well established district heating systems are essential for decarbonizing the urban environment by facilitating the distribution of heat from various sustainable origins, including geothermal. Multiple suppliers will introduce competition and ensure fair pricing. Secondly, heat nets are the obvious solution to replace the natural gas grid in covering peak heat demands.

## 7.7 International cooperation

Netherlands is leading in **underground thermal storage** and this needs to be exported to support i.e. local industries to become technology leaders in that field. The experience on how to make effective use of the (shallow) thermal reservoirs and abandoned mines is a business opportunity.

The experiences throughout drilling, testing and maintaining geothermal wells for green house-applications for over **15 years** are unique and should be promoted. Especially the experience to drill on small sites respectively tight site conditions led to

knowledge gathering that may help other interested parties to set out the right conditions for drilling in municipal areas.

In the Netherlands, the Geothermal Guarantee Scheme (**RNES Aardwarmte: Regeling nationale EZK en LNV-subsidies voor Aardwarmte**) is a key government support mechanism to de-risk geothermal projects. For a fee, % of project cost, is it possible to insure below expected production results due to formation differences. The **knowledge** around the applicability of this scheme should be exported to countries that are looking for adequate risk mitigation schemes. At the same time, the scheme could be expanded to cover exploration risks in Dutch focal areas to avoid projects delaying while waiting for SCAN wells.

## 8 LIST OF FIGURES

Figure 1: Geothermal systems archetypes. Illustration taken from (EAPOSYS, 2023) adapted from (Abesser, 2020) BGS.....	9
Figure 2: Installed capacity and capacity under development for electricity in 2022 (MW).....	12
Figure 3: Mapping of main geothermal district heating and cooling reservoirs with existing systems and temperature.....	13
Figure 4: Number of geothermal district heating and cooling, operating and in development (largest and emerging European markets) .....	14
Figure 5: Cascading of geothermal heat. Starting from electricity using the highest temperature down to fish farms using the lowest temperatures (Héctor Aviña-Jiménez, 2022) .....	14
Figure 6: Mechanisms for funding geothermal energy projects at different stages of projects development (elaborated by EGEC, updates 2023) (Philippe Dumas, 2017) .....	16
Figure 7: Support schemes for Geothermal adapted to technology maturity (EGEC, 2024) ...	16
Figure 8: Process of risk management and scope/frame of insurance .....	22
Figure 9: Overview – Measures to achieve the “geothermal” goal (BMWK, 2022).....	28
Figure 10: Results (TIGER) – CON .....	39
Figure 11: Results (TIGER) – PRO .....	40
Figure 12 Permitting process – Germany (Rödl & Partner, 2023).....	40
Figure 13 : Time line for a geothermal project among all phases (example) (TSB - Transferstelle Bingen, 2005) .....	41
Figure 14 Time line for a geothermal project among all phases (example) (GTN, 2017) .....	41
Figure 15: Legislation / Permitting Process (GER) (ASUE, 2011) .....	43
Figure 16: Market development (Ministerium für Wirtschaft, Industrie, Klimaschutz und Energie des Landes NRW, 2023).....	46
Figure 17: Existing instruments (Ministerium für Wirtschaft, Industrie, Klimaschutz und Energie des Landes NRW, 2023).....	47
Figure 18: Funding from idea until exploration (Ministerium für Wirtschaft, Industrie, Klimaschutz und Energie des Landes NRW, 2023).....	47
Figure 19: Anreizsysteme & Finanzierungslösungen (Rödl&Partner, 2023) .....	50
Figure 20: Ergebnis der Studie (Leibniz-Institut für Angewandte Geophysik (LIAG), 2013) ...	52
Figure 21: Sortierung der Relevanzsummen nach Cluster-Ranking (Leibniz-Institut für Angewandte Geophysik (LIAG), 2013).....	52
Figure 22: Optionen für Finanzierungsinstrumente (BDEW, VKU, Deloitte, 2023).....	55
Figure 23: Timeline - The Danish renewable energy journey - Key milestones in Denmark and Ørsted's transition to green energy (State of Green, 2021) .....	57
Figure 24: Share of citizens served by district heating in percent (Euroheat & Power, 2017) .	60
Figure 25: Heating network areas in the Greater Copenhagen area connected by transport networks (as well as potential expansion areas - here still without Køge, which would extend from Solrød to the south) (Radloff, 2015) .....	61
Figure 26: Heat sources for DH in selected countries (in GWh) (EuroHeat & Power, 2023) ...	70
Figure 27: Innargi website – What we do (INNARGI, kein Datum).....	74
Figure 28: Overview of geothermal installations & potential resources in France (BRGM, 2024) .....	77
Figure 29: French Risk Mitigation Scheme.....	81
Figure 30: Future geothermal development in France .....	82
Figure 31: Risk zones (new RMS in France).....	83
Figure 32: Probabilistic plots depending of the level of risk in each zone (new RMS in France) .....	83
Figure 33: Representation of mature and emerging markets (EGEC, 2024).....	92
Figure 34. Dutch gas and electricity use over 1 year (EBN, 2020).....	96
Figure 35: Role of EBN in the Dutch Geothermal market (EBN, 2024).....	97
Figure 36: CAPEX/MWh electric (ATB, 2024) .....	106
Figure 37: CAPEX/MWh electric (ATB, 2024) .....	107



Figure 38. Development of heat net connections in the Netherlands over time (RVO, 2022) 108  
Figure 39: Overview – Measures to achieve the “geothermal” goal ..... 112  
Figure 40: Energy transition fund (example) (BDEW, VKU, Deloitte, 2023)..... 159

## 9 LIST OF TABLES

Table 1: Types of private investors and projects supported.....	17
Table 2: Coalition Agreement – Acceleration agreement between federal government and state (MPK, Bundeskanzler, 2023) .....	34
Table 3: Key learnings - Germany.....	54
Table 4: Examples of entry and exit strategies for energy companies, as experienced in Denmark over the last 10-15 years in particular (State of Green, 2021) .....	58
Table 5: Key facts – Thisted Geothermal power plant (GEODH, 2014).....	71
Table 6: Geothermal (ground-source) heat pumps as of 31 December 2019 (Mathiesen, 2021) .....	72
Table 7: Key learnings – Denmark .....	75
Table 8: Permitting process in France .....	85
Table 9 Key learnings - France .....	91
Table 10 Key Learnings – EU level .....	93
Table 11: Conclusions – Geological risk mitigation .....	132
Table 12: Conclusions - regulatory framework & permitting processes .....	132
Table 13: Conclusions - Long-term feed-in tariffs and price support.....	133
Table 14: Conclusion – Risk & insurance .....	133
Table 15: Conclusion - Community Engagement and Support .....	134
Table 16: Conclusion - Technology .....	134
Table 17: Centralized measures – licence applications.....	144
Table 18: Local authority collaboration – licence applications .....	144
Table 19: Overall Strategies - – licence applications .....	145

## 10 REFERENCES

Abesser. (2020).

American Clean Power (ACP). (2023, 12 01). *Natural Gas*. Retrieved from <https://cleanpower.org/>

Association Française des Professionnels de la Géothermie. (2021). *2021 France Country Report*. IEA Geothermal.

ASUE. (2011). *Tiefe Geothermie*.

ATB. (2024). Retrieved from <https://atb.nrel.gov/electricity/2023/geothermal>

BDEW, VKU, Deloitte. (2023). *Kapital für die Energiewende*.

Bloomberg. (2023, 03 02). *Denmark Gives Green Light to Drill for Geothermal Heat*. Retrieved from <https://www.bloomberg.com/news/articles/2023-03-02/denmark-gives-green-light-to-drill-for-geothermal-heat?leadSource=uverify%20wall>

BMWK. (2020). *Richtlinien zur Förderung von Maßnahmen zur Nutzung erneuerbarer Energien im Wärmemarkt, Marktanreizprogramm für erneuerbare Energien im Wärmemarkt (MAP)*. Bundesanzeiger.

BMWK. (2022). *Eckpunkte für eine Erdwärmekampagne - Geothermie für die Wärmewende*.

BMWK. (2022, 11 11). *Geothermie für die Wärmewende – Bundeswirtschaftsministerium startet Konsultationsprozess*. Retrieved from <https://www.bmwk.de/Redaktion/DE/Pressemitteilungen/2022/11/20221111-geothermie-fuer-die-waermewende.html>

BRGM. (2024).

Bundesministerium für Umwelt, N. u. (2021, 06 24). *Deutsche Klimaschutzpolitik*. Retrieved from <https://www.bmwk.de/Redaktion/DE/Artikel/Industrie/klimaschutz-deutsche-klimaschutzpolitik.html>

Bundesministerium für Umwelt, Naturschutz und nukleare Sicherheit (BMU). (2016). *Klimaschutzplan 2050*.

Bundesverband Geothermie. (2023, 11 06). *FÖRDERMITTEL FÜR GEOTHERMIEFORSCHUNG MÜSSEN DEUTLICH ERHÖHT WERDEN*. Retrieved from [https://www.geothermie.de/aktuelles/nachrichten/news-anzeigen?tx\\_news\\_pi1%5Baction%5D=detail&tx\\_news\\_pi1%5Bcontroller%5D=News&tx\\_news\\_pi1%5Bnews%5D=1468&cHash=14043257639105df093db9d5d44658ab](https://www.geothermie.de/aktuelles/nachrichten/news-anzeigen?tx_news_pi1%5Baction%5D=detail&tx_news_pi1%5Bcontroller%5D=News&tx_news_pi1%5Bnews%5D=1468&cHash=14043257639105df093db9d5d44658ab)

Bundesverband Geothermie. (2023, 11 09). *PRIVILEGIERUNGSTATBESTAND IM BAUGESETZBUCH FÜR GEOTHERMIE KOMMT*. Retrieved from <https://chat.openai.com/c/89ef3e38-24ef-44d6-8457-c15c2dcbf203>

Bundesverband Geothermie. (2023, 10). *Stand der Forschung und Forschungsbedarf in der Geothermie*. Retrieved from [https://www.geothermie.de/fileadmin/user\\_upload/Bibliothek/Downloads/Forschungsbedarf\\_2023.pdf](https://www.geothermie.de/fileadmin/user_upload/Bibliothek/Downloads/Forschungsbedarf_2023.pdf)

Bundesverband Geothermie e.V. (2023). *Klimaneutrale Wärme aus Geothermie 2045*.

businesswire. (2020, 07 28). *Denmark Geothermal Energy Market - Growth, Trends & Forecasts, 2020 - ResearchAndMarkets.com*. Retrieved from <https://www.businesswire.com/news/home/20200728005439/en/Denmark-Geothermal-Energy-Market---Growth-Trends-Forecasts-2020---ResearchAndMarkets.com>

CDU/CSU. (2023, 09 05). *Potenziale der Geothermie nutzen – Hürden abbauen, Risiken minimieren*. Retrieved from <https://dserver.bundestag.de/btd/20/082/2008210.pdf>

- CPH post. (2014, 10 24). <https://cphpost.dk/2014-10-24/news/drilling-for-geothermal-energy-too-economically-risky/>.
- Danish Energy Agency. (2017). *Geothermal energy 2017*. Retrieved from <https://europeangeothermalcongress.eu/wp-content/uploads/2019/07/CUR-09-Denmark.pdf>
- Department of Engineering Science, University of Auckland, New Zealand. (2012). *EFFICIENCY OF GEOTHERMAL POWER PLANTS: A WORLDWIDE REVIEW*.
- Deutschlandfunk. (2023, 11 15). Retrieved from <https://www.deutschlandfunk.de/bundesregierung-verhaengt-ausgabensperre-fuer-klimafonds-100.html>
- Directorate-General for Climate Action (European commission). (2023, 11 06). *The EAVORLOOP story: harnessing the Earth's energy for a greener transition*. Retrieved from [https://climate.ec.europa.eu/news-your-voice/news/eavorloop-story-harnessing-earths-energy-greener-transition-2023-11-06\\_en](https://climate.ec.europa.eu/news-your-voice/news/eavorloop-story-harnessing-earths-energy-greener-transition-2023-11-06_en)
- EAPOSYS. (2023).
- EBN. (2020). *Energy in Numbers 2020*. Retrieved from <https://www.energiein nederland.nl/wp-content/uploads/2020/02/EBN-INFOGRAPHIC-2020-ENG.pdf>
- EBN. (2024). *Rol EBN bij aardwarmteprojecten*. Retrieved from <https://www.ebn.nl/aardwarmte/rol-ebn-in-aardwarmteprojecten/>
- EGEC. (2021). *Geothermal Energy Use, Country Update for Denmark*.
- EGEC. (2024).
- energie samen. (2024, 01 12). *Alles over energiecoöperaties*. Retrieved from <https://energiesamen.nu/alles-over-energiecooperaties>
- Energy Supply. (2017, 09 22). <https://cphpost.dk/2014-10-24/news/drilling-for-geothermal-energy-too-economically-risky/>.
- Engie-Solutions. (2022, 10 24). Retrieved from <https://www.engie-solutions.com/fr/presse/veligeo>
- Euroheat & Power. (2017). *Country by country*.
- EuroHeat & Power. (2023).
- European Commission – DG Energy A.4. (2020). *Final Report Cost of Energy (LCOE)*.
- European Parliament Research Service. (2023). *Geothermal energy in the EU*.
- FIH Partners. (2022, 03). *FIH Partners advises Innargi, a leader in Geothermal energy, on a capital raise with ATP and NRGi as investors*. Retrieved from <https://www.fihpartners.com/capital-raise-for-innargi-a-leader-in-geothermal-energy/>
- Fournier, S. (2024, 01 17). *Denmark's renewable energy progress*. Retrieved from <https://www.araner.com/blog/denmarks-renewable-energy-progress>
- Fraunhofer, GFZ, KIT, UFZ. (2022, 02 02). *Roadmap tiefe Geothermie für Deutschland*.
- GEODH. (2014). *DEVELOPING GEOTHERMAL DISTRICT HEATING in EUROPE*.
- Geothermal Technologies Office's (GTO). (2024, 01). Retrieved from <https://www.energy.gov/eere/geothermal/geothermal-faqs>
- geothermie nederland. (2022). *Geothermie - In de startblokken voor sterke groei*.
- GTN. (2017). <https://www.gtn-online.de/media/2096/20171026-mafa-flyer.pdf>.
- GTN. (2017, 10 26). *Wärmeversorgung mittels tiefer Geothermie*.



- HasePost. (2023, 11 11). *Verband kommunaler Unternehmen fordert schnellere gesetzliche Rahmenbedingungen für Geothermie.*
- Héctor Aviña-Jiménez, E. P.-G.-F. (2022, 11 18). General Information on Geothermal Energy.
- Industry Europe. (2022, 01 19). *Denmark to host EU's largest geothermal heating plant in Aarhus.* Retrieved from <https://industryeurope.com/sectors/energy-utilities/denmark-to-host-eus-largest-geothermal-heating-plant-in-aarhus/>
- INNARGI. (2024, 01). Retrieved from [https://www.linkedin.com/posts/innargi\\_renewableenergy-aarhus-renewableenergy-activity-7138837119199842304-CiyW?utm\\_source=share&utm\\_medium=member\\_android](https://www.linkedin.com/posts/innargi_renewableenergy-aarhus-renewableenergy-activity-7138837119199842304-CiyW?utm_source=share&utm_medium=member_android)
- INNARGI. (2023, 11 20). *Green milestone for Denmark: Geothermal drilling has started in Aarhus.* Retrieved from <https://innargi.com/green-milestone-for-denmark-geothermal-drilling-has-started-in-aarhus/>
- INNARGI. (2024). *Project: Aarhus, Denmark.* Retrieved from <https://innargi.com/project/aarhus/>
- INNARGI. (n.d.). *What we do.* Retrieved from <https://innargi.com/what-we-do/>
- INNARGI. (n.d.). *Who we are.* Retrieved from <https://innargi.com/who-we-are/>
- Innovative Energie Pullach. (2023, 04 27). *Potentiale einer großräumigen Vernetzung.* München.
- International Energy Agency (IEA). (2023, 12 01). <https://www.iea.org/>. Retrieved from World Energy Outlook 2020.
- International Energy Agency (IEA). (2023). <https://www.iea.org/regions/europe>.
- International Hydropower Association (IHA). (2023, 12 01). *Hydropower: The Facts.* Retrieved from <https://www.hydropower.org/>.
- Landkreis Uelzen. (2018, 08 17). *KfW-Darlehen in Verbindung mit Tilgungszuschuss des Bundes für Tiefengeothermie beantragen.* Retrieved from <https://www.landkreis-uelzen.de/home/landkreis-uelzen-politik-verwaltung-wirtschaft/was-erledige-ich-wo.aspx/oeid-/anliegenid-411540978/>
- Leibniz-Institut für Angewandte Geophysik (LIAG). (2013). *Tiefe Geothermie - Grundlagen und Nutzungsmöglichkeiten in Deutschland.*
- Mathiesen, A. (2021). *Geothermal Energy Use, Country Update report for Denmark.*
- Ministerium für Wirtschaft, Industrie, Klimaschutz und Energie des Landes NRW. (2023, 11 10). *Wärmewende durch Geothermie in NRW.*
- Mizuho Bank, Ltd. (2018). *Overview of Project Finance for Geothermal Power Projects.*
- MPK, Bundeskanzler. (2023). *Pakt für Planungs-, Genehmigungs- und Umsetzungsbeschleunigung.*
- National Renewable Energy Laboratory (NREL). (2023, 12 01). <https://www.nrel.gov/analysis/life-cycle-assessment.html>. Retrieved from Life Cycle Greenhouse Gas Emissions of Energy Sources.
- Office of energy efficiency & renewable energy. (2024, 01 08). Retrieved from <https://www.energy.gov/eere/geothermal/geothermal-faqs>
- Our World in Data.* (2022, 06 22). Retrieved from <https://ourworldindata.org/land-use-per-energy-source>
- Our World in Data.* (2024, 01 08). Retrieved from <https://ourworldindata.org/grapher/levelized-cost-of-energy>
- Philippe Dumas, T. G. (2017). *Financing geothermal projects in Europe: An overview of the available instruments.*

- Platform Geothermie, DAGO, Wamtenetwerk, EBN. (2018). *Masterplan Aardwarmte in Nederland*.
- Radloff, R. (2015). *Fernwärme im Großraum Kopenhagen*.
- Regierungspräsidium Darmstadt, Hessisches Landesamt für Umwelt und Geologie. (2011). *Leitfaden Tiefengeothermie (Planung & Durchführung von Projekten) Bergrechtlicher Teil*.
- Richter, A. (2022, 01 14). *Think Geoenenergy*. Retrieved from <https://www.thinkgeoenenergy.com/new-price-regulation-brings-hope-for-geothermal-heating-push-in-denmark/>
- Robin Renoth, E. B. (2023). Social acceptance of geothermal technology on a global view: a systematic review. *Energy, Sustainability and Society*, 19.
- Rödl & Partner. (2023, 04 27). Finanzierung und Versicherung von Geothermie-Projekten. München.
- Rödl&Partner. (2023). Geothermie - Gamechanger für die Wärmewende?
- RVO. (2020). *Heating and Cooling Potential Analysis*.
- RVO. (2022). *Duurzaamheidsrapportage*.
- State of green. (2016, 02 16). *New White Paper on District Energy*. Retrieved from <https://stateofgreen.com/en/news/new-white-paper-on-district-energy/>
- State of Green. (2021). *FROM BLACK TO GREEN: A DANISH SUSTAINABLE ENERGY GROWTH STORY*.
- State of Green. (2023). *New rules pave the way for large-scale geothermal plant in Denmark*. Retrieved from <https://stateofgreen.com/en/news/new-rules-pave-the-way-for-large-scale-geothermal-plant-in-denmark/>
- State of Green. (2024, 01 12). *Your entry point to Denmark's green transition*. Retrieved from <https://stateofgreen.com/en/>
- Statista. (2023, 01). <https://www.statista.com/statistics/800217/eu-power-production-by-fuel/>.
- Statista. (2024, 01). Retrieved from <https://www.statista.com/statistics/183680/us-average-capacity-factors-by-selected-energy-source-since-1998/>
- SWM. (2022, 06 14). Genehmigung von Tiefengeothermieanlagen - Praxisbericht München.
- The Hague Centre for Strategic Studies. (2023). *Olie en gas tijdens de energietransitie*.
- Timme van Melle (EBN); Jessica Klop (EBN); Gabriela de los Angeles Gonzalez de Lucio (GD NRW). (2022). *Socio-economic potential mapping for Deep Geothermal Energy*.
- TSB - Transferstelle Bingen. (2005). *Leitfaden für Geothermieprojekte im rheinland-pfälzischen Teil des Oberrheingraben - Teil 1*.
- U.S. Energy Information Administration (EIA). (2023, 12 01). <https://www.eia.gov/todayinenergy/index.php?tg=%20geothermal>. Retrieved from Geothermal Power.
- U.S. Energy Information Administration (EIA). (2023, 12 01). *Petroleum*. Retrieved from <https://www.eia.gov/petroleum/>
- Wikipedia. (2024). Retrieved from [https://en.wikipedia.org/wiki/Levelized\\_cost\\_of\\_electricity](https://en.wikipedia.org/wiki/Levelized_cost_of_electricity)
- World Coal Association. (2023, 12 01). *Coal: Powering the World*. Retrieved from <https://www.futurecoal.org/coal-facts/>
- World Resources Institute (WRI). (2023, 12 01). *Biomass*. Retrieved from <https://www.energy.gov/eere/bioenergy/biomass-resources>.

## 11 APPENDICES

### 11.1 Appendix 1: Lessons learned

lesson / observation	benefits / opportunities	remark(s)
Large scale projects (>10 wells)	<p>Significant less lead-time (permitting &amp; financing) and lower cost per MWh installed (economics of scale).</p> <p>Facilitates innovation / novel technologies.</p> <p>Better subsurface knowledge (decreased exploration risk) for better long term planning (field development plan)</p> <p>Better visibility (fly-wheel-effect)</p>	<p>Large projects will require higher investments. Longer heat contracts and risk mitigation schemes can facilitate this. Combining projects (within preset criteria) maybe an option to scale up but may not give the FDP opportunity.</p> <p>Especially relevant in a high impact area.</p>
Enhancing drilling capacities, ensure workforce (plus the chain that is involved in service & material contribution)	Modern fit-for-purpose rigs with well-trained staff perform better what will lead to lower cost and lower risk	A stable drilling market with long term planning using roadmaps will enable contractors and service companies to invest in people and equipment. Modern drilling equipment will improve the image of drilling rigs and will become a more attractive workplace.
Long-term (>30 year) heat contracts & licensing	<p>Longer commitments - de-stress projects financially resulting in improved -&gt; business cases, optimised life-cycle costs and a stable (local) energy pricing.</p> <p>Geothermal heat delivery becomes more in line with heat net and housing life times.</p>	<p>Long-term stable projects become more interesting for investors such as pension funds.</p> <p>Long term projects providing clear local benefits such as stable energy supply and jobs is interesting for municipalities to participate in.</p>
EU technical guidelines	Standardisation of training, equipment and well design requirements across EU creates a larger, more transparent market resulting in lower project risks and increased drilling capacity	<p>In the Netherlands, the <i>Code of Practice Geothermal Well Design</i> is used to define some minimum requirements to reduce well integrity related risks. Similar practices could be adapted by the other EU member countries.</p> <p>Country specific rig safety cases and training of crews are examples of hurdles that can be solved with EU standards to create a larger supply of services &amp; equipment.</p>
EU support schemes, flanking measures and frameworks on heat transition	A common CO2 prevention incentive plan and flanking measures will prevent EU internal competition and provides long term guidance for project developers	<p>The right scheme for the right market maturity</p> <p>High level and long term planning is needed to assist in planning on lower levels</p>
EU financial programs & best practices for project financing	Access to renewable funding programs on risk mitigation or guidelines for heat purchase agreements	Access to programs and provision of guideline will help project developers to carry out project development decisions.
Support R&D of novel concepts / key technologies and facilitation of trials	<p>New developments such as co-generation, triple generation (producing electricity, heat and i.e. Lithium) can improve business cases in the (near) future.</p> <p>Alternative systems, such as closed-loop systems, together with novel drilling and completion technology may be needed to expand the use of geothermal energy once the most obvious targets have been developed.</p>	Development and implementation of new concepts and technology i.e. for drilling and production (subsurface & surface) enhancement, takes long time and is risky - that needs mitigation & acceleration.

Overhauling and simplifying mining rules Digitalization / digital transformation	Removal of bureaucratic hurdles, promotion of efficiency via digitalization, and establishment of a more conducive environment for geothermal growth and sustainability	Streamlined and harmonized permitting process - digital and user-friendly. Enhanced coordination and simplification of approval processes (consolidation under one authority). Development of a comprehensive legal framework for approval procedures, digitizing these processes for efficiency, and establishing a specific Geothermal Exploration Law. Implement fixed terms for procedures and introduction of "fast permitting" areas, (projects with minimal impact and risk can proceed more rapidly).
Creation of favourable market and economic conditions Risk-mitigating mechanisms for financial stable projects to attract also i.e. low risk affine investors (alignment with the "green deal" ethos)	New exploration & production insurance scheme Insurance products of realisation risks incl. Lost-In-Hole of drilling equipment and CAR. Establishment of heat infrastructure funding schemes, market incentives, and heat purchase agreements, integrating a CO2 prevention incentive system to support industry partners.	Geological risk insurance to support project developers especially in lesser known areas. In NL, RNES can be expanded or offered at reduced cost. An advantage over SCAN would be that wells are drilled on the location of the project in development and developers don't wait for the results, i.e. in case of no failure project realisation is half way. Lost-In-Hole of drilling equipment is difficult to insure at the moment and may lead to suboptimal engineering decisions. Similar to general project execution risks. A portfolio approach (i.e. across various countries) is needed aiming to reduce cost. Attractive financial instruments/models/tools to attract private investors, including pension funds and insurances, aligning with the "green deal" ethos, i.e. like the Canadian growth fund.
Accessible & valuable project data is base for good projects	A central knowledge hub or database accessible to everybody via the internet with good (subsurface) data is crucial to successful develop projects.	Opposed to most other countries, in the Netherlands the access to subsurface data well organised with databases as i.e. NLOG, ThermoGIS. The SCAN project has been established to further increase the data availability and accessibility - further white spots need to be "scanned" to improve the data amount and enable municipalities/private investors/industry to consider geothermal energy as valuable source.
(Public) acceptance is a pre-requisite and starts with awareness Information transparency Commitment to social acceptance - prioritization of sustainability and innovation	Visibility is needed to create awareness and media exposure can be created with visits from top politicians showing leadership Developing large scale projects in a targeted (high impact) areas will generate fly-wheel effects Well-informed municipalities can lead the heat transition as good examples	(Non-pricing) benefits of geothermal energy need to be made clear to the public consistently: local, accessible, competitive, quality of life, stable price, available Informing public and local decision makers using training/information sessions for municipalities and focussed local/regional communication campaigns on geothermal energy External
National roadmap, (local) heat transition plans	A national roadmap with regular progress monitoring sessions amongst key stakeholders will identify hurdles efficiently (Mandatory) local heat planning will force municipalities to consider all solutions including geothermal energy Collaborative approach among involved governmental, public and financial institutions such as EZK, Invest-NL, RVO, EBN and TNO	Long term and maintained roadmaps provide stability for all stakeholders including drilling contractors Roles of public organisations as EZK, Invest-NL, RVO, EBN and TNO to be clarified Implementation should be regularly monitored and process/progress during regular meetings discussed/updated (participants: strategic key persons from involved parties).
(Local) Public-Private Partnerships (PPP)	Share the financial burden and access public funding Collaboration to use the best of both worlds Early involvement of municipalities Local expertise and capacities	PUP, PPP, public, private projects all exist but PPP benefits from having specific local knowledge and commitment combined with commercial objectives and knowledge. Private & public parties have access to different funding and benefits External specialist companies may be used to assist in structuring of governance and finance
Heat nets	District heating & the establishment of heat nets is a key pre-requisite to develop geothermal energy and other sustainable heat sources in an effective manner	Separate funding for drilling and grid net financing Alignment of heat net and heat source construction
Cooperation and exchange of best practices among cities and politicians	NL is leading in fields of underground thermal storage, over 15 years of drilling & production experience in depth between 2500 & 3500m, guarantee schemes	International exchange will help to learn from each other and may create fruitful discussion basis for attractive & successful project development



**11.2 Appendix 2: Answering questions**

**11.2.1 What guarantees and certainties are needed to attract investors for large-scale geothermal projects in the Netherlands?**

To attract investors for large-scale geothermal projects in the Netherlands, several guarantees and certainties are essential. Investors typically seek a combination of financial, regulatory, and operational assurances to mitigate risks and ensure a stable investment environment. Here are key elements that can attract investors:

**11.2.1.1 Reliable geological data and exploration**

Investors need access to comprehensive geological data and a proven track record of successful deep geothermal exploration in the Netherlands to assess the potential of geothermal resources in specific locations.

Information should include detailed geological maps, seismic data, and borehole logs to inform the feasibility of project development.

A large amount of data is already provided through Nlog.nl and more recent data can be acquired via EBN.

**11.2.1.2 Geological Risk Mitigation**

**Table 11: Conclusions – Geological risk mitigation**

<b>Geological Risk Mitigation:</b>	
-	Geological Studies: Conduct geological assessments and provide detailed information on subsurface conditions to mitigate geological exploration risks.
-	Pre-Exploration Funding: Offer funding or incentives specifically for the pre-exploration phase, demonstrating a commitment to reducing early-stage risks e.g. seismic data acquisition.
-	Result: Clear evidence of the stability and sustainability of the geothermal reservoir.

**11.2.1.3 Robust regulatory framework and consistent permitting processes**

A clear and stable regulatory framework is crucial for attracting investors, ensuring predictability and minimizing regulatory hurdles. This framework should include specific regulations for deep geothermal projects, outlining permitting procedures, environmental impact assessments, and safety requirements. Consistent and timely permitting processes are essential to maintain investor confidence and avoid delays that could impact project profitability.

**Table 12: Conclusions - regulatory framework & permitting processes.**

<b>Government Support and Commitment / grants and subsidies:</b>	
-	Availability and accessibility of government grants or subsidies for geothermal projects.
-	Evidence of successful participation in government incentive programs.
-	Government Participation: Consider government participation in early-stage projects to signal commitment and reduce perceived risks.
-	Policy Consistency: Ensure consistency in policies related to energy, environment, and sustainability to build investor confidence.
-	„Pakt für Planungs-, Genehmigungs- und Umsetzungsbeschleunigung zwischen Bund und Ländern (coalition agreement)“
<b>Policy and Regulatory Stability:</b>	
-	Long-Term Commitment: Clear and consistent government policies that demonstrate a long-term commitment to geothermal energy development.
-	Future proof heat net regulations

- Regulatory Clarity: Transparent and predictable regulatory frameworks that facilitate project development and operation.
<b>Permitting Process Streamlining:</b>
- Efficient Permitting: Streamline and shorten the permitting process to reduce delays and uncertainties, creating a more attractive environment for investors.

#### 11.2.1.4 Long-term feed-in tariffs and price support

Stable and attractive feed-in tariffs or other price support mechanisms are essential for project economics and investor confidence. These mechanisms should guarantee a minimum price for the generated geothermal energy over a long-term period (30 years), providing investors with a reliable revenue stream to justify their investment.

**Table 13: Conclusions - Long-term feed-in tariffs and price support**

<b>Financial Incentives and Support:</b>
- Tariff Guarantees: Provide guarantees or stable tariff structures for geothermal energy, ensuring a predictable revenue stream for investors.
- Financial Support: Offer financial incentives, subsidies, or grants to reduce the financial risks associated with geothermal projects.
<b>Financial Guarantees:</b>
- Demonstrating the financial viability of the project through sound financial modeling.
- Clear plans for debt financing and equity participation, including details on expected returns.
<b>Contractual Agreements:</b>
- Power Purchase Agreements (PPAs): Secure long-term PPAs with off-takers, providing revenue certainty for investors.
- Clear Legal Agreements: Ensure clear and comprehensive legal agreements between project developers, investors, and off-takers to define roles and responsibilities.
<b>Market Demand and Off-Take Agreements:</b>
- Market Assessment: Provide evidence of market demand for geothermal energy and potential off-take agreements.
- Pro-active develop Heat nets
- Diverse Revenue Streams: Explore opportunities for diversifying revenue streams, such as direct use applications or supplying multiple off-takers.
<b>Exit Strategies:</b>
- Clear Exit Routes: Outline clear exit strategies for investors, providing assurance that there are viable options for divesting or transferring their interests.

#### 11.2.1.5 Risk-sharing mechanisms and insurance

To mitigate the financial risks associated with deep geothermal projects, such as failed wells or unexpected geological challenges, risk-sharing mechanisms are essential. These mechanisms can include insurance schemes, government guarantees, or equity participation from government or private investors to share the financial burden in the event of unforeseen issues.

**Table 14: Conclusion – Risk & insurance**

<b>Risk Mitigation Mechanisms:</b>
- Insurance Options: Explore insurance mechanisms to cover potential risks related to exploration, drilling, and project operation. Expand RNES possibilities
- Government Backing: Consider government-backed guarantees to mitigate certain project risks and attract private investment.
<b>Environmental and Social Impact Mitigation:</b>
- Environmental Standards: Adhere to and exceed environmental standards, addressing concerns related to the impact of geothermal projects.
- Social Safeguards: Implement social safeguards to address community concerns and ensure responsible project development.

<b>Environmental, Social, and Governance (ESG) Considerations:</b>
- Clear commitment to and compliance with ESG standards.
- Implementation of sustainable practices and minimizing the environmental impact.

### 11.2.1.6 Public support and community engagement

Public awareness and support are crucial for gaining regulatory approvals and minimizing community opposition. Project developers should engage with local communities early on, providing transparent information about the project, its potential benefits, and any potential impacts. Open communication and community engagement can foster a positive relationship with stakeholders and reduce potential opposition.

**Table 15: Conclusion - Community Engagement and Support**

<b>Community Engagement and Support:</b>
- Public Awareness: Develop public awareness campaigns to garner community support, creating a favorable environment for project development. Create a mood / scenario and public acceptance for a regional value creation and its high value.
- Community Benefits: Outline clear community benefits, such as local job creation, infrastructure improvement, or community investment, to build local support.
- Promote PUP and PPP
<b>Transparent Reporting and Communication</b>
- Commitment to transparent reporting on project progress and financial performance.
- Open communication with investors and stakeholders.

### 11.2.1.7 Technological advancements and operational expertise

Investing in research and development for deep geothermal technologies, as well as promoting operational expertise and knowledge transfer, can improve project success rates and reduce the perception of risk among investors. Technological advancements can enhance drilling efficiency, resource recovery, and overall project economics.

**Table 16: Conclusion - Technology**

<b>Technology and Operational Excellence:</b>
- Proven Technologies: Demonstrate the use of proven and reliable geothermal technologies, reducing technology-related risks.
- Operational Track Record: Highlight successful operational track records of project developers, showcasing their ability to manage and operate geothermal projects effectively.
- Partnerships with reputable technology providers and contractors.
-
<b>Grid Connection and Infrastructure:</b>
- Assurance of reliable grid connection for power distribution.
- Adequate infrastructure, including roads and utilities, to support the geothermal project.

By addressing these factors, a geothermal project in the Netherlands can provide investors with the confidence and assurances needed to support large-scale investments in sustainable energy infrastructure. Additionally, collaborating with relevant government agencies, industry experts, and local communities can enhance the overall success of geothermal projects.

## 11.2.2 How can we promote cooperation between government, industry, and financial institutions to stimulate geothermal energy on a large scale?

Promoting cooperation between government, industry, and financial institutions is crucial for stimulating large-scale geothermal energy projects in the Netherlands. Here are strategies to foster collaboration and create a supportive ecosystem:

### 11.2.2.1 Establish a Geothermal Task Force

*Create a dedicated task force involving representatives from government agencies, industry players, and financial institutions.*

*Consider the involvement of municipal representatives in those task-forces.*

*The task force can serve as a platform for regular collaboration, discussion, and joint decision-making.*

*Enhance collaboration between authorities: The government could foster collaboration between central and local authorities by establishing joint working groups, sharing data and information, and aligning policies and procedures.*

#### 1) Improve the National Geothermal Energy Roadmap

*Collaborate to develop a comprehensive roadmap outlining the country's strategic goals, priorities, and milestones for geothermal energy development. The roadmap should identify key investment opportunities, target locations, and potential funding mechanisms.*

#### 2) Establish strategic Alliances

*Similar to the concept in Germany where municipal utility companies team up with research institutions (i.e. Geothermie Allianz in NRW, Geothermie Allianz Bayern, GeoEnergie Allianz Berlin-Brandenburg GEB)*

#### 3) Create a Knowledge Hub

*Establish a knowledge hub or database that provides comprehensive information on geothermal resources, project feasibility studies, and best practices for geothermal energy development in the Netherlands.*

### 11.2.2.2 Partnerships / strategic alliances

#### 1) Private-public partnership (PPPs)

*Encourage the formation of public-private partnerships where government entities, industry stakeholders, and financial institutions collaborate on geothermal projects to accelerate project development, and optimize resource utilization.*

*Develop frameworks for sharing risks, responsibilities, and rewards among the public and private sectors.*

#### 2) Public-public partnerships (PUPs)

*Encourage the formation of public-public partnerships where municipalities enter an agreement to cooperate to i.e. set up a company to run geothermal projects, and participate with own capital as well as collaborate with financial institutions to accelerate project development, and optimize resource utilization.*

*Develop frameworks for sharing risks, responsibilities, and rewards among the public sector.*

*Reference:*



- [Interkommunale Fördergesellschaft GEMO gegründet | Informationsportal Tiefe Geothermie](#)

### 11.2.2.3 Joint Research and Development Programs

Facilitate collaborative research and development initiatives to advance geothermal technologies and reduce exploration and drilling risks.

- Example: KI research project “En-eff\_Netzregelung” – cooperation between SWM, AGFW, IAT of University in Bremen, HafenCity Universität (HCU) Hamburg to develop energy efficient and longterm operation of heat and cold network ([SWM gründen KI-Forschungsprojekt „En-eff Netzregelung“ | Informationsportal Tiefe Geothermie](#))

Dedicate funding to R&D initiatives that focus on improving geothermal drilling technologies, enhancing resource recovery efficiency, and developing innovative energy conversion systems.

### 1) National Geothermal Energy Platform

Create a centralized platform that brings together representatives from government agencies, industry players, and financial institutions to facilitate knowledge exchange, foster collaboration, and identify areas for joint investment and support.

Improve information content in/of NLOG.

### 11.2.2.4 Governmental-Backed Financing Programs

Introduce financing programs with government backing to reduce financial risks for investors and financial institutions.

Provide loan guarantees, interest rate subsidies, or other financial instruments to attract private investment.

### 11.2.2.5 Stable and Supportive Policy Environment

Ensure a stable and supportive policy environment that aligns with the long-term goals of the geothermal sector.

Regularly engage with industry and financial stakeholders to gather input for policy development.

### 11.2.2.6 Financial Incentives and Subsidies

Offer financial incentives and subsidies to make geothermal projects more financially attractive.

Work with financial institutions to design incentive structures that align with project financing requirements.

Establish risk-sharing mechanisms, such as insurance schemes, government guarantees, or equity participation, to mitigate financial risks associated with deep geothermal projects and encourage investment.

### 11.2.2.7 Capacity Building and Training

Invest in capacity-building initiatives to enhance the skills of professionals in government, industry, and financial institutions.

Invest in training and skill development programs to equip the workforce with the necessary competencies for designing, constructing, and operating geothermal energy projects.

Foster collaboration through joint training sessions and workshops.

#### 11.2.2.8 Clear and Streamlined Permitting Processes

*Collaborate to streamline and harmonize permitting/regulatory processes and reduce administrative burdens for geothermal energy projects, ensuring predictability and reducing the time required for approvals and permitting.*

*The government could simplify and expedite the permitting process by establishing clear and consistent guidelines, creating one-stop shops for permit applications, and using digital platforms for submissions and tracking.*

*Establish clear guidelines and timeframes for permitting to provide certainty for investors and industry players.*

#### 11.2.2.9 Regular Stakeholder Forums

*Organize regular forums or conferences that bring together government officials, industry leaders, financial institutions others involved (i.e. municipalities, industries etc.).*

*Create opportunities for networking, information exchange, and collaborative discussions on challenges and opportunities.*

#### 11.2.2.10 Market Studies and Risk Assessments

*Conduct market studies and risk assessments collaboratively to identify potential areas for geothermal development.*

*Share findings with financial institutions to help them assess the feasibility and risks of supporting geothermal projects.*

#### 11.2.2.11 Community Engagement Strategies

*Develop joint strategies for community engagement to address concerns, build support, and ensure successful project development.*

*Involve financial institutions in community outreach efforts to enhance their understanding of local dynamics.*

#### 11.2.2.12 Joint Marketing and Promotion

*Encourage partnerships with international organizations and institutions to share expertise, access advanced technologies, and leverage global best practices in geothermal energy development.*

*Collaborate on marketing and promotional activities to raise awareness about the benefits of geothermal energy.*

*Highlight investment opportunities to attract financial institutions and promote the sector as an attractive investment.*

*Raise public awareness about the benefits of geothermal energy, address misconceptions, and ensure communities are informed about potential projects in their vicinity. This will foster public support and reduce opposition.*

### 11.2.3 What impact do different scales (local, regional, national) have on the financing and cost reduction of geothermal projects, and how should strategies be adapted accordingly?

#### 11.2.3.1 Local Scale

The local scale of geothermal projects in the Netherlands has a significant impact on their financing and cost reduction potential. This is due to several factors, including:

##### **The high upfront costs of geothermal projects:**

- *Geothermal projects require extensive drilling and infrastructure, which can be very expensive especially if a heat net is required. This high initial cost makes it difficult for geothermal projects to attract traditional financing from investors who are looking for high returns on their investments.*

##### **The long payback periods for geothermal projects:**

- *Geothermal projects can take many years to start producing heat, and their production costs are typically lower than those of fossil fuel-fired power plants. However, the long payback period makes it difficult for geothermal projects to compete with other forms of energy generation.*

##### **The limited availability of geothermal resources:**

- *High-quality geothermal resources are not evenly distributed throughout the Netherlands and may be located in more remote areas or under protected lands. This can make it difficult and expensive to develop geothermal projects.*

##### **The regulatory uncertainty surrounding geothermal development:**

- *The regulatory environment for geothermal development and heat nets in the Netherlands is still evolving, and there is some uncertainty about the rules and permitting processes that will apply to new projects. This uncertainty can make it difficult for investors to assess the risks and rewards of geothermal projects.*

To overcome these challenges and make geothermal projects more viable in the Netherlands, it is important to develop strategies that take advantage of the local scale. Some of these strategies include:

##### **Focusing on smaller, more modular projects:**

- *Smaller, more modular projects, i.e. start with a single doublet but plan for multiple doublet system, can be more affordable to develop and can be deployed at lower risk more quickly than large-scale projects. This can make them more attractive to investors and can help to shorten the payback period for geothermal projects.*

##### **Financing Options:**

- *Explore local financing models, including community-based funding or partnerships with local investors and PUP or PPP structures.*

##### **Developing community-owned geothermal projects / community-based energy cooperatives or joint ventures with local businesses:**

- *Those type of geothermal projects can raise capital and/or long term heat contracts from local residents and businesses, and they can also provide economic benefits to the community in the form of jobs and tax revenue. This can help to build public support for geothermal development and can reduce the risk of regulatory opposition.*

##### **Partnering with local government:**

- Local governments can play a key role in supporting geothermal development by providing funding, streamlining permitting processes, and educating the public about the benefits of geothermal energy. This can help to create a more favorable environment for geothermal projects.

**Permitting and Approvals:**

- Local authorities play a crucial role. Streamlining local permitting processes can reduce delays and associated costs.

**Investing in research and development:**

- Research and development is essential for developing new technologies that can reduce the cost and improve the efficiency of geothermal projects. This includes technologies for drilling, extracting geothermal fluids, and storing geothermal energy.

### 11.2.3.2 Regional Scale

The regional scale of geothermal projects plays a significant role in their financing and cost reduction prospects. Larger-scale projects generally attract more investors and lenders, as they present a more attractive risk-return profile. Additionally, larger projects can benefit from economies of scale in procurement, construction, and operation, leading to lower overall costs.

**Financing Opportunities:**

- Large-scale geothermal projects are more likely to secure financing from institutional investors like pension funds and insurance companies. These investors are typically seeking long-term investments with predictable returns, and geothermal energy offers a stable and reliable source of renewable electricity. Additionally, larger projects may attract government grants or loans, further reducing their financial burden.

**Economies of Scale:**

- As geothermal projects increase in size, they can leverage economies of scale in various aspects of their development and operation. Large drilling rigs can drill multiple wells simultaneously, reducing the time and cost of accessing geothermal resources. Larger power plants can utilize more efficient heat exchangers and turbines, improving energy conversion efficiency and reducing operating costs. Additionally, larger projects can benefit from economies of scale in material procurement and logistics, further lowering expenses.
- To effectively leverage the benefits of regional scale and reduce the costs of geothermal projects, strategic adaptations are necessary. These adaptations can be categorized into three main areas:

**Project Planning and Design**

- *Optimize Well Locations and Spacing:* Carefully plan well locations to maximize resource extraction while minimizing environmental impacts. Optimize well spacing to ensure efficient heat transfer between the reservoir and the wellbore.
- *Leverage Modular Power Plants:* Consider modular power plant designs, which allow for easier transportation, assembly, and scalability. Modular plants can be expanded or downsized as project requirements evolve.
- *Joint investment and coordination in mapping of the subsurface*

**Procurement and Supply Chain Management**

- *Negotiate Group Purchase Contracts: Collaborate with other geothermal projects to negotiate bulk purchase agreements for materials and equipment, securing better pricing and reducing supply chain costs.*
- *Establish Local Supply Chains: Encourage local manufacturing and supply of materials and components, reducing transportation costs and promoting economic development in the region.*

#### **Project Management and Operations**

- *Implement Innovative Drilling and Construction Techniques: Utilize advanced drilling technologies and construction methods to optimize well completion and minimize downtime.*
- *Develop Standardized Operating Procedures: Establish standardized operating procedures for maintenance, monitoring, and troubleshooting, ensuring efficient operations and maximizing resource recovery.*

#### **Collaboration**

- *Collaborate with neighboring communities or stakeholders to share subsurface data, resources and costs.*

#### **Policy Alignment:**

- *Align regional policies to support geothermal projects, creating a favorable environment for financing and development.*

#### **Regulatory framework:**

- *A supportive regulatory framework at the regional level can provide clarity and certainty for developers, encouraging investment and facilitating the development of geothermal projects.*

#### **Interconnected networks:**

- *Development of interconnected geothermal networks can reduce the cost of infrastructure and improve the overall efficiency of the regional energy system. Developers should collaborate with regional authorities to plan and develop these networks.*

#### **Public awareness campaigns:**

- *Raising public awareness about the benefits of geothermal energy at the regional level can create a more favorable environment for project development. Developers can partner with regional authorities and non-governmental organizations to conduct public outreach campaigns.*

#### **11.2.3.3 National Scale**

National scale plays a significant role in influencing the financing and cost reduction of geothermal projects. A broader national approach can bring about several advantages, including:

#### **Shared Risk and Funding:**

- *By pooling resources and expertise across multiple projects, a national strategy can minimize the financial risk for individual developers. This can attract more investors and lenders to geothermal projects, leading to more efficient allocation of resources.*

#### **Standardization and Economies of Scale:**



- A centralized approach can facilitate the standardization of geothermal technology and processes, leading to reduced costs and improved efficiency. This can be achieved through coordinated research and development, shared best practices, and harmonized regulations.

**Streamlined Regulatory Environment:**

- A national strategy can simplify and streamline the regulatory approval process for geothermal projects. This can reduce the time and cost associated with project development and make geothermal energy more attractive to investors.

**Knowledge Sharing and Collaboration:**

- A collaborative national effort can foster knowledge sharing and collaboration among experts, researchers, developers, and policymakers. This can accelerate innovation, optimize project design, and reduce overall costs.

To effectively adapt strategies for financing and cost reduction in geothermal projects, the following measures should be considered to be implemented:

**National energy policy:**

- A much more supportive national energy policy that prioritizes renewable energy sources, such as geothermal energy, can provide a strong foundation for geothermal development. This includes policies that promote investment, provide incentives, and streamline permitting processes.

**Establishment of a National Geothermal Platform:**

- Create a central platform to bring together stakeholders from the government, industry, research institutions, and communities. This platform can facilitate coordination, information sharing, and decision-making related to geothermal energy development.

**Implement Risk-Sharing Mechanisms:**

- Explore risk-sharing mechanisms, such as public-private partnerships or mutual funds, to pool resources and mitigate financial risks associated with geothermal projects. This can make geothermal investments more attractive to private investors.

**Promote Technology Standardization:**

- Encourage the development and adoption of standardized geothermal technologies and processes. This can reduce the cost of equipment, simplify maintenance, and facilitate the exchange of expertise among developers.

**Policy Framework:**

- National policies can significantly impact geothermal project viability. Advocate for supportive national policies and incentives.

**Foster Knowledge and Technology Transfer:**

- Establish mechanisms for knowledge sharing and technology transfer between research institutions, industry players, and policymakers. This can accelerate innovation and optimize project design, leading to cost reductions.

**Research and Development:**

- National support for research and development can contribute to technological advancements, driving cost reductions.

**Grid Integration:**

- National energy planning and grid integration strategies can enhance the overall effectiveness of geothermal projects.

#### **Data sharing and standardization:**

- Establishing standardized data formats and protocols at the national level can facilitate the sharing of valuable geological and technical data, which can reduce the risks and costs of geothermal projects.
- Support municipalities with subsurface data

#### **11.2.3.4 Summary - Adaptation Strategies**

No.	Strategies
1	<p><b>Tailored Financing Models:</b></p> <p><i>Adapt financing models to suit the scale. Local projects may benefit from community-driven financing, while larger projects could explore institutional investments.</i></p>
2	<p><b>Policy Advocacy:</b></p> <p><i>Advocate for geothermal-friendly policies at all levels. Tailor advocacy strategies to address local, regional, and national policy concerns.</i></p>
3	<p><b>Technology Standardization:</b></p> <p><i>Standardize technologies and practices where possible. This can lead to cost reductions and streamlined project development.</i></p>
4	<p><b>Risk Mitigation:</b></p> <p><i>Implement risk mitigation strategies relevant to each scale. This may involve insurance mechanisms for local projects and collaborative risk-sharing for regional or national initiatives.</i></p>
5	<p><b>Capacity Building:</b></p> <p><i>Invest in local and regional capacity building to ensure that stakeholders have the necessary expertise to plan, implement, and maintain geothermal projects.</i></p>
6	<p><b>Knowledge Sharing:</b></p> <p><i>Facilitate knowledge sharing between different scales to leverage successful strategies and avoid pitfalls.</i></p>
7	<p><b>Locally tailored solutions:</b></p> <p><i>Developers should tailor their strategies to the specific needs and circumstances of the local community, considering factors such as cultural sensitivities, environmental concerns, and economic priorities.</i></p>
8	<p><b>Collaborative partnerships:</b></p> <p><i>Collaborating with local authorities, regional stakeholders, and national policymakers can help developers navigate the complex regulatory landscape and leverage available resources effectively.</i></p>

9

**Adaptive planning:**

*Geothermal projects are often long-term investments, and developers need to be prepared to adapt their strategies as market conditions, technologies, and regulatory frameworks evolve.*

### 11.2.4 How can licence applications to central and local authorities be accelerated?

Accelerating license applications to central and local authorities in the Netherlands involves streamlining processes, improving communication, and creating a more efficient regulatory framework. Here are strategies to expedite the license application process:

#### 11.2.4.1 Centralized Measures

Table 17: Centralized measures – licence applications

<p><b>1. Single-Window Clearance / One-stop shops:</b></p> <p><i>Establish a single-window clearance system for geothermal license applications, where applicants can submit all necessary documents and receive approvals from various authorities through a centralized platform. Although done in NL via <a href="https://overheid.nl">Home - Omgevingsloket (overheid.nl)</a>, its functioning needs to be reviewed.</i></p>
<p><b>2. Pre-Application Consultations:</b></p> <p><i>Offer pre-application consultations to potential applicants with relevant authorities, providing guidance on the application process, requirements, and expectations. This can help avoid common issues and streamline the formal application.</i></p>
<p><b>3. Fast-Track Options:</b></p> <p><i>Introduce fast-track options for projects that meet specific criteria, such as proven technology, low environmental impact, or alignment with strategic goals. Fast-tracking can expedite the approval process for qualifying projects.</i></p>
<p><b>4. Integrated Environmental Impact Assessment (EIA):</b></p> <p><i>Integrate the environmental impact assessment (EIA) process into the overall license application process. This avoids duplication of efforts and accelerates the overall timeline.</i></p>

#### 11.2.4.2 Local Authority Collaboration

Table 18: Local authority collaboration – licence applications

<p><b>1. Local Authority Training:</b></p> <p><i>Provide training sessions for local authorities to enhance their understanding of geothermal projects, associated benefits, and the regulatory framework. Well-informed authorities are more likely to process applications efficiently.</i></p>
<p><b>2. Early Engagement with Local Communities:</b></p> <p><i>Encourage early engagement with local communities to address concerns and gather input. Proactively involving communities can prevent delays due to objections during the application review.</i></p>
<p><b>3. Local Pre-Application Meetings:</b></p> <p><i>Facilitate pre-application meetings at the local level to discuss projects with relevant stakeholders, including local authorities, communities, and environmental groups. This can identify potential issues early on and streamline the application process.</i></p>

**4. Clear Communication Channels:**

*Establish clear communication channels between project developers and local authorities. Regular updates, progress reports, and feedback mechanisms can help maintain transparency and resolve issues promptly.*

**5. Local Authority Coordination:**

*Coordinate efforts between different local authorities involved in the approval process. This includes planning, environmental, and building authorities. A coordinated approach reduces bureaucratic hurdles.*

**6. Joint working groups:**

*Establishing joint working groups between central and local authorities can foster cooperation and ensure alignment on permitting requirements.*

**7. Sharing data and information:**

*Sharing relevant data and information between authorities can help to streamline the permitting process and reduce the risk of duplication of effort.*

**8. Aligning policies and procedures:**

*Aligning policies and procedures across different levels of government can reduce confusion and facilitate a more consistent approach to permitting.*

**11.2.4.3 Overall Strategies****Table 19: Overall Strategies - – licence applications****1. Risk-Based Approaches:**

*Implement risk-based approaches to regulatory assessments. Allocate resources based on project risk profiles, allowing authorities to focus on areas with higher potential impact.*

**2. Performance Metrics and Monitoring:**

*Define performance metrics for the application process, including average processing times and approval rates. Regularly monitor and evaluate these metrics to identify areas for improvement.*

**3. Public-Private Collaboration:**

*Foster collaboration between public and private entities to address challenges collectively. Public-private partnerships can lead to shared resources, expertise, and a more efficient application process.*

**4. Continuous Process Improvement:**

*Establish mechanisms for continuous process improvement. Regularly review and update processes based on lessons learned, technological advancements, and changing regulatory requirements.*



**5. Legislative and Policy Reforms:**

*Consider legislative and policy reforms to simplify and expedite the geothermal licensing process.*

- *Reference: Geothermal Development Act (similar to the SWM approach – baseline: “Wind-an-Land Gesetz”)*

**6. Utilize technology to accelerate permitting process:**

*Implementation of digital workflows: Utilizing digital workflows for submitting, reviewing, and approving permits can reduce the need for manual processing and expedite approvals.*

*Artificial intelligence (AI): Employing AI tools to analyze permit applications and identify potential issues can streamline the review process and reduce the risk of delays.*

*Provision of real-time tracking: Providing real-time tracking of permit applications can allow developers to monitor the progress of their applications and identify any potential roadblocks promptly.*

### 11.2.5 How can the knowledge of geothermal energy among central and local authorities be increased?

Increasing knowledge of geothermal energy among central and local authorities in the Netherlands involves targeted educational initiatives, training programs, and collaborative efforts. Here are strategies to enhance their understanding:

#### 11.2.5.1 Programs

No.	Type of programs
1	<p>Organize regular training, seminars and workshops:</p> <p><i>Conduct specialized training sessions and workshops specifically for central and local government officials to provide them with in-depth knowledge of geothermal energy, its technical aspects, economic viability, and environmental impacts. These sessions should cover the latest advancements in geothermal technology, project development processes, and regulatory frameworks.</i></p>
2	<p>Online Training Modules:</p> <p><i>Develop online training modules that provide convenient access to educational content. These modules can cover geothermal technology, project financing, environmental considerations, and regulatory frameworks.</i></p>
3	<p>Establish a dedicated geothermal energy task force:</p> <p><i>Form a dedicated task force or working group within central and local government agencies that focuses on geothermal energy development. This task force should bring together experts from various disciplines, including geology, engineering, energy policy, and environmental assessment, to provide expert advice and support to decision-makers.</i></p>
4	<p>Promote case studies and success stories:</p> <p><i>Share real-world examples of successful geothermal energy projects in the Netherlands and other countries. This can be done through presentations, conferences, and publications to demonstrate the feasibility and benefits of geothermal energy.</i></p>
5	<p>Foster collaboration with research institutions and industry experts:</p> <p><i>Collaborate with universities, research institutes, and geothermal energy companies to gather expertise and knowledge on the latest developments in geothermal technology. Regular knowledge exchange sessions and joint research projects can help inform policy decisions and project implementation. Develop geothermal energy courses and training programs tailored for central and local authorities.</i></p> <p><i>Partnerships with Industry Associations: Partner with industry associations to provide training sessions, share industry insights, and engage in joint initiatives aimed at increasing awareness and understanding.</i></p>
6	<p>Develop educational materials and resources:</p> <p><i>Create accessible educational materials and resources, such as infographics, videos, and online courses, to raise awareness about geothermal energy among government</i></p>

	<i>officials, schools and the general public. This will promote understanding and acceptance of this renewable energy source.</i>
<b>7</b>	<p>Establish a knowledge hub or online platform:</p> <p><i>Create a central online platform or knowledge hub dedicated to geothermal energy in the Netherlands. This platform should provide comprehensive information on resource potential, project development processes, best practices, and relevant legislation, hence expand <a href="https://www.allesoveraardwarmte.nl/">https://www.allesoveraardwarmte.nl/</a></i></p>
<b>8</b>	<p>Promote international partnerships and knowledge sharing:</p> <p><i>Engage in international collaborations and partnerships with geothermal energy experts, organizations, and governments from other countries. This will facilitate knowledge exchange, access to advanced technologies, and the adoption of best practices.</i></p>
<b>9</b>	<p>Field Visits:</p> <p><i>Arrange field visits to existing geothermal projects, including drilling sites, power plants, and district heating installations. Hands-on experiences can significantly enhance comprehension.</i></p>

#### 11.2.5.2 Collaborative Initiatives

<b>No.</b>	<b>Type of collaboration</b>
<b>1</b>	<p>Public-Private Partnerships:</p> <p><i>Foster public-private partnerships to facilitate knowledge exchange between government agencies and geothermal industry experts. Collaboration can lead to joint training programs and research initiatives.</i></p>
<b>2</b>	<p>Government-Industry Roundtables:</p> <p><i>establish regular roundtable discussions between government officials and industry representatives. These forums provide a platform for sharing insights, addressing concerns, and promoting collaboration.</i></p>
<b>3</b>	<p>Advisory Committees:</p> <p><i>Form advisory committees with geothermal experts who can provide guidance to central and local authorities. These committees can offer advice on policy development, project assessments, and regulatory frameworks.</i></p>
<b>4</b>	<p>Awareness Campaigns:</p> <p><i>Geothermal Energy Awareness Campaigns: Launch awareness campaigns focused on geothermal energy. These campaigns can include informational materials, public events, and targeted communication to central and local authorities.</i></p> <p><i>Media Engagement: Engage with mainstream and industry-specific media to raise awareness about the benefits and potential of geothermal energy. Interviews, articles, and documentaries can contribute to knowledge dissemination.</i></p>

	<i>Community Outreach: Include geothermal education in community outreach programs. Local authorities are more likely to support geothermal projects when they understand the benefits for their communities.</i>
5	Conferences / Städte-Workshops <i>Example: <a href="http://norddeutsche-geothermietagung.de">Norddeutsche Geothermietagung   Vorträge (norddeutsche-geothermietagung.de)</a></i>

### 11.2.5.3 Educational Materials

No.	Type of educational material
1	Geothermal Handbooks and Guides: <i>Develop comprehensive handbooks and guides that central and local authorities can reference. These materials should cover the fundamentals of geothermal energy, project development processes, and regulatory requirements.</i>
2	Online Resource Portals <i>Create online resource portals that centralize information on geothermal energy. These portals can serve as repositories for reports, guidelines, and relevant studies.</i>
3	Webinars and Podcasts: <i>Conduct webinars and podcasts featuring experts in the field of geothermal energy. These formats allow authorities to learn from industry professionals without requiring extensive time commitments.</i>

### 11.2.6 How can geothermal investments be insured through the government?

The government can play a role in facilitating geothermal investments in the Netherlands by providing insurance or risk mitigation mechanisms. Here are several ways in which the government can help insure geothermal investments:

#### 11.2.6.1 Government-Backed Loan Guarantees

*The government can offer loan guarantees to geothermal projects, assuring financial institutions that a portion of the loan will be repaid in the event of default. This reduces the financial risk for investors and encourages lending.*

#### 11.2.6.2 Expanding the scope of existing insurance program

*The Netherlands Enterprise Agency (RVO), the Netherlands Centraal Beheer (NCW), and the Netherlands Investment Guarantee Agency (IFG) could expand the scope of their existing insurance programs to cover more types of geothermal projects and risks.*

#### 11.2.6.3 Political Risk Insurance

*Provide political risk insurance to protect investors against risks arising from changes in government policies, regulations, or political instability that may affect the profitability of geothermal projects.*

#### 11.2.6.4 Environmental Liability Insurance

*Offer environmental liability insurance to cover potential costs associated with environmental damage caused by geothermal projects. This can include coverage for drilling accidents, fluid leakage, or other environmental impacts.*

#### 11.2.6.5 Revenue Guarantees

*Introduce revenue guarantees to investors by ensuring a stable and predictable income stream. This can be achieved through power purchase agreements (PPAs) with fixed tariff rates or minimum revenue commitments.*

#### 11.2.6.6 Exploration Risk Mitigation

- Establish a fund or insurance mechanism to mitigate the exploration risk associated with geothermal projects. This could cover costs related to unsuccessful drilling or exploration efforts.
- A pragmatic solution can be to expand RNES capabilities and lower the RNES fee especially for white post areas

#### 11.2.6.7 Infrastructure Investment Guarantees

- Provide guarantees for infrastructure investments, especially in cases where geothermal projects involve the development of new infrastructure or the expansion of existing facilities.

#### 11.2.6.8 Collaborative Risk-Sharing Mechanisms

*Explore collaborative risk-sharing mechanisms involving the government, financial institutions, and private investors. These mechanisms could distribute risks and responsibilities, making investments more attractive.*

*Co-insurance or risk-sharing programs: The government could partner with private insurance companies to offer co-insurance or risk-sharing programs. This would allow the government to share the risk of insuring geothermal projects, making it more affordable for developers.*



### 11.2.6.9 Project-Specific Insurance Products

*Work with insurance providers to develop project-specific insurance products tailored to the needs of geothermal investments. These could cover specific risks such as equipment failure, resource uncertainty, or construction delays.*

### 11.2.6.10 Insurance Premium Subsidies

*Subsidize insurance premiums for geothermal projects, reducing the financial burden on investors and making insurance more accessible.*

### 11.2.6.11 Guaranteed Off-Take Agreements

*Facilitate guaranteed off-take agreements with utilities or large consumers, ensuring that geothermal projects have a guaranteed market for their produced energy. This can enhance the bankability of projects.*

### 11.2.6.12 Public-Private (PPPs) or Public-public (PUPs) Partnerships

*Establish PPPs where the government collaborates with private investors to share risks and responsibilities. This can include joint financing, risk-sharing agreements, and co-ownership structures.*

### 11.2.6.13 Regulatory Stability Assurance

*Commit to regulatory stability over the project's lifespan, assuring investors that the regulatory environment will remain consistent. This can be achieved through long-term agreements or legislation.*

### 11.2.6.14 Investing in research and development

*The government could invest in research and development to improve the predictability and reliability of geothermal projects. This could include research on new drilling techniques, wellbore management, and power generation technologies.*

Potential benefits of insuring geothermal investments through the government in the future are:

*Increasing investor confidence: By demonstrating the government's commitment to supporting geothermal energy, insuring investments can help to increase investor confidence and attract more investment.*

*Promoting collaboration between the government and industry: By working with the private sector to develop innovative insurance products, the government can foster collaboration and share risk. This can help to reduce the overall costs of insuring geothermal investments.*

*Enhancing the reputation of geothermal energy: By insuring geothermal investments, the government can help to enhance the reputation of geothermal energy as a safe and reliable source of energy. This can make it easier to obtain financing for geothermal projects and to gain public support.*

## 11.2.7 Which restrictive general government regulations have a negative effect on the speed at which geothermal energy can be developed?

Some general government regulations in the Netherlands that have historically been considered as potential obstacles or challenges for the development of geothermal energy:

### 11.2.7.1 Complex Permitting Processes

*The permitting process for geothermal projects in the Netherlands can be lengthy and complex, involving multiple levels of government and numerous stakeholder approvals. This can delay the development of projects for several years, increasing costs and reducing their profitability.*

### 11.2.7.2 Environmental Impact Assessment (EIA)

*Stringent EIA Requirements: The environmental impact assessment process may be perceived as stringent, adding complexity to project development and potentially causing delays.*

*Environmental regulations in the Netherlands are strict, and geothermal projects must undergo rigorous environmental impact assessments (EIAs) to ensure that they do not harm the environment. This can add significant time and expense to the development process.*

### 11.2.7.3 Land Use Planning

*Land Allocation Issues: Geothermal projects may face challenges related to land use planning, as competition for land resources exists, and conflicts with existing land uses may arise.*

### 11.2.7.4 Community Engagement

*Community Resistance: Regulations around community engagement and local consultations may slow down projects if there is resistance or lack of local support for geothermal developments.*

### 11.2.7.5 Grid Connection

*Grid Connection Procedures: Connecting geothermal projects to the grid may involve regulatory hurdles and complex procedures, affecting the speed of project implementation.*

### 11.2.7.6 Subsurface Rights

*Subsurface Ownership Issues: The ownership and rights related to subsurface resources may lead to legal complexities and potentially slow down project development.*

### 11.2.7.7 Spatial Planning and Zoning Regulations:

*Zoning Restrictions: Zoning regulations may restrict the development of geothermal projects in certain areas, limiting the available sites for exploration and drilling.*

### 11.2.7.8 Government Funding Processes / Administrative Burdens for Funding / Incentives

*Accessing government funding or subsidies may involve navigating administrative processes, which can be time-consuming for project developers.*

*Limited financial incentives: The Netherlands does not provide significant financial incentives for geothermal development, such as tax breaks or subsidies. This can make it more difficult for developers to secure financing for projects.*

### 11.2.7.9 Geothermal Royalties and Fees / Royalty payments

*Regulations related to royalty payments for the use of subsurface resources may impact the financial viability of geothermal projects.*

#### 11.2.7.10 Regulatory Uncertainty

*Changing Regulatory Landscape: Frequent changes in regulations or uncertainties in the regulatory landscape can create challenges for project developers in planning and investment decisions.*

*Fragmented regulatory landscape: The regulatory landscape for geothermal energy in the Netherlands is fragmented, with different requirements and approvals required from various government agencies at the national, regional, and local levels. This can be confusing for developers and can lead to delays as they navigate the complex regulatory system.*

#### 11.2.7.11 Lack of standardized data

*The availability of geological and technical data on geothermal resources in the Netherlands is limited and often not standardized. This can make it difficult for developers to assess the viability of potential projects and can lead to delays as they seek additional information.*

#### 11.2.7.12 Lack of public support:

*There is some public opposition to geothermal projects in the Netherlands, due to concerns about environmental impacts, land use, and noise. This can lead to delays and challenges in obtaining local permits.*

It's important to note that especially regulations are subject to change, and efforts are often made to streamline processes and support the development of renewable energy projects, including geothermal. Regular dialogue between government authorities, industry stakeholders, and local communities can contribute to addressing challenges and finding solutions to promote the sustainable development of geothermal energy. Project developers and stakeholders often engage in advocacy to influence policy changes that support the growth of the geothermal sector.

### 11.2.8 How can delaying objections to geothermal energy be mitigated?

Mitigating delaying objections to geothermal energy projects in the Netherlands involves proactive community engagement, transparent communication, and addressing concerns early in the project development process. Here are proactive measures / strategies to help minimize objections and potential delays:

Items	Measures / strategies
<b>Promote use of renewable energy</b>	Geothermal energy is a renewable energy source, meaning that it does not produce greenhouse gas emissions. Emphasizing the project's contribution to renewable energy can help to gain support from environmental groups and policymakers.
	Geothermal Development Act / Acceleration act: Similar to the request of the BVG in Germany the development and use of geothermal resources should be stated within the federal law.
	Sustainability – European Energy Award (Link - <a href="https://www.bnn.de">Graben-Neudorf wird als Klimaschutzgemeinde ausgezeichnet (bnn.de)</a> )
	Compliance with ESG (environmental, social, governance) & CSRD (Corporate sustainability reporting directive) goals i.e. for municipal energy supply companies
<b>Open, Early and Transparent Communication</b>	Stakeholder Engagement: Engage with local communities, residents, and other stakeholders early in the project development phase. Provide clear information about the benefits, risks, and potential impacts of the geothermal project.
	Public Consultations: Conduct public consultations to gather input, address concerns, and build understanding. Encourage open dialogue to foster a sense of collaboration.
<b>Establishment of monitoring programs</b>	Developers should establish monitoring programs to track the project's environmental performance and to ensure that mitigation measures are effective. Monitoring data can be used to demonstrate compliance with environmental regulations and to address any concerns that arise.
<b>Community engagement</b>	Developers should actively seek input from local communities and incorporate their concerns into the project's design and mitigation plans. Community engagement can help to identify and address potential issues early on.
<b>Reputation management</b>	Developers should maintain a positive public image by engaging in responsible business practices and addressing any negative publicity promptly. A positive reputation can help to build trust and overcome objections from potential opponents.
<b>Education and Awareness</b>	Community Workshops: Organize workshops and information sessions to educate the public about geothermal energy, its safety measures, and the positive impacts on local communities.
	Educational Materials: Develop informative materials, brochures, and websites to explain geothermal technology, its environmental benefits, and safety measures.
<b>Demonstration Projects</b>	Small-Scale Demonstrations: Consider implementing small-scale geothermal demonstration projects to showcase the technology and its positive effects. These projects can serve as tangible examples for the community.
<b>Environmental Impact Assessment (EIA) Transparency:</b>	Clear EIA Communication: Clearly communicate the findings of the Environmental Impact Assessment, addressing potential environmental concerns. Emphasize the measures in place to minimize any negative impacts.

	A comprehensive EIA should be conducted to identify and assess the potential environmental impacts of the project. The EIA should be made publicly available and should be used to develop mitigation plans to minimize any adverse environmental impacts.
<b>Community Benefits Sharing</b>	Local Economic Benefits: Highlight the economic benefits for the local community, such as job creation, infrastructure development, and increased property values.
	Community Investment Opportunities: Explore options for community ownership or investment in the project, creating a sense of shared responsibility and benefits.
<b>Addressing Health and Safety Concerns</b>	Health and Safety Measures: Clearly outline the health and safety measures in place for geothermal projects, addressing concerns related to noise, emissions, or other potential risks.
	Independent Expert Reviews: Consider involving independent experts to review and validate health and safety protocols, providing additional assurance to the community.
<b>Local Employment Opportunities</b>	Job Creation Commitments: Make commitments to prioritize local employment opportunities, providing assurances that the project will contribute positively to the local economy.
<b>Land Use Planning and Zoning Collaboration</b>	Collaboration with Authorities: Work closely with local authorities to align geothermal projects with land use planning and zoning regulations. Collaborative planning can help prevent conflicts and objections.
<b>Community Advisory Boards</b>	Establish Advisory Boards: Form community advisory boards or committees that include local residents. These boards can serve as a platform for ongoing communication, addressing concerns, and fostering collaboration.
<b>Legal Clarity</b>	Clear Legal Framework: Ensure that the legal framework for geothermal projects is clear and transparent. Legal certainty can reduce the likelihood of legal challenges or objections.
<b>Mitigation Funds</b>	Community Benefit Funds: Establish community benefit funds that allocate a portion of project revenue for community development projects. This can help mitigate objections by directly contributing to the community's well-being.
<b>Mediation and Conflict Resolution</b>	Third-Party Mediation: In cases of disputes or objections, consider involving neutral third-party mediators to facilitate dialogue and find resolutions that satisfy all parties.

By implementing these strategies, project developers and authorities can create an environment of trust, collaboration, and understanding, minimizing delaying objections to geothermal energy projects.



### 11.2.9 Are the relevant subsidies still appropriate and sufficient?

The Netherlands provides various forms of financial support for geothermal projects, including grants, tax breaks, and low-interest loans. These subsidies are designed to encourage the development of geothermal energy, which is a clean and sustainable source of power.

Here is a summary of the current level of subsidies for geothermal projects in the Netherlands:

*Grants: The government provides grants to geothermal project developers for the drilling and development of geothermal wells. The amount of the grant depends on a number of factors, such as the size and depth of the well.*

*Tax breaks: The government provides tax breaks to geothermal project developers for the purchase of equipment and the installation of geothermal systems. The tax breaks can significantly reduce the cost of developing and operating geothermal projects.*

*Low-interest loans: The government provides low-interest loans to geothermal project developers for the financing of their projects. The low-interest rates can help to make geothermal projects more affordable.*

The current level of subsidies for geothermal projects in the Netherlands is relatively low compared to other countries. For example, the United States provides much higher levels of subsidies for geothermal projects.

Some experts argue that the low level of subsidies in the Netherlands is a barrier to the development of geothermal energy. They argue that the government should increase the subsidies to make geothermal projects more financially viable.

Other experts argue that the current level of subsidies is sufficient and that further increases would not be justified. They argue that the government should focus on other policies, such as streamlining the permitting process and providing information and support to geothermal project developers.

The government of the Netherlands is currently reviewing the level of subsidies for geothermal projects. A decision on whether to increase the subsidies is expected to be made in the near future.

General considerations regarding the appropriateness and sufficiency of subsidies for geothermal projects:

#### 1. Policy Alignment:

- *Further governmental subsidies should support the transition to renewable energy and contribute to sustainability targets.*

#### 2. Market Competitiveness:

- *Subsidies should help bridge the cost gap compared to other renewable sources and make geothermal projects economically viable.*

#### 3. Technology Maturity:

- *As technology advances and becomes more cost-effective, subsidy levels may need adjustment to reflect the changing economics of geothermal projects.*

#### 4. Market Demand:

- *Analyze the market demand for geothermal energy. If there is strong demand and potential for growth, subsidies may need to be sufficient to incentivize increased investment.*

#### 5. Risk Mitigation:

- *Assess whether subsidies adequately address the Risks associated with geothermal exploration and development shall be. Risk mitigation measures can include financial guarantees, insurance options, or direct financial support for exploration activities.*

#### 6. Cost-Benefit Analysis:

- *Conduct a cost-benefit analysis to determine the overall economic impact of subsidies. Consider the long-term benefits, such as reduced greenhouse gas emissions, job creation, and energy security.*

#### 7. Community and Social Benefits:

- *Examine whether subsidies adequately address community and social benefits. Geothermal projects can bring local economic development, job opportunities, and community investment, and subsidies should support these positive impacts.*

#### 8. International Comparisons:

- *Compare the subsidy levels for geothermal projects in the Netherlands with international standards. Understanding how other countries support geothermal development can provide insights into the appropriateness of subsidies.*

#### 9. Feedback from Industry Stakeholders:

- *Gather feedback from industry stakeholders, including project developers, investors, and geothermal associations. Their perspectives on the sufficiency and effectiveness of subsidies can provide valuable insights.*

### 11.3 Appendix 3: Financial models for the future

As geothermal energy becomes more widely adopted and the technology continues to develop, new financial models are being developed to better assess the risks and rewards of geothermal projects. Here are a few examples of modern financial models that are being used or could be used in the future for geothermal projects:

#### 11.3.1 Increased focus on long-term project value

As the environmental and financial benefits of geothermal energy become more widely recognized, investors are increasingly looking at long-term project value rather than short-term profitability. This will require financial models that can accurately assess the project's cash flows over its entire lifespan, including factors such as energy price projections, resource depletion rates, and operating and maintenance costs.

#### 11.3.2 Venture Capital and Private Equity

As the technology matures and proves its viability, more venture capital and private equity firms might see geothermal as an attractive investment opportunity.

#### 11.3.3 Development of risk-adjusted metrics

Geothermal projects are inherently risky due to factors such as resource variability, drilling costs, and regulatory uncertainty. Financial models will need to incorporate more sophisticated risk assessment techniques to provide investors with a clearer understanding of the project's risk profile.

#### 11.3.4 Machine Learning Models & AI-Powered Optimization Models

Machine learning models can be utilized to analyze extensive datasets, including historical drilling data, seismic data, and weather data, to identify patterns and trends that can enhance the accuracy of financial models. By analyzing these datasets, developers can gain valuable insights into geological structures, resource potential, and potential risks.

The potential of AI-powered optimization models in optimizing the design of geothermal projects is quite promising. Developers can utilize these models to optimize well placement, power plant layout, and other crucial aspects of project design, thereby improving efficiency and profitability. Additionally, AI-powered optimization models can aid in reducing operational costs and optimizing energy production.

#### 11.3.5 Integrated Financial and Technical Models

Integrated financial and technical models provide a comprehensive approach to evaluating geothermal projects. These models consider the entire value chain, from resource exploration to project development and operation, encompassing financial, technical, and operational aspects. By analyzing this holistic approach, developers can gain a deeper understanding of the project's potential return on investment (ROI) and overall feasibility.

#### 11.3.6 Scenario Analysis Models

Scenario analysis models allow developers to assess the sensitivity of geothermal projects to various economic, political, and environmental scenarios. By conducting scenario analysis, developers can identify potential risks and opportunities, enabling them to make informed decisions regarding project development.

#### 11.3.7 Adopt Real Options Models / Analysis

Real options models provide a mechanism for incorporating the flexibility of geothermal projects into financial models. Developers can utilize these models to evaluate the value of optionality, such as the ability to defer or expand the project in response to changing market conditions.

### 11.3.8 Pension Funds / life insurers

Institutional investors such as pension funds and life insurers are subject to strict rules regarding how and where they can invest. The reduction of entry barriers and attraction of same w/ i.e. exception clauses for investments in the energy transition, with state guarantees, could create a win-win situation.

### 11.3.9 Sustainable Finance Models

Sustainable finance models are becoming increasingly important in the context of geothermal projects. These models incorporate environmental, social, and governance factors into financial assessments, ensuring that projects align with sustainability goals.

#### 11.3.9.1 Integration of renewable energy credits

As more countries implement renewable energy quotas, geothermal projects can generate additional revenue by selling renewable energy credits (RECs). Financial models will need to incorporate REC prices and the potential impact of REC markets on project profitability.

#### 11.3.9.2 Green Bonds & Climate Finance

Green bonds are a type of fixed-income security that is specifically designed to finance environmentally friendly projects. Geothermal projects can potentially benefit from green bond financing, as these bonds are often issued at favorable interest rates and attract investors who are interested in supporting sustainable projects.

#### 1) Energy transition fund

BDEW, VKU, Deloitte are proposing present a hypothetical version of a future "Energy Transition Fund" (just one of many possible forms) (BDEW, VKU, Deloitte, 2023). In this energy companies would submit applications for their projects. These applications would then be reviewed and offered for purchase on a securitization or bundling platform (e.g., for securitized receivables). If sufficient investors are found, the federal government and/or state governments might contribute, for example, a third of the collected sum, which would then flow to the applicant as a silent capital contribution. Both private investors and the state would share in the profits until the fund is repaid at the end of its term.

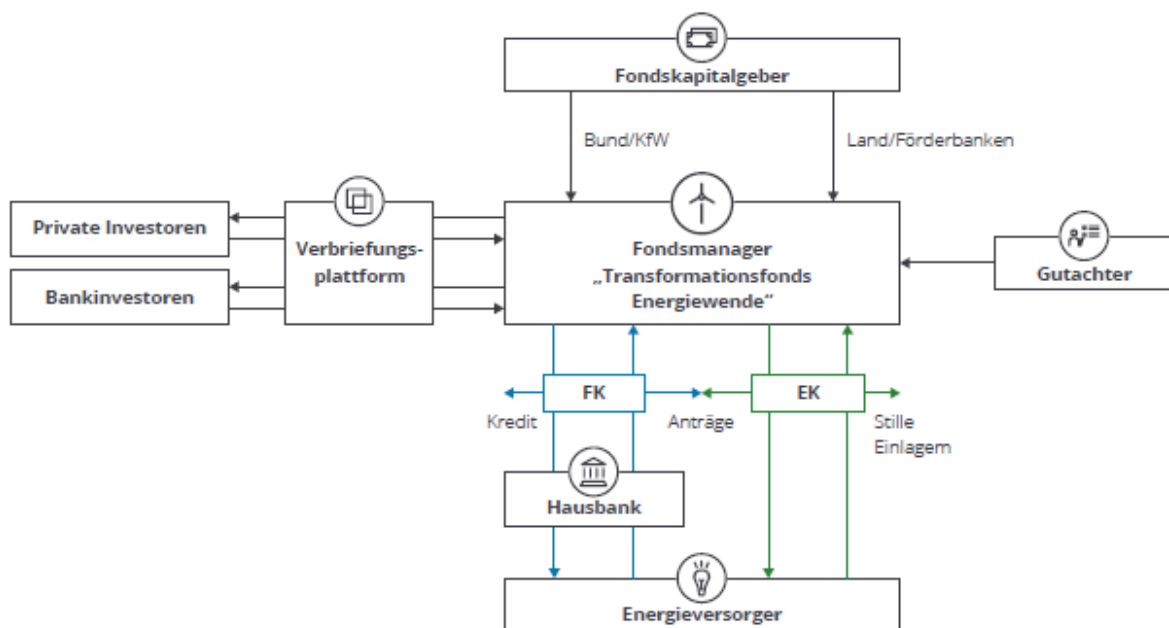

Figure 39: Energy transition fund (example) (BDEW, VKU, Deloitte, 2023)

### 11.3.9.3 Impact Investing

Impact investing involves investing in projects that generate positive social and environmental impact alongside financial returns. Geothermal projects can be attractive to impact investors, as they provide a means to generate both environmental and financial benefits.

### 11.3.9.4 Consideration of ESG factors

Environmental, social, and governance (ESG) factors are increasingly important to investors, and financial models will need to incorporate these factors into project valuation. This could include factors such as carbon emissions, community impacts, and water management.

Carbon Credits and Trading Schemes: As carbon pricing becomes more prevalent globally, geothermal projects could benefit financially from selling carbon credits, given their low-emission nature.

### 11.3.10 Decentralized Finance (DeFi)

DeFi is a rapidly evolving financial ecosystem that utilizes blockchain technology to create new financial instruments and platforms. DeFi could potentially play a role in financing geothermal projects by providing alternative financing options and improving access to capital for developers.

### 11.3.11 Energy Performance-based Contracts

This is a contractual arrangement in which a contractor designs, builds, finances, operates, and maintains a geothermal project for a predetermined period of time. The contractor is paid for the output of the geothermal project, such as the electricity it generates or the heat it provides.

As technology improves, contracts might increasingly tie payments to the performance of the geothermal plant (e.g., electricity output), aligning incentives between investors and operators.

(Philippe Dumas, 2017) mentions the following on that approach:

- *energy performance contracting can be used for geothermal projects, notably when they are included in a wider programme that includes energy efficiency improvements.*
- *particularly suitable for instance for a project to improve energy efficiency and switch the heating and cooling system of a large building. With EPC, a company (ESCO) finances the project, which is then paid back periodically according to the terms of the contract (e.g. 10% of the total every year over 10 years).*
- *Following a European Commission Guidance ([http://europa.eu/rapid/press-release\\_IP-17-3268\\_en.htm](http://europa.eu/rapid/press-release_IP-17-3268_en.htm)) issued in September 2017, public authorities are now able to use EPCs to undertake renewable or energy efficiency investments without them being accounted as debt.*
- *This is quite significant for local authorities facing debt limitation but with clear prospect to decrease their energy expenditures by investing in geothermal energy projects.*

### 11.3.12 Government and utility incentives & guaranties

#### 11.3.12.1 Fiscal investment incentives

Government and utility incentives can significantly reduce the cost and allocated financial risk of a geothermal system.

- Securing credit-financed energy transition investments through state guarantees to attract private investment:
  - o provide loan guarantees, interest rate subsidies, or other financial instruments



- strengthen financially limited energy companies
- State-induced hedging mechanism for carbon-free heating networks regarding the default risks of industrial waste heat utilization or the discovery risks of deep geothermal energy.
- The federal tax credit for renewable energy installations can offer a certain % tax credit on the cost of a geothermal system, and rebates or incentives may also be adequate options to save money on the initial investment, making geothermal more affordable.
- Reduced "Capital gain Tax for Energy Transition" or a promotion of closed energy transition funds.

A state guarantee program to secure the still increased risks in exchange-based and over-the-counter energy trading due to the war in Ukraine, countering the need for increased security deposits.

### 11.3.13 Investment by / participation of O&G companies

Technical and financial support by O&G companies especially in context of long-term technical expertise in i.e. drilling, production and operation of oil/gas fields as well as economical experience with respect to invest into small/large scale projects and the processes behind could be a beneficial approach.

Even though the sometimes bureaucratic decision processes could also hinder project development especially in the "young and still growing" geothermal playground.

An example is the approach from OMV to support EAVOR throughout their project in Germany/Geretsried with both engineering expertise and financial participation.

### 11.3.14 Crowdfunding and Community Funding / participation of citizens

There could be a rise in smaller-scale geothermal projects funded by community groups or through crowdfunding platforms. This model would democratize investments and potentially foster local support for projects.

Involving citizens voluntarily in energy transition projects can strengthen their identification with specific measures in their local area and mobilize additional capital for these projects. Citizens can also participate in the energy transition through energy communities.

- Supporting the energy transition with targeted, voluntary, and low-bureaucracy citizen projects and cooperatives.
- Balancing stable and ongoing returns with the actual yield.

### 11.3.15 International Development Funding

For developing countries, international development banks and organizations may increase their funding allocations to geothermal projects as part of global sustainability and energy access goals.

### 11.3.16 Energy-as-a-Service (EaaS)

This model, where customers pay for energy services without owning the infrastructure, could be adapted for geothermal energy, especially for direct use applications like district heating.

### 11.3.17 Integration with other Renewable Sources at the same site (Renewable Energy park)

Hybrid systems combining geothermal with other renewables (like solar or wind) could lead to more efficient and financially viable projects, possibly benefiting from diverse funding sources.

### 11.3.18 Reverse auction

A reverse auction is a competitive bidding process in which project developers bid on the right to build a geothermal project. The developer that bids the lowest price is awarded the contract. Reverse auctions can be used to lower the cost of financing geothermal projects.

### 11.3.19 Leasing of geothermal sites

Geothermal leasing involves granting a landowner or government entity the right to explore, develop, and produce geothermal resources in a specific area for a specified period. The landowner or government entity retains ownership of the land and subsurface resources while the leaseholder assumes the responsibility and costs associated with the project.

There are two main types of geothermal leases:

- Production leases: These leases grant the right to explore, develop, and produce geothermal resources.
- Non-production leases: These leases grant the right to explore for geothermal resources but do not allow for production.

### 11.3.20 Summary

- 1) *The increasing cost of capital: As the cost of capital rises, investors will demand more sophisticated financial models to assess the risks and rewards of geothermal projects.*
- 2) *The growing demand for renewable energy: The growing demand for renewable energy will put pressure on developers to find new ways to finance and develop geothermal projects. Future financial models for geothermal projects will need to adapt to changes in the energy landscape, such as the growth of renewable energy markets, the development of energy storage technologies, and the evolution of regulatory frameworks.*

Overall, future financial models for geothermal projects are likely to become more sophisticated, data-driven, and risk-aware, reflecting the growing importance of this renewable energy source.

#### 11.3.20.1 References

- General
  - [Microsoft Word - Financial Risk Management Report final \(nweurope.eu\)](#) – incl. General, France and Germany
  - Geothermal Handbook: Planning and Financing Power Generation - [FINAL Geothermal Handbook TR002-12 Reduced.pdf \(esmap.org\)](#) (2012)
  - Geothermal investment guide - [D3.4.pdf \(geoelec.eu\)](#)
  - [Geothermal Energy Market Size Share Industry Analysis \[2022-2030\] \(marketsandmarkets.com\)](#)
  - State of green - Financing the green transition – white paper 12/2023 ([State of Green publications | Green solutions and cases across sectors](#))